

PHYSICAL SETTING EARTH SCIENCE

Friday, August 17, 2012 — 12:30 to 3:30 p.m., only

Use your knowledge of Earth science to answer all questions in this examination. Before you begin this examination, you must be provided with the *2011 Edition Reference Tables for Physical Setting/Earth Science*. You will need these reference tables to answer some of the questions.

You are to answer all questions in all parts of this examination. You may use scrap paper to work out the answers to the questions, but be sure to record your answers on your answer sheet and in your answer booklet. A separate answer sheet for Part A and Part B-1 has been provided to you. Follow the instructions from the proctor for completing the student information on your answer sheet. Record your answers to the Part A and Part B-1 multiple-choice questions on this separate answer sheet. Record your answers for the questions in Part B-2 and Part C in your separate answer booklet. Be sure to fill in the heading on the front of your answer booklet.

All answers in your answer booklet should be written in pen, except for graphs and drawings, which should be done in pencil.

When you have completed the examination, you must sign the declaration printed on your separate answer sheet, indicating that you had no unlawful knowledge of the questions or answers prior to the examination and that you have neither given nor received assistance in answering any of the questions during the examination. Your answer sheet and answer booklet cannot be accepted if you fail to sign this declaration.

Notice . . .

A four-function or scientific calculator and a copy of the *2011 Edition Reference Tables for Physical Setting/Earth Science* must be available for you to use while taking this examination.

The use of any communications device is strictly prohibited when taking this examination. If you use any communications device, no matter how briefly, your examination will be invalidated and no score will be calculated for you.

DO NOT OPEN THIS EXAMINATION BOOKLET UNTIL THE SIGNAL IS GIVEN.

Part A

Answer all questions in this part.

Directions (1–35): For each statement or question, choose the word or expression that, of those given, best completes the statement or answers the question. Some questions may require the use of the *2011 Edition Reference Tables for Physical Setting/Earth Science*. Record your answers on your separate answer sheet.

1 The direction of swing of a Foucault pendulum appears to change due to Earth's

- (1) revolution (3) spherical shape
(2) rotation (4) elliptical orbit

2 Great amounts of energy are released in the core of a star as lighter elements combine and form heavier elements during the process of

- (1) compaction (3) radioactive decay
(2) condensation (4) nuclear fusion

3 Which sequence of stars is listed in order of increasing luminosity?

- (1) *Spica, Rigel, Deneb, Betelgeuse*
(2) *Polaris, Deneb, 40 Eridani B, Proxima Centauri*
(3) *Barnard's Star, Alpha Centauri, Rigel, Spica*
(4) *Procyon B, Sun, Sirius, Betelgeuse*

4 As Earth travels in its orbit, Earth's axis

- (1) remains parallel to itself at all Earth positions
(2) remains aligned with the Sun's axis
(3) is perpendicular to the Moon's axis
(4) is pointing toward the center of the Milky Way

5 To a nighttime observer on Earth, how many degrees do the stars appear to move around *Polaris* in 3 hours?

- (1) 60° (3) 3°
(2) 45° (4) 15°

6 To an observer in New York State, the duration of daylight increases continuously from

- (1) March 1 to May 1
(2) June 1 to August 1
(3) September 1 to November 1
(4) December 1 to February 1

7 The arrows in the diagram below show changes in the direction of surface winds at four lettered locations, A, B, C, and D, on Earth.

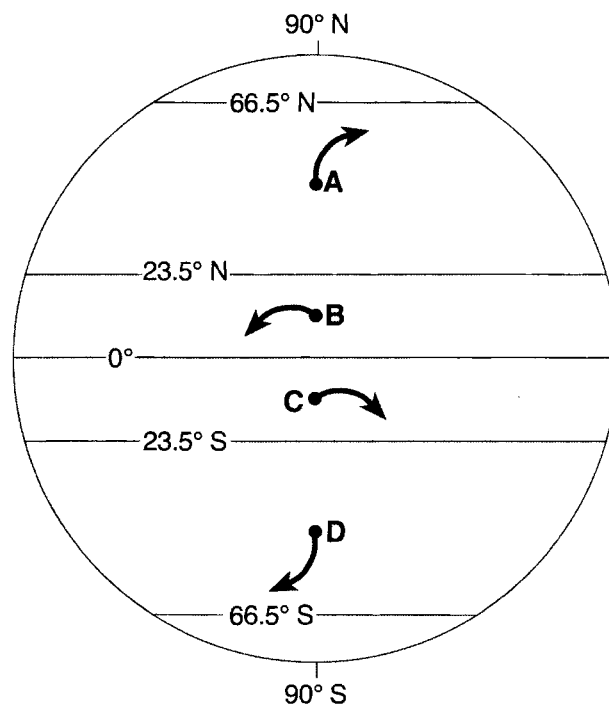

The arrow at which location correctly shows a deflection of the wind that could be due to the Coriolis effect?

- (1) A (3) C
(2) B (4) D

8 Approximately 2.2 billion years ago, which gas was first added in large amounts to Earth's atmosphere from life-forms that evolved in the oceans?

- (1) carbon dioxide (3) oxygen
(2) water vapor (4) nitrogen

9 Which weather variable generally *decreases* when wind speed is increasing, clouds are thickening, and visibility drops?

- (1) relative humidity (3) precipitation
(2) dewpoint (4) air pressure

- 10 The diagram below shows a weather instrument found at most weather stations.

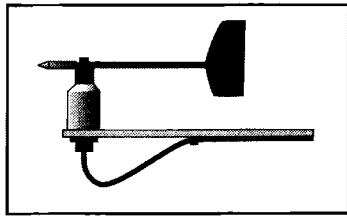

The main function of this instrument is to measure which weather variable?

- (1) wind speed (3) air pressure
 (2) wind direction (4) relative humidity
- 11 What is the approximate percent of oxygen by volume present in Earth's lower atmosphere?
 (1) 21% (3) 46%
 (2) 33% (4) 94%
- 12 Global warming is most likely occurring due to an increase in
 (1) carbon dioxide and methane gases in the atmosphere
 (2) oxygen and nitrogen gases in the atmosphere
 (3) ultraviolet radiation and x rays reflected from Earth
 (4) visible light and radio waves reflected from Earth
- 13 Which geologic event occurred in New York State at the end of the Triassic Period?
 (1) domelike uplift of the Adirondack region
 (2) formation of the Catskill delta
 (3) retreat of the last continental ice
 (4) intrusion of the Palisades sill
- 14 What is the approximate time difference between the first *P*-wave and the first *S*-wave recorded at a seismic station located 8000 kilometers from an earthquake's epicenter?
 (1) 8 minutes 40 seconds
 (2) 9 minutes 20 seconds
 (3) 11 minutes 20 seconds
 (4) 20 minutes 40 seconds

- 15 In which Earth layer does the pressure reach 3.5 million atmospheres?

- (1) crust (3) outer core
 (2) stiffer mantle (4) inner core

- 16 Which surface feature was produced by crustal movements at a transform plate boundary?

- (1) East African Rift (3) Tasman Hot Spot
 (2) Aleutian Trench (4) San Andreas Fault

- 17 The block diagram below shows part of a meandering stream. Line *XY* shows the location of a stream cross section.

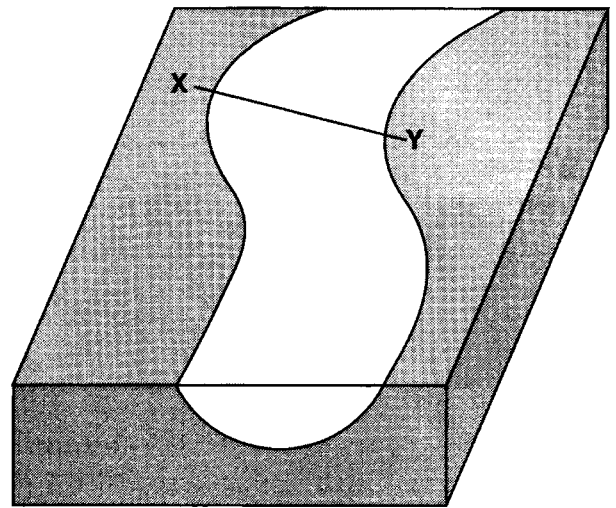

Which cross section best represents the shape of the stream channel at line *XY*?

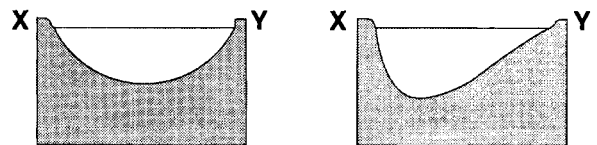

(1)

(3)

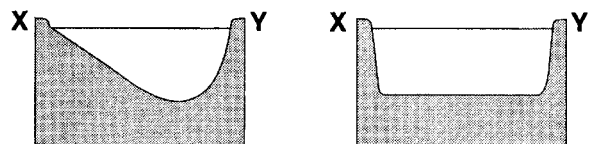

(2)

(4)

- 18 Which type of surface bedrock is most commonly found in New York State's Tug Hill Plateau region?
- (1) intrusive igneous rock layers
 - (2) extrusive igneous rock layers
 - (3) horizontal sedimentary rock layers
 - (4) faulted metamorphic rock layers

19 The cross section below shows layers of sediments deposited in a region of Wisconsin that has experienced several periods of glaciation. Descriptions of the sediments in layers A through F are included.

Layer	Sediment Description
A	Clay
B	Red mixed sediments
C	Clay, silt, and sand
D	Forest bed clay
E	Red and gray clays with lenses of silt and sand
F	Gray mixed sediments

Source: A. N. Strahler, *The Earth Sciences*, 2nd Edition, 1971 (adapted)

Which two layers of sediments were probably deposited directly by glaciers?

- (1) A and D
- (2) B and F
- (3) C and E
- (4) D and E

20 A river's current carries sediments into the ocean. Which sediment size will most likely be deposited in deeper water farthest from the shore?

- (1) pebble
- (2) sand
- (3) silt
- (4) clay

21 Which mineral would most likely become rounded at the fastest rate when tumbled along a stream bottom?

- (1) garnet
- (2) pyroxene
- (3) plagioclase feldspar
- (4) selenite gypsum

22 Mineral crystals of quartz, biotite mica, and amphibole are produced primarily by the

- (1) chemical reaction of elements in seawater
- (2) cooling and solidification of magma
- (3) deposition of sediments by a glacier
- (4) metamorphism of bituminous coal

23 Which texture best describes an igneous rock that formed deep underground?

- (1) glassy
- (2) vesicular
- (3) fine grained
- (4) coarse grained

24 A nonvesicular rock is made entirely of green 2-millimeter-diameter crystals that have a hardness of 6.5 and show fracture, but *not* cleavage. The rock is most likely

- (1) shale
- (2) phyllite
- (3) dunite
- (4) schist

25 The diagram below shows the Moon at one position in its orbit around Earth. Letter X indicates the location of an observer in New York State.

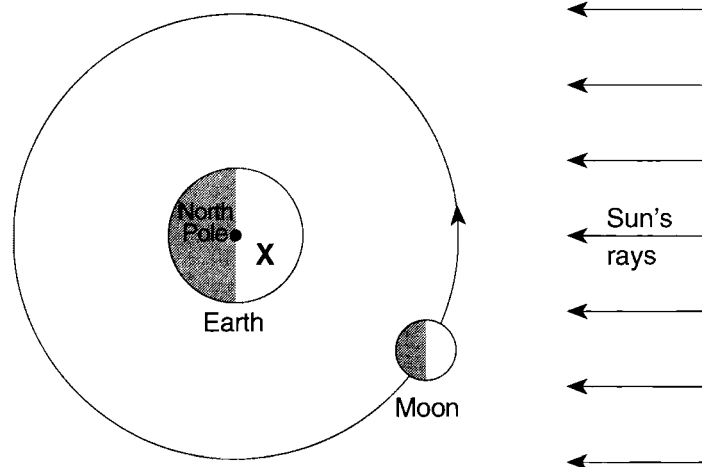

(Not drawn to scale)

Which phase of the Moon will the observer see when the Moon is at the position shown in its orbit?

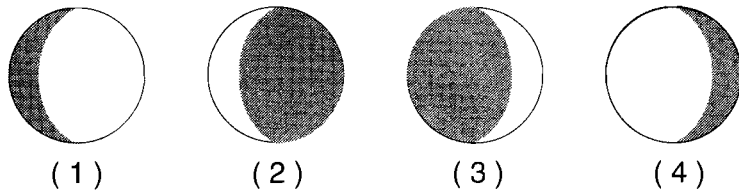

26 The photographs below show the same coastal location at two different times during the same day.



People on Beach
12:40 p.m.



People Boating
6:52 p.m.

Source: thehopewellrocks.ca (adapted)

Which statement best explains the cause for the higher water level at 6:52 p.m.?

- (1) The Moon rotates on its axis at the same rate that it revolves around Earth.
- (2) The Moon exerts a gravitational pull on a rotating Earth.
- (3) Earth's rotation causes a deflection of surface ocean currents.
- (4) Earth's tilted axis causes different amounts of insolation throughout the day.

27 Which bar graph best represents the equatorial diameters of the eight planets of our solar system?

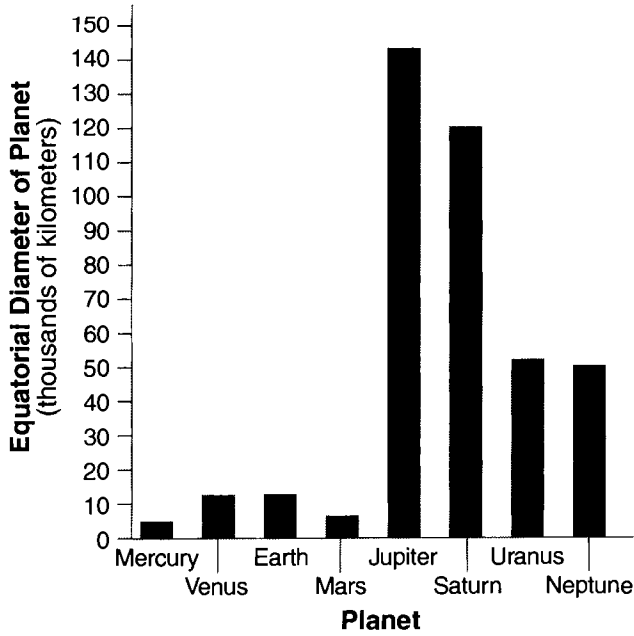

(1)

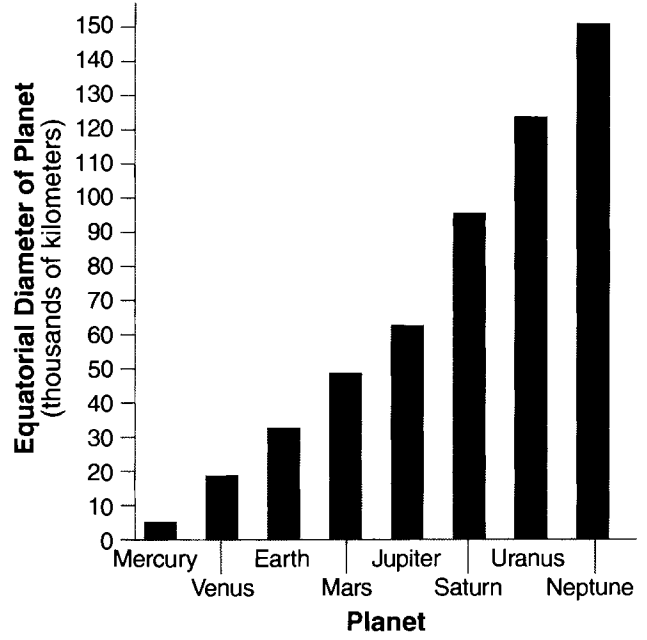

(3)

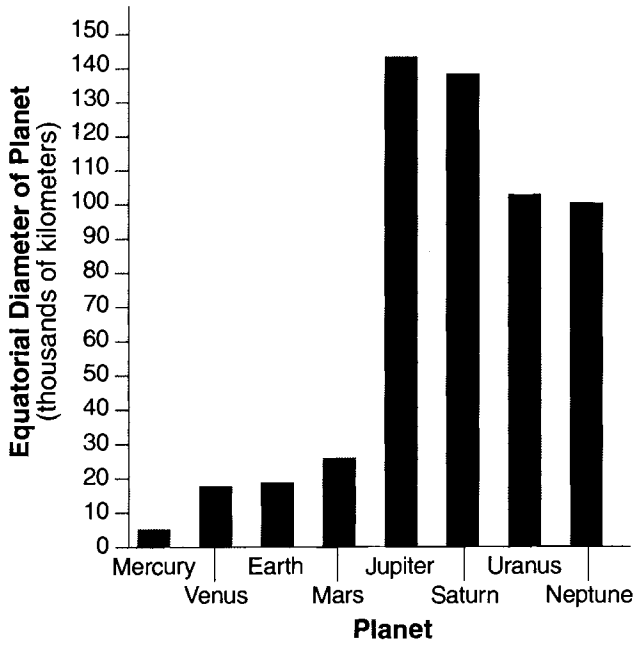

(2)

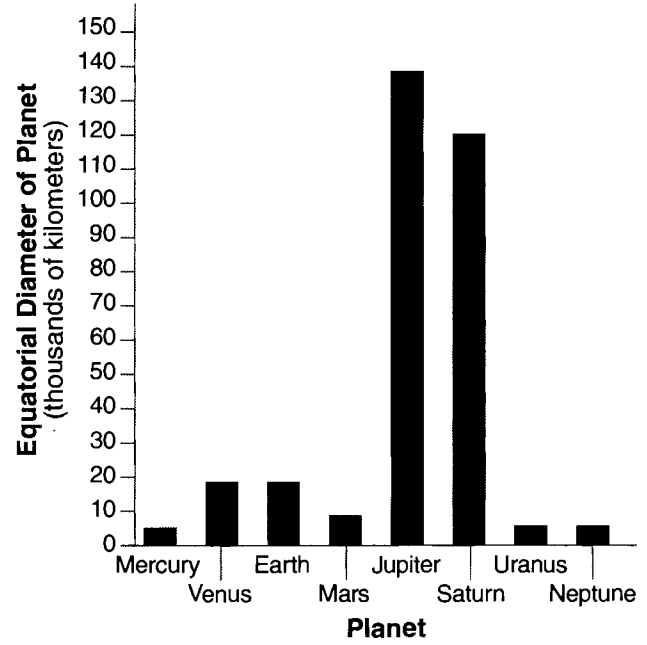

(4)

28 Which diagram represents the apparent path of the Sun on March 21 for an observer at the equator?

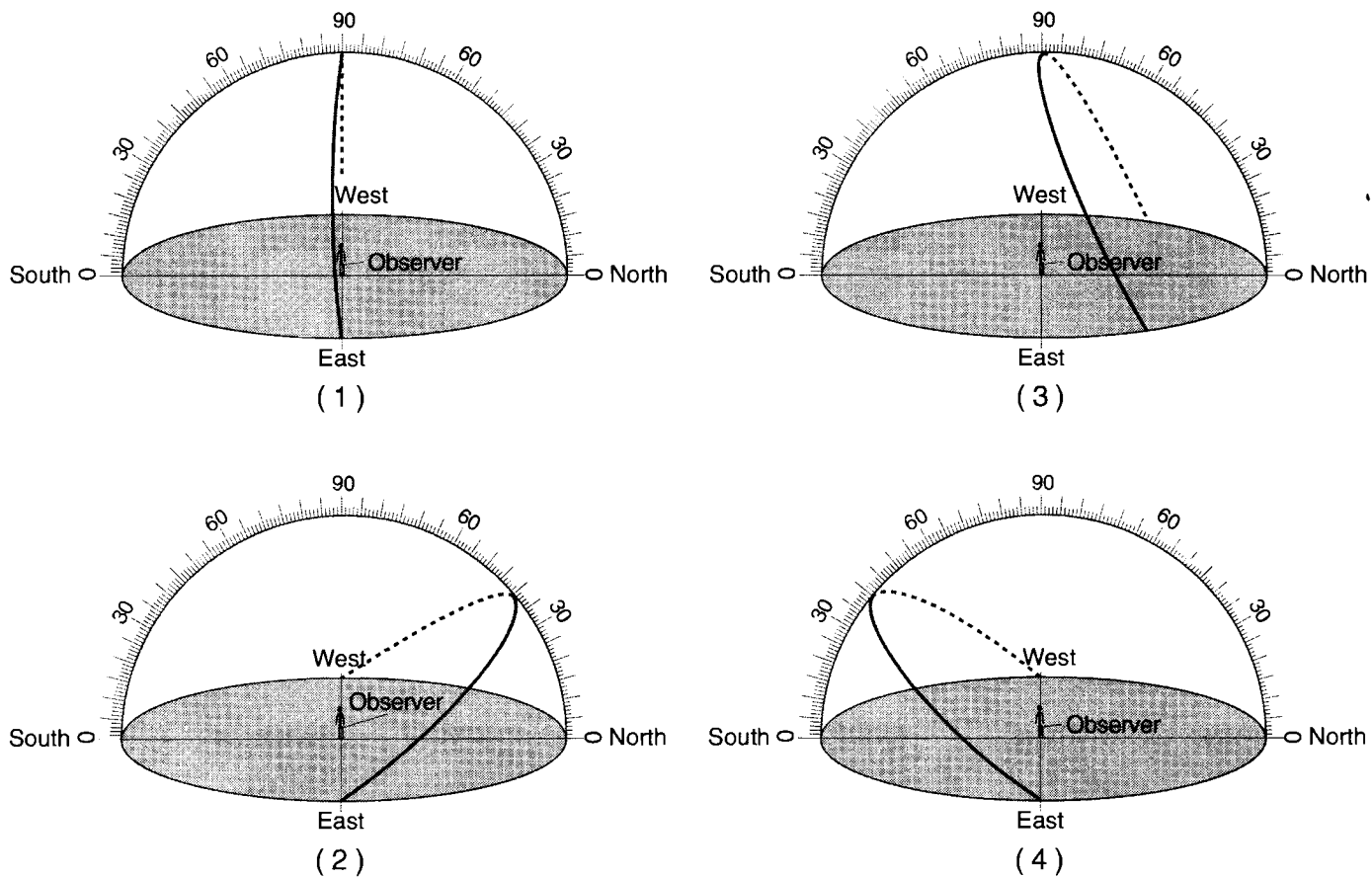

29 The arrows in the diagram below represent processes in the water cycle.

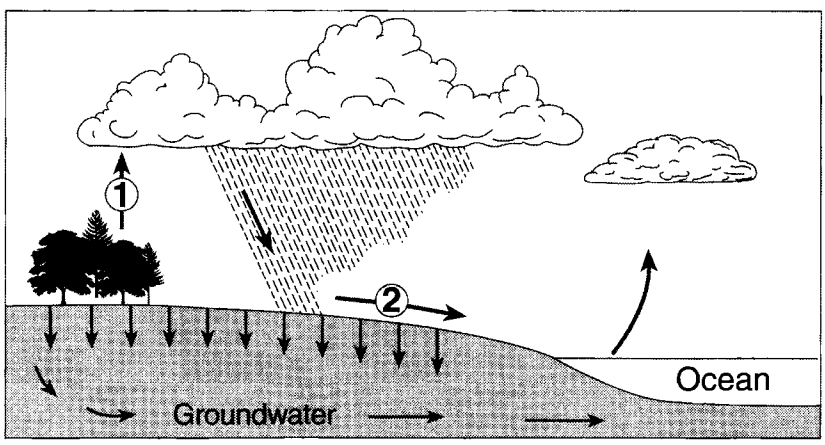

Which processes in the water cycle are identified by the numbered arrows?

- (1) Process 1 is transpiration; process 2 is runoff.
- (2) Process 1 is precipitation; process 2 is runoff.
- (3) Process 1 is condensation; process 2 is infiltration.
- (4) Process 1 is evaporation; process 2 is infiltration.

30 The diagram below represents the setup for an experiment for studying groundwater. Tubes A, B, C, and D contain equal volumes of sediments. Within each tube, the sediments are uniform in size, shape, and packing. A test for water retention was conducted by first filling each tube with water and then draining the water into beakers.

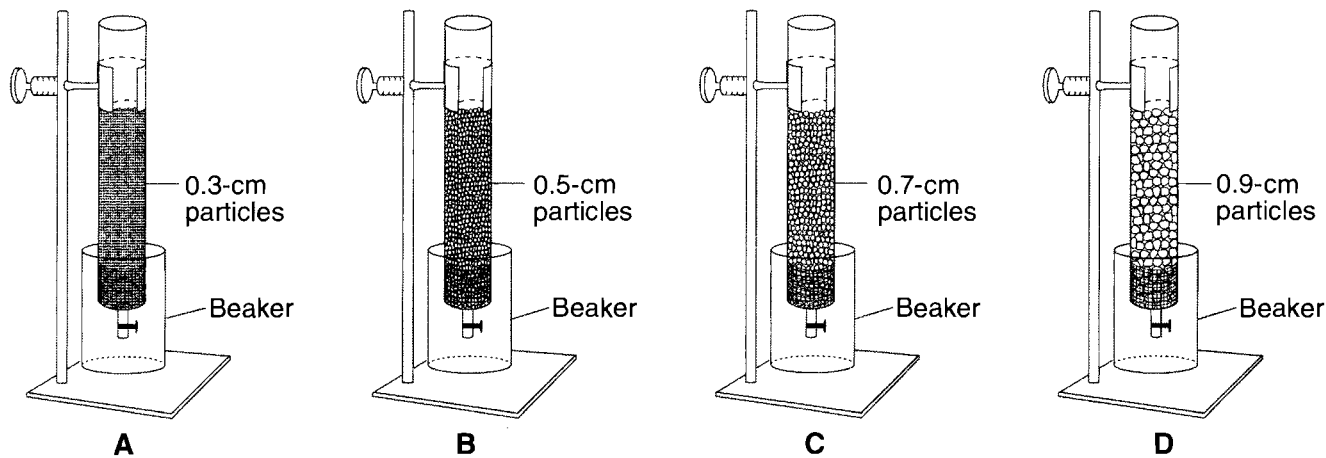

(Not drawn to scale)

Which graph represents the general relationship between the sediment size and the amount of water retained by the sediments after the tubes had drained?

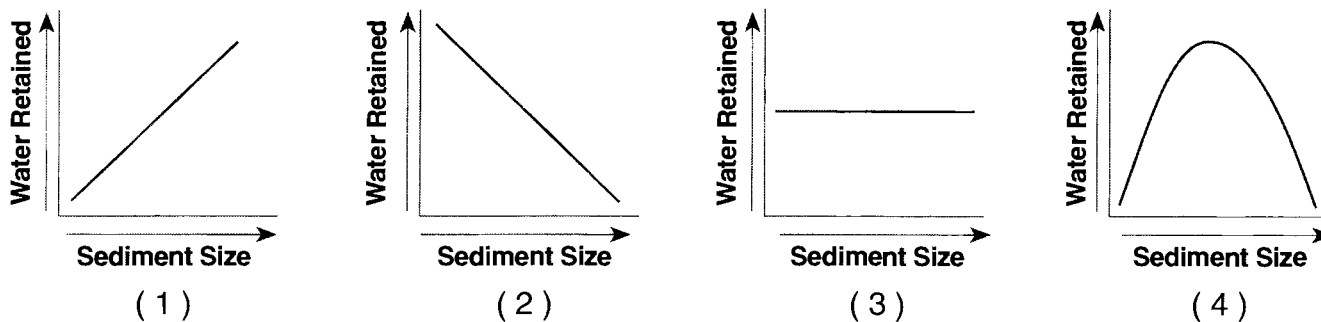

31 The geologic cross section below shows several rock units of Earth's crust. Some rock units are labeled A through E.

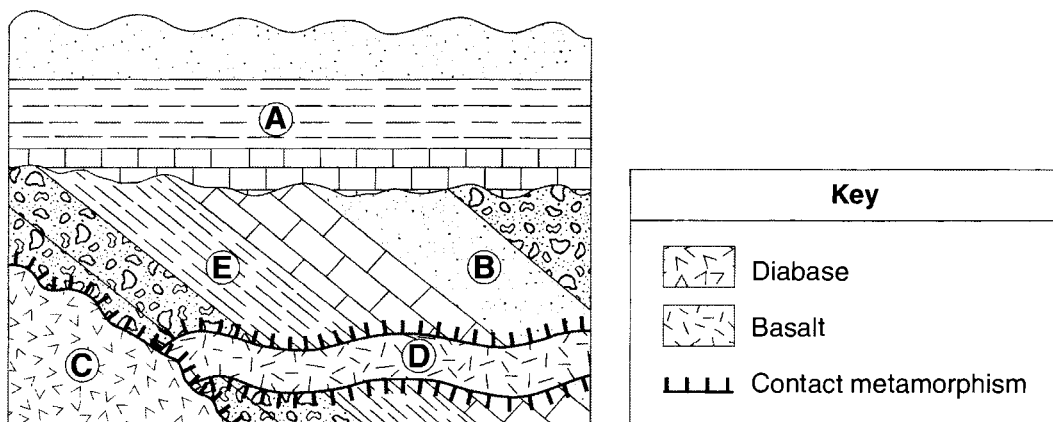

Which two rock units formed from sediments deposited in horizontal layers?

- (1) A and B
- (2) B and C
- (3) C and D
- (4) D and E

32 Weather station models for three New York State cities on the same day at the same time are shown below.

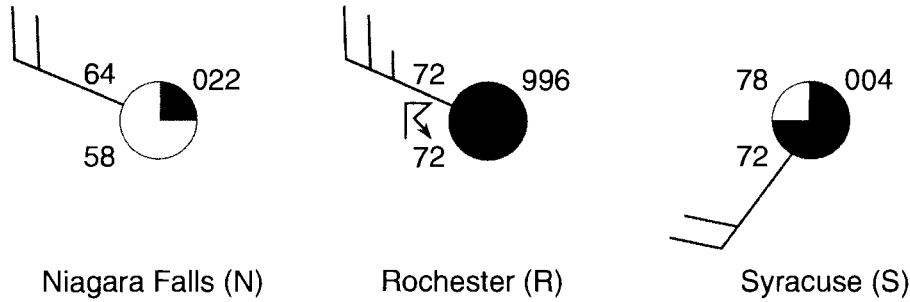

Which map shows the front that was most likely passing through Rochester at that time?

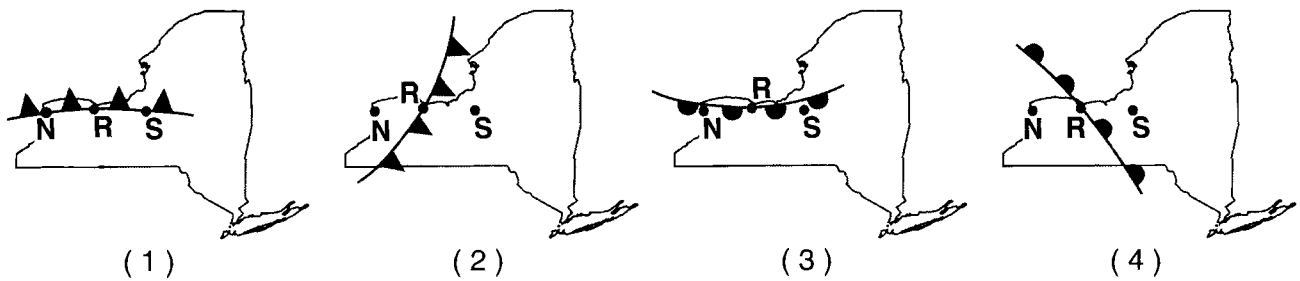

33 Arrows on the maps below show differences in the direction of winds in the region of India and the Indian Ocean during January and July. Isobar values are recorded in millibars.

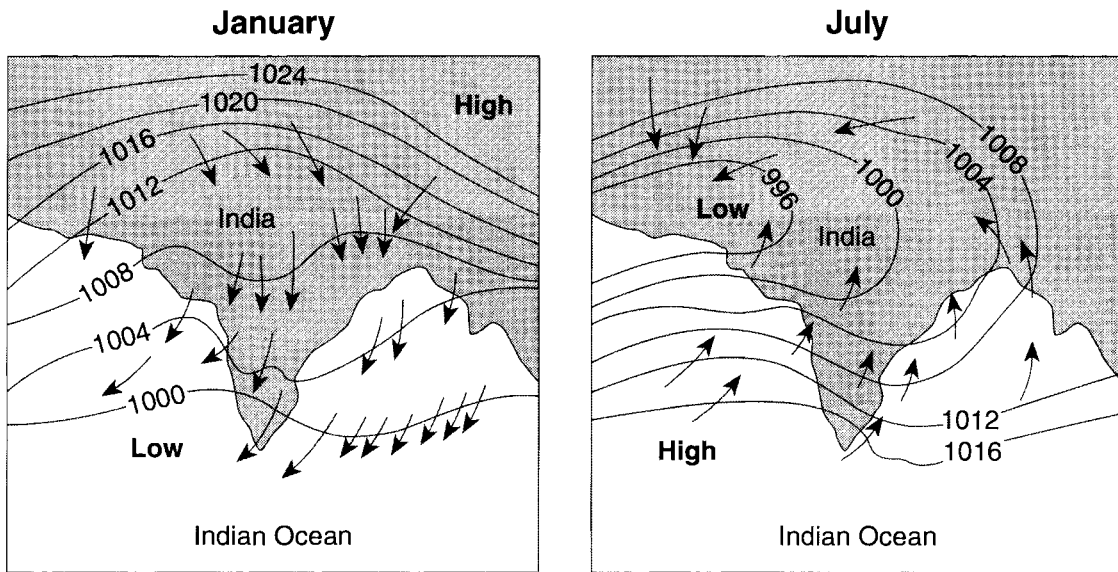

Heavy monsoon rains usually occur in India during

- (1) January, when winds blow from the land
- (2) January, when winds blow toward high pressure

- (3) July, when winds blow from the ocean
- (4) July, when winds blow toward high pressure

34 Which cross section best represents the convection currents in the mantle beneath the Peru-Chile Trench?

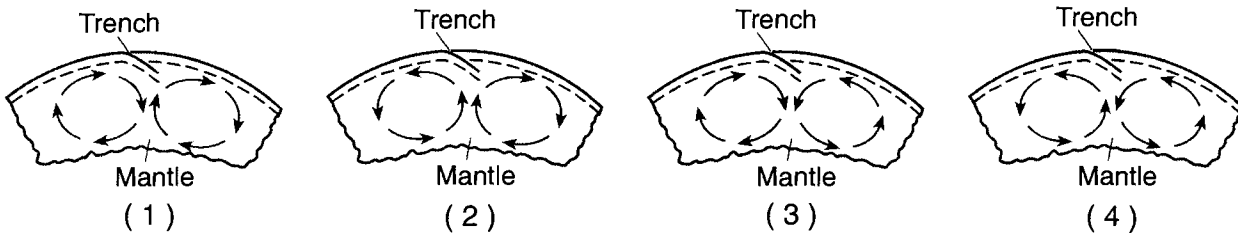

35 The sequence of block diagrams below shows stages of development of a landscape. The stages are labeled A, B, and C.

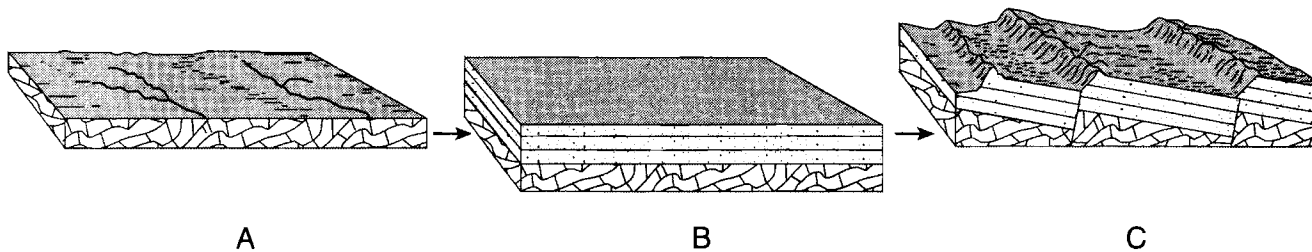

Which sequence of geologic processes best describes the events that created each stage shown?

- (1) erosion → subsidence and deposition → uplift and faulting
- (2) uplift and deposition → flooding → folding and erosion
- (3) metamorphism → erosion and deposition → volcanic eruptions
- (4) uplift and erosion → subsidence and erosion → folding

Part B-1

Answer all questions in this part.

Directions (36–50): For each statement or question, choose the word or expression that, of those given, best completes the statement or answers the question. Some questions may require the use of the 2011 Edition Reference Tables for Physical Setting/Earth Science. Record your answers on your separate answer sheet.

Base your answers to questions 36 and 37 on the data table below. The table shows the percentage of original carbon-14 remaining in three different fossils. The approximate ages of the gastropod shell and the tree wood are shown in years. The age of the human bone has been left blank.

Data Table

Fossil	Original ¹⁴C Remaining (%)	Approximate Age (y)
gastropod shell	50	5,700
tree wood	25	11,400
human bone	12.5	

36 What is the approximate age of the human bone fossil?

- (1) 5,700 y
- (2) 17,100 y
- (3) 22,800 y
- (4) 39,900 y

37 During which geologic period did all three fossils form?

- (1) Quaternary
 - (2) Neogene
 - (3) Paleogene
 - (4) Permian
-

Base your answers to questions 38 through 41 on the passage and map below. The map shows sections of the Atlantic Ocean, the Caribbean Sea, and the Gulf of Mexico.

Shipwreck

In 1641, the crew of the ship *Concepcion* used the Sun and stars for navigation. The crew thought that the ship was just north of Puerto Rico, but ocean currents had carried them off course. The ship hit a coral reef and sank off the coast of the Dominican Republic. The **X** on the map marks the location of the sunken ship.

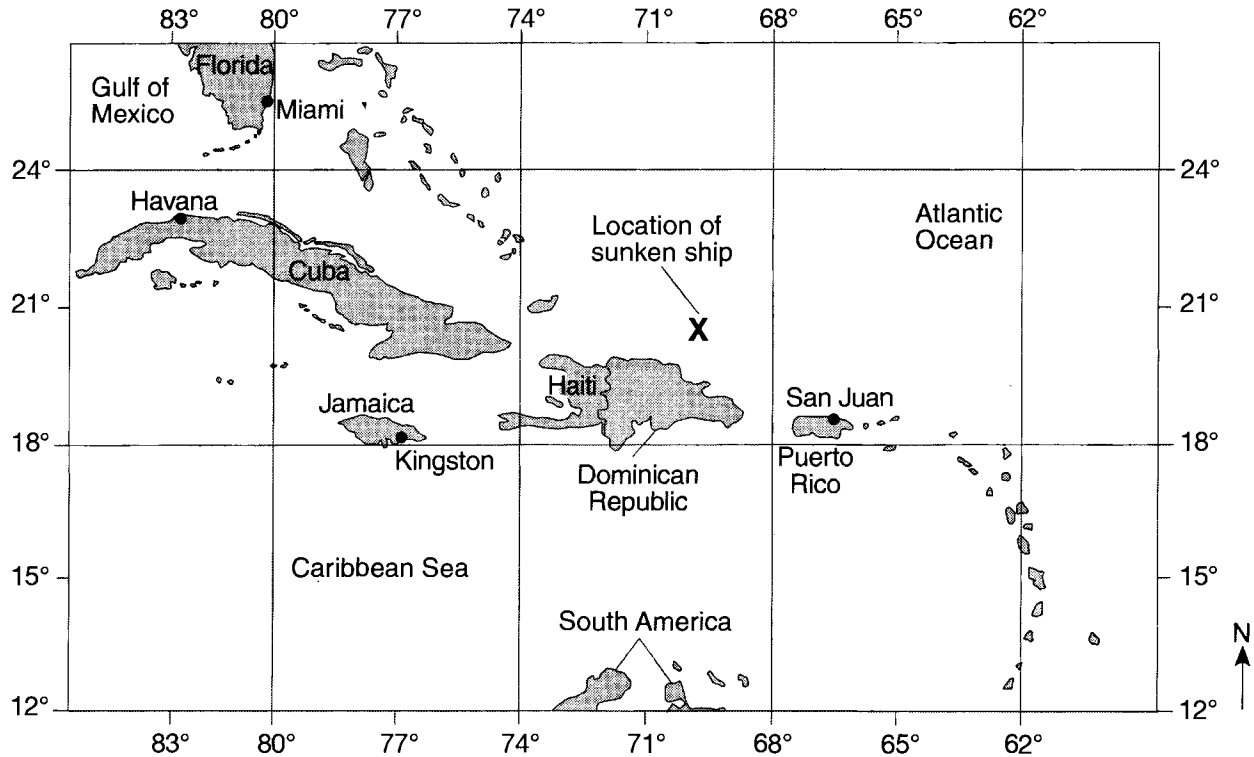

38 The *Concepcion* was carried off course to the northwest by an ocean current flowing from the

- | | |
|-------------------------|------------------------------|
| (1) Florida Current | (3) North Atlantic Current |
| (2) Gulf Stream Current | (4) North Equatorial Current |

39 What is the approximate latitude and longitude of the sunken ship?

- | | |
|-------------------|-------------------|
| (1) 20.5° N 70° E | (3) 20.5° S 70° E |
| (2) 20.5° N 70° W | (4) 20.5° S 70° W |

40 At which map location does *Polaris* appear the highest in the nighttime sky?

- | | |
|-----------------------|---------------------------|
| (1) Miami, Florida | (3) Havana, Cuba |
| (2) Kingston, Jamaica | (4) San Juan, Puerto Rico |

41 On which tectonic plate is Puerto Rico located?

- | | |
|--------------------------|---------------------|
| (1) North American Plate | (3) Caribbean Plate |
| (2) South American Plate | (4) Cocos Plate |

Base your answers to questions 42 through 44 on the cross sections below, which represent a particular location of the channel of the San Juan River in Utah. Changes in river discharge (Q), in cubic meters per second, and sediment deposits before, during, and after a flood are shown.

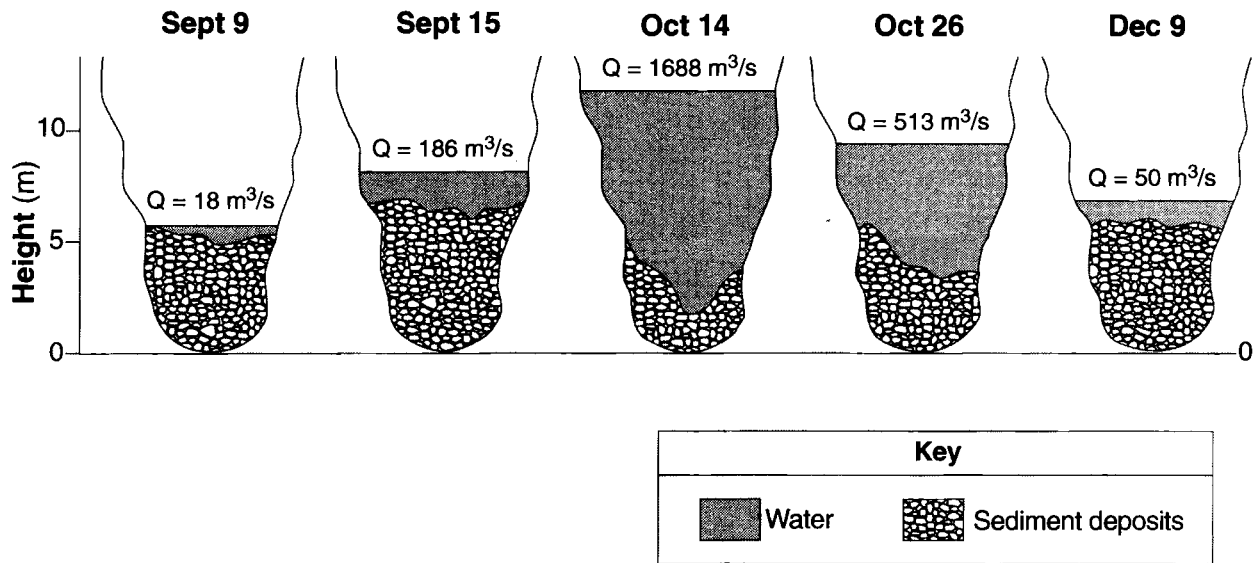

- 42 During the time from September 9 to October 14, the thickness of the sediment deposits at the bottom of the San Juan River's channel
- (1) decreased, only
 (2) increased, only
 (3) decreased and then increased
 (4) increased and then decreased
- 43 On October 14, during the flood, the discharge of the San Juan River changed dramatically. The change in the river's discharge at this location was related to an increase in the river's
- (1) velocity
 (2) gradient
 (3) channel length
 (4) sediment deposits
- 44 If the greatest velocity of the San Juan River on December 9 was 10 centimeters per second, what was the approximate diameter of the largest particles that the river could have carried?
- (1) 1.0 cm
 (2) 2.0 cm
 (3) 10.0 cm
 (4) 0.2 cm

Base your answers to questions 45 through 48 on the map below, which shows the position of the jet stream relative to two air masses and a low-pressure center (L) over the United States.

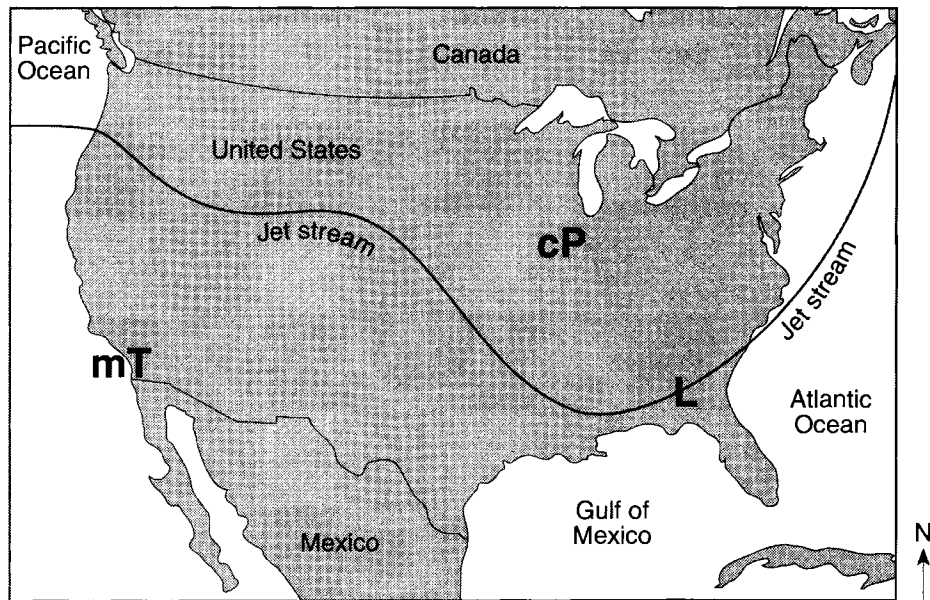

- 45 In which layer of the atmosphere is this jet stream located?
- (1) thermosphere
 - (2) mesosphere
 - (3) stratosphere
 - (4) troposphere
- 46 What is the difference in the air temperature and humidity between the cP and mT air masses?
- (1) The cP air mass is warmer and less humid.
 - (2) The cP air mass is colder and more humid.
 - (3) The mT air mass is warmer and more humid.
 - (4) The mT air mass is colder and less humid.
- 47 What is the general movement of the surface winds around the center of this low-pressure area?
- (1) counterclockwise and outward
 - (2) counterclockwise and inward
 - (3) clockwise and outward
 - (4) clockwise and inward
- 48 Assuming the low-pressure center (L) follows a typical storm track, it will move
- (1) into the mT air mass to the west
 - (2) into the cP air mass to the northwest
 - (3) along the path of the jet stream to the northeast
 - (4) along the path of the jet stream to the southwest
-

Base your answers to questions 49 and 50 on the passage and photograph below.

Dinosaur Tracks Revealed After Years of Dry Weather

By April 2005, the surface of Lake Powell, a human-made lake in Utah and Arizona, had fallen 145 feet below its highest level. This revealed many traces of ancient life that had not been observed since this area had been covered with water. Among these traces, discovered in sandstone bedrock, were many dinosaur tracks, ranging in age between 170 and 200 million years old.

Dinosaur Track on Shoreline of Lake Powell



Source: Andre Delgalvis, *Arizona Highways*,
February 2006

49 The events listed below led to the formation and exposure of these dinosaur tracks.

- A. Rock layers above the dinosaur tracks are eroded.
- B. Tracks are made in loose sand by dinosaurs.
- C. Sediments are compressed and cemented.
- D. Sedimentation buries tracks.
- E. The water level of Lake Powell drops.

What is the correct sequence of the events listed above that led to the formation and exposure of the dinosaur tracks in the surface bedrock along the shoreline of Lake Powell?

- (1) $B \rightarrow C \rightarrow A \rightarrow E \rightarrow D$
- (2) $B \rightarrow D \rightarrow C \rightarrow A \rightarrow E$
- (3) $E \rightarrow D \rightarrow A \rightarrow B \rightarrow C$
- (4) $E \rightarrow C \rightarrow B \rightarrow D \rightarrow A$

50 Which conditions before April 2005 in the Lake Powell region most likely produced the *decrease* in the water level of Lake Powell?

- (1) Runoff exceeded precipitation.
- (2) Precipitation exceeded runoff.
- (3) Evaporation exceeded precipitation.
- (4) Precipitation exceeded evaporation.

Part B-2

Answer all questions in this part.

Directions (51–65): Record your answers in the spaces provided in your answer booklet. Some questions may require the use of the *2011 Edition Reference Tables for Physical Setting/Earth Science*.

Base your answers to questions 51 through 53 on the map below, which shows a portion of New York State and Canada. The arrows represent the direction of the wind blowing over Lake Ontario for several days early one winter.

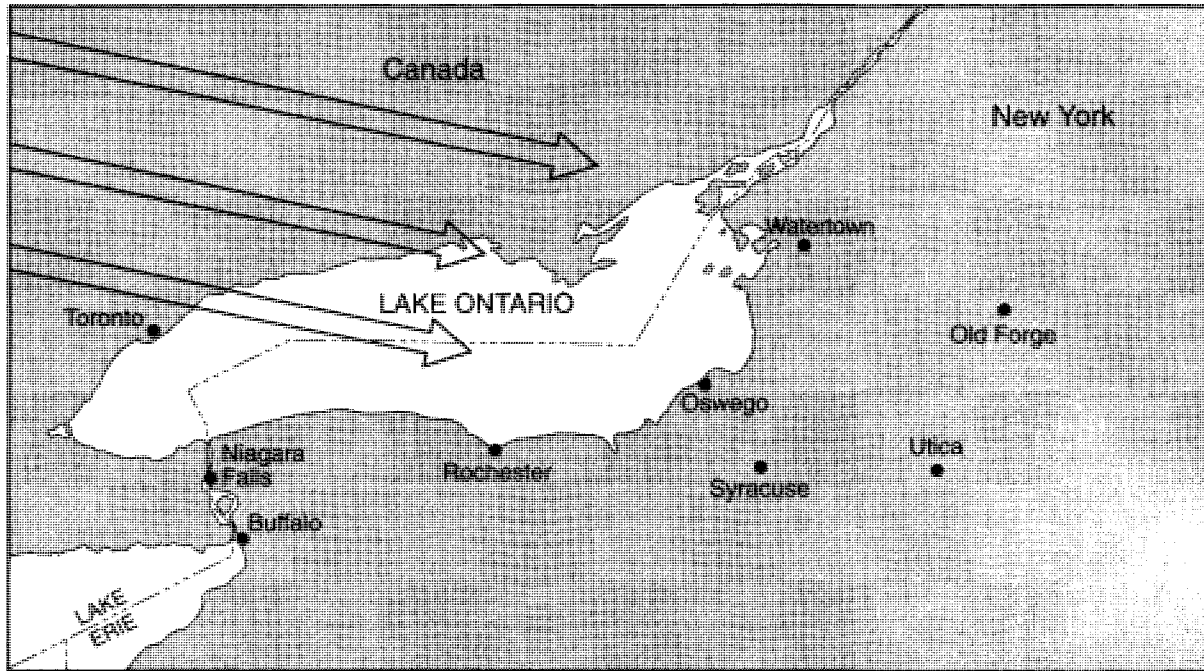

- 51 Explain why Oswego, New York, usually gets more snow than Toronto, Canada, when the wind is blowing in the direction shown on the map. [1]
- 52 Compared to the average winter air temperature in Watertown, New York, explain why the average winter air temperature in Old Forge, New York, is colder. [1]
- 53 Explain why the surface of Lake Erie freezes much later in the winter than the surrounding land surfaces. [1]
-

Base your answers to questions 54 through 57 on the passage below.

Meteorite Composition

Meteors that strike Earth's surface are called meteorites. Analysis of meteorite composition has provided scientists with information regarding the formation of Earth and our solar system, and possibly the development and evolution of life on Earth.

Two types of meteorites are iron meteorites and chondrites. Iron meteorites consist mostly of iron and nickel, and are inferred to be from core materials of early planetary bodies in our solar system. More than 60% of meteorites studied have been identified as chondrites. Chondrites are made of millimeter-sized spheres of olivine and pyroxene crystals embedded in a mass of mineral and metal grains. The chondrites are thought to represent fragments of the earliest solid materials in our solar system. One type of chondrite, the carbonaceous chondrite, contains water, organic compounds, and minerals that represent the chemical composition necessary for life to form.

- 54 Identify the type of meteorite that is inferred to have a composition similar to the composition of Earth's core. [1]
- 55 Identify *two* elements that can be found in *both* olivine and pyroxene. [1]
- 56 What is the estimated age, in years, of Earth and our solar system? [1]
- 57 Explain why there is little evidence of meteorite impact craters on Earth. [1]
-

Base your answers to questions 58 through 61 on the generalized map below, which shows a portion of the Atlantic Ocean floor located between South America and Africa. Isolines show the approximate age, in million years, of the ocean-floor bedrock on each side of the Mid-Atlantic Ridge. Points A, B, and X represent locations on the ocean floor.

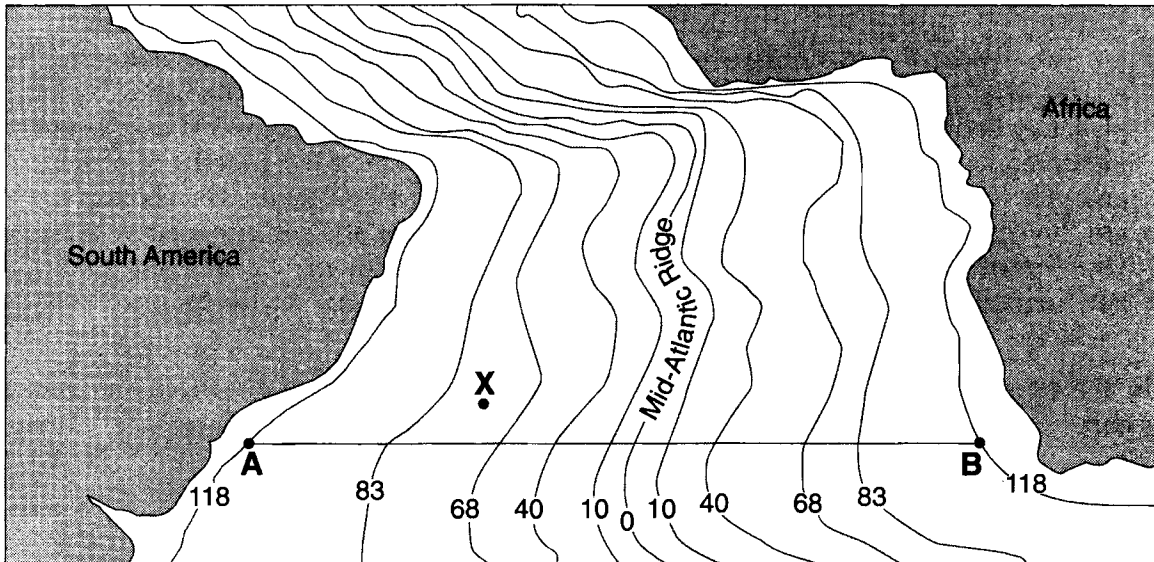

- 58 On the grid in your answer booklet, construct a line graph of bedrock age by plotting the age of the bedrock shown by each isoline that crosses line AB. Points A and B are plotted on the grid. Connect the plots from A to B with a line. [1]
- 59 Estimate the age of the ocean-floor bedrock at point X. [1]
- 60 Explain why the age of the ocean-floor bedrock increases as the distance from the Mid-Atlantic Ridge increases. [1]
- 61 The Mid-Atlantic Ridge separates pairs of crustal plates, such as the South American Plate and the African Plate. Identify one other pair of crustal plates separated by the Mid-Atlantic Ridge. [1]
-

Base your answers to questions 62 through 65 on the topographic map in your answer booklet. Letters *A* through *D* represent locations on the map. Elevations are measured in feet. Dashed lines represent trails.

62 On the map *in your answer booklet*, place an **X** on the trail between *A* and *B* so the center of the **X** indicates where the slope is steepest. [1]

63 On the map *in your answer booklet*, first draw an arrow on the stream to show the direction in which the stream is flowing. Then state *one* piece of evidence shown on the map that supports the direction of the arrow you drew on the stream. [1]

64 Identify the contour interval used on this map. [1]

65 How long will it take a person to hike along the trail from point *C* to point *D* at a rate of 3 miles per hour? [1]

Part C

Answer all questions in this part.

Directions (66–85): Record your answers in the spaces provided in your answer booklet. Some questions may require the use of the *2011 Edition Reference Tables for Physical Setting/Earth Science*.

Base your answers to questions 66 through 68 on the bar graph below and on the data table in your answer booklet. The bar graph shows the number of partial lunar eclipses that occurred during each of the last nine centuries (100-year intervals) on Earth. A partial lunar eclipse occurs when only part of the Moon is within the darkest part of Earth's shadow. The data table in your answer booklet shows the number of total lunar eclipses that occurred during the same nine centuries. A total lunar eclipse occurs when the entire Moon is completely within the darkest part of Earth's shadow.

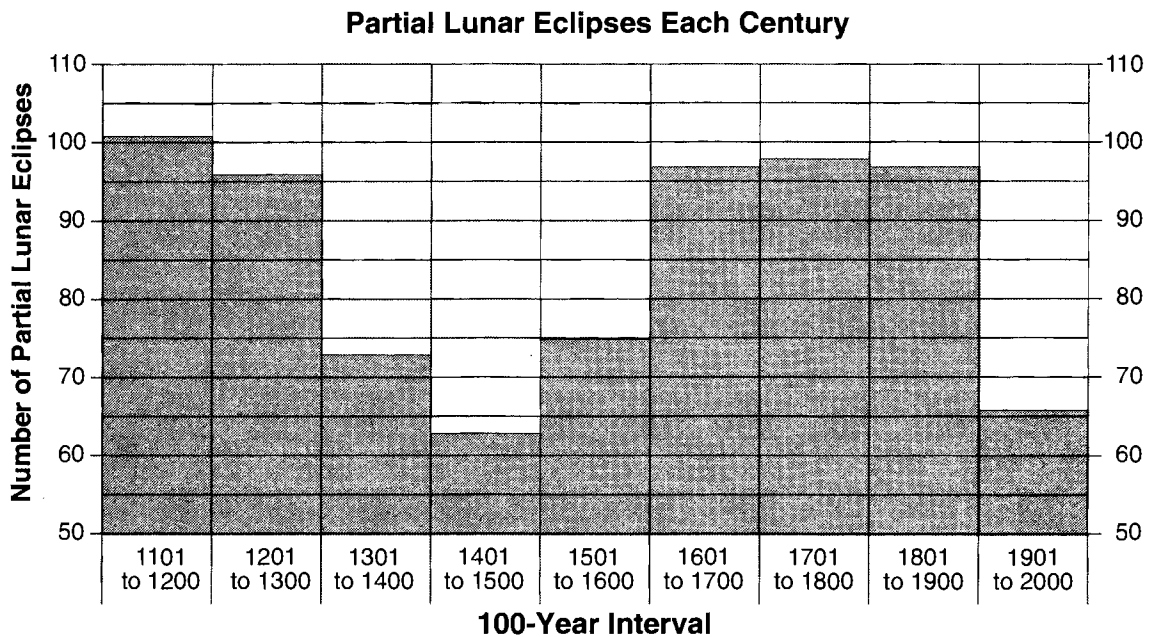

- 66 On the grid in your answer booklet, construct a bar graph of the number of total lunar eclipses for each 100-year interval listed on the data table in your answer booklet. [1]
- 67 State the relationship between the number of partial lunar eclipses per century and the number of total lunar eclipses per century. [1]
- 68 On the diagram in your answer booklet, draw an **X** so the center of the **X** indicates the position of Earth during a lunar eclipse. [1]
-

Base your answers to questions 69 through 74 on the geologic cross section below, which shows rock units 1 through 7 that have *not* been overturned. Some of the rock units contain New York State index fossils. An unconformity exists between rock units 5 and 6.

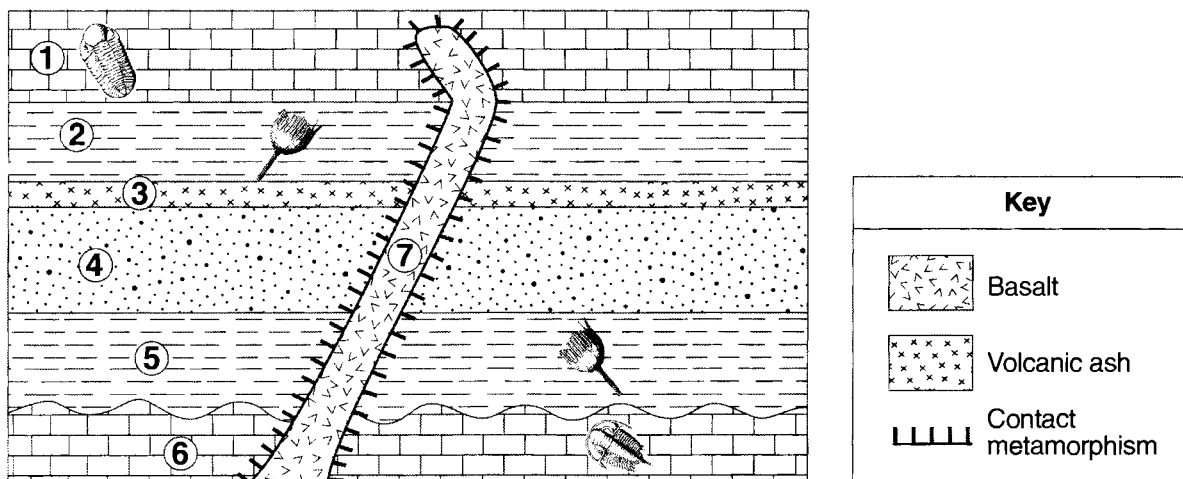

- 69 State the grain size of the sediment that was deposited to form rock unit 2. [1]
- 70 Identify *two* processes that produced the basalt. [1]
- 71 What evidence shown in the cross section indicates that the basalt rock unit is the youngest rock unit? [1]
- 72 Bedrock from which entire geologic time period is missing between rock units 5 and 6? [1]
- 73 Identify *one* metamorphic rock that could have been formed by the contact metamorphism within rock unit 1. [1]
- 74 Describe *one* characteristic of volcanic ash layers and index fossils that makes *both* of them good geologic time markers. [1]
-

Base your answers to questions 75 through 78 on the map in your answer booklet, which shows surface air temperatures, in degrees Fahrenheit, for a portion of the United States. These temperatures were recorded at noontime on the same winter day. Two coastal cities are labeled: Atlantic City, New Jersey, and Miami, Florida. Other selected locations are labeled A, B, and C.

75 On the map *in your answer booklet*, draw the 60°F isotherm from location A to the western edge of the map. [1]

76 Calculate the temperature gradient between locations B and C in °F per mile. [1]

77 Explain why the noontime winter air temperatures in Miami, Florida, are usually higher than the noontime winter air temperatures in Atlantic City, New Jersey. [1]

78 A frontal boundary exists between locations B and C. Identify *one* process that causes clouds to form in the moist air rising along this frontal boundary. [1]

Base your answers to questions 79 and 80 on the climate graph below, which shows the average monthly precipitation and average monthly air temperatures at city X. City X is located near a mountain range in the Southern Hemisphere.

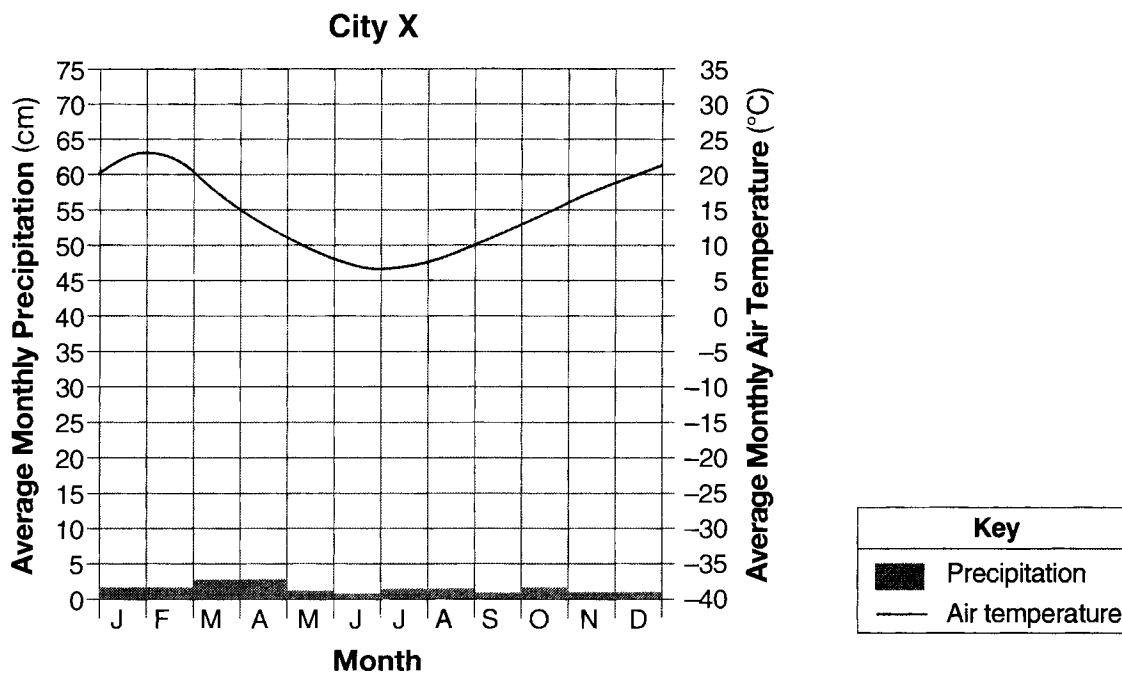

79 What evidence shown on the graph indicates that city X is located in the Southern Hemisphere? [1]

80 *In your answer booklet*, state whether the climate of city X is dry or wet. Then, on the cross section *in your answer booklet*, place an **X** on Earth's surface to indicate the most likely location of city X. [1]

Base your answers to questions 81 through 85 on the diagram in your answer booklet. The diagram shows Earth revolving around the Sun. Letters *A*, *B*, *C*, and *D* represent Earth's location in its orbit on the first day of the four seasons. Aphelion (farthest distance from the Sun) and perihelion (closest distance to the Sun) are labeled to show the approximate times when they occur in Earth's orbit.

- 81 On the diagram *in your answer booklet*, draw a line through Earth at location *A* to represent Earth's tilted axis on the first day of summer in the Northern Hemisphere. Label the North Pole end of the axis. [1]
- 82 On the diagram *in your answer booklet*, draw an arrow on Earth at location *D* to show the direction of Earth's rotation. Extend the arrow from one side of Earth to the other side of Earth. [1]
- 83 Approximately how many days does it take Earth to travel from location *B* to location *C*? [1]
- 84 Explain why the gravitational attraction between the Sun and Earth *decreases* as Earth travels from location *D* to location *A*. [1]
- 85 Explain why an observer in New York State sees some different constellations in the night sky when Earth is at location *A* compared to when Earth is at location *C*. [1]
-

FOR TEACHERS ONLY

The University of the State of New York
REGENTS HIGH SCHOOL EXAMINATION

PS-ES PHYSICAL SETTING/EARTH SCIENCE

Friday, August 17, 2012 — 12:30 to 3:30 p.m., only

SCORING KEY AND RATING GUIDE

Directions to the Teacher:

Refer to the directions on page 2 before rating student papers.

Updated information regarding the rating of this examination may be posted on the New York State Education Department's web site during the rating period. Check this web site at: <http://www.p12.nysed.gov/apda/> and select the link "Scoring Information" for any recently posted information regarding this examination. This site should be checked before the rating process for this examination begins and several times throughout the Regents Examination period.

Part A and Part B-1

Allow 1 credit for each correct response.

Part A

1 2	10 2	19 2	28 1
2 4	11 1	20 4	29 1
3 4	12 1	21 4	30 2
4 1	13 4	22 2	31 1
5 2	14 2	23 4	32 2
6 1	15 4	24 3	33 3
7 1	16 4	25 2	34 3
8 3	17 3	26 2	35 1
9 4	18 3	27 1	

Part B-1

36 2	40 1	44 4	48 3
37 1	41 3	45 4	49 2
38 4	42 4	46 3	50 3
39 2	43 1	47 2	

Directions to the Teacher

Follow the procedures below for scoring student answer papers for the Regents Examination in Physical Setting/Earth Science. Additional information about scoring is provided in the publication *Information Booklet for Scoring Regents Examinations in the Sciences*.

Do *not* attempt to correct the student's work by making insertions or changes of any kind.

Allow 1 credit for each correct response.

At least two science teachers must participate in the scoring of the Part B–2 and Part C open-ended questions on a student's paper. Each of these teachers should be responsible for scoring a selected number of the open-ended questions on each answer paper. No one teacher is to score more than approximately one-half of the open-ended questions on a student's answer paper.

Students' responses must be scored strictly according to the Scoring Key and Rating Guide. For open-ended questions, credit may be allowed for responses other than those given in the rating guide if the response is a scientifically accurate answer to the question and demonstrates adequate knowledge as indicated by the examples in the rating guide. On the student's separate answer sheet, for each question, record the number of credits earned and the teacher's assigned rater/scorer letter.

Fractional credit is *not* allowed. Only whole-number credit may be given for a response. Units need not be given when the wording of the questions allows such omissions.

For hand scoring, raters should enter the scores earned in the appropriate boxes printed on the separate answer sheet. Next, the rater should add these scores and enter the total in the space provided. The student's score for the Earth Science Performance Test should be recorded in the space provided. Then the student's raw scores on the written test and the performance test should be converted to a scale score by using the conversion chart that will be posted on the Department's web site at: <http://www.p12.nysed.gov/apda/> on Friday, August 17, 2012. The student's scale score should be entered in the box labeled "Scale Score" on the student's answer sheet. The scale score is the student's final examination score.

Schools are not permitted to rescore any of the open-ended questions on this exam after each question has been rated once, regardless of the final exam score. Schools are required to ensure that the raw scores have been added correctly and that the resulting scale score has been determined accurately.

Because scale scores corresponding to raw scores in the conversion chart may change from one administration to another, it is crucial that for each administration, the conversion chart provided for that administration be used to determine the student's final score.

Part B–2

Allow a maximum of 15 credits for this part.

- 51** [1] Allow 1 credit. Acceptable responses include, but are not limited to:
- The air travels over Lake Ontario toward Oswego, picking up moisture that results in more snow.
 - The air over Toronto contains less moisture.
 - Lake-effect storms occur on the eastern side of the lake when the wind is blowing in the direction shown.
- 52** [1] Allow 1 credit. Acceptable responses include, but are not limited to:
- Old Forge is located in the mountains.
 - Higher elevations have colder temperatures.
 - Watertown is closer to a large body of water that moderates its temperature.
- 53** [1] Allow 1 credit. Acceptable responses include, but are not limited to:
- Water has a higher specific heat than land.
 - Water takes a longer time to cool than land.
 - Land surfaces cool faster.
- 54** [1] Allow 1 credit for iron meteorite(s) *or* iron.
- 55** [1] Allow 1 credit if *both* elements are correct. Acceptable responses include, but are not limited to:
- iron/Fe
 - magnesium/Mg
 - silicon/Si
 - oxygen/O
- 56** [1] Allow 1 credit. Acceptable responses include, but are not limited to:
- 4,600 million y
 - 4.6 billion y
 - 4,600,000,000 y
- 57** [1] Allow 1 credit. Acceptable responses include, but are not limited to:
- Weathering and erosion on Earth’s surface have erased many craters.
 - Most meteors are very small and burn up in Earth’s atmosphere.
 - Most of Earth’s surface is ocean, where sediments cover impact craters.
 - Crustal plate movement has destroyed the evidence.

- 58 [1] Allow 1 credit if *all nine* ages are correctly plotted within the rectangles shown below and are connected with a line from A to B that passes within the rectangles.

Note: It is recommended that an overlay with the same scale as the student answer booklet be used to ensure reliability in rating.

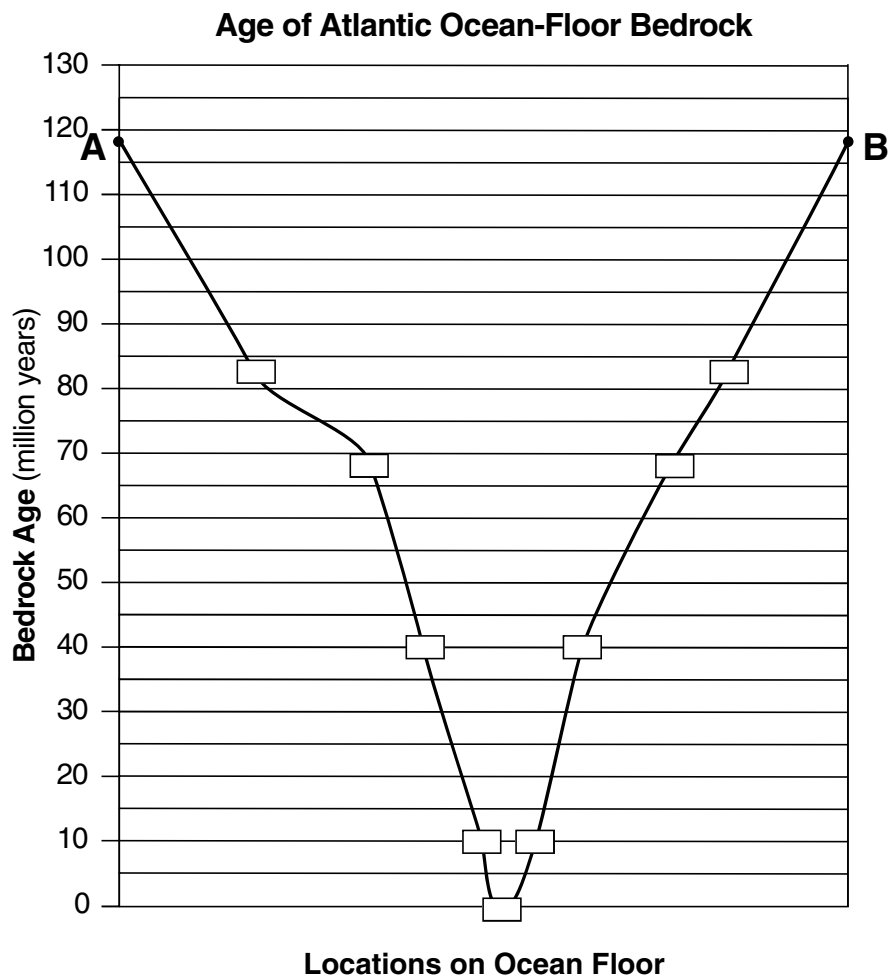

- 59 [1] Allow 1 credit for any value greater than 68 million years *and* less than 83 million years.

- 60 [1] Allow 1 credit. Acceptable responses include, but are not limited to:

- Plates are diverging at the Mid-Atlantic Ridge where new seafloor is forming.
- The boundary between the South American Plate and the African Plate is a spreading center.
- New oceanic crust is formed at mid-ocean ridges.
- The seafloor is spreading.

- 61 [1] Allow 1 credit. Acceptable responses include, but are not limited to:

- North American Plate and Eurasian Plate
- N. American Plate and African Plate

- 62 [1] Allow 1 credit if the center of the **X** is located on the trail on or between the 7960- and 8000-foot contour lines as shown below.
- 63 [1] Allow 1 credit for *both* an arrow on the map showing the stream flowing toward the northeast *and* for correct supporting evidence. Acceptable evidence includes, but is not limited to:
- The stream is flowing from higher contour elevations to lower contour elevations.
 - Contour lines bend upstream when crossing a stream.
 - Vs in the contour lines point in the opposite direction of stream flow.

Example of a correctly placed X for question 62 and a correctly drawn arrow for question 63:

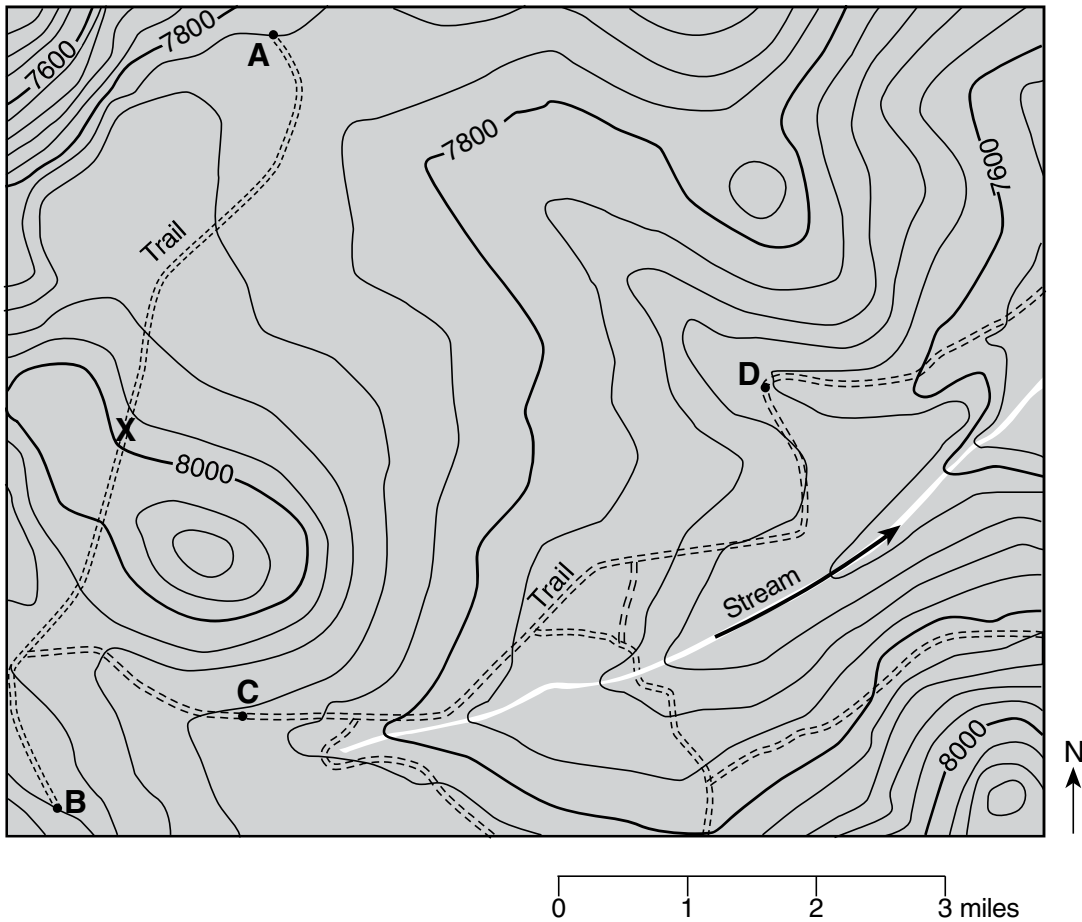

- 64 [1] Allow 1 credit for 40 ft.
- 65 [1] Allow 1 credit for any value from 1.8 h to 2.2 h.

Part C

Allow a maximum of 20 credits for this part.

66 [1] Allow 1 credit if the tops of *all nine* bars are within the ranges shown below.

Note: It is recommended that an overlay with the same scale as the student answer booklet be used to ensure reliability in rating.

Example of a 1-credit response:

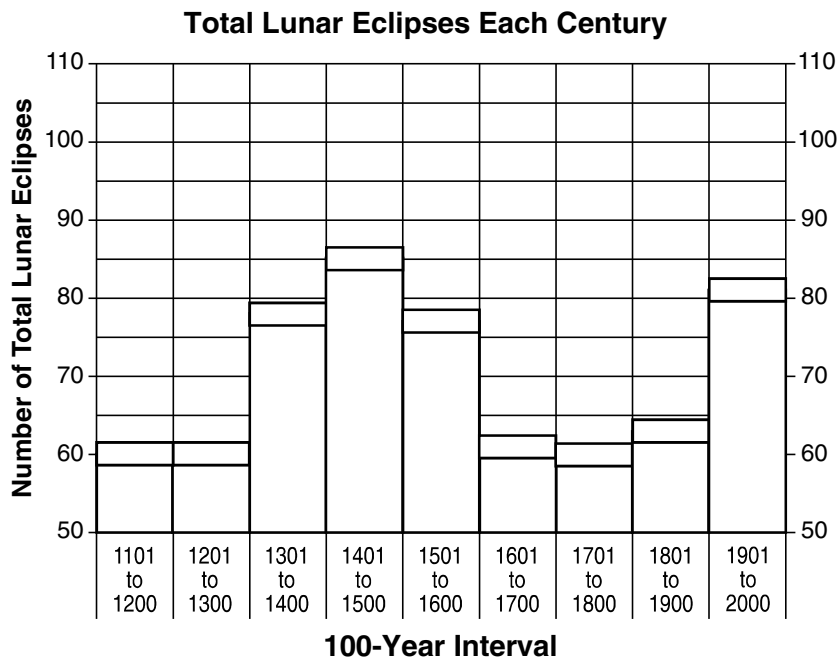

67 [1] Allow 1 credit. Acceptable responses include, but are not limited to:

- As the number of partial lunar eclipses increases, the number of total lunar eclipses decreases.
- The more partial lunar eclipses there are, the fewer total lunar eclipses there are.
- When the number of partial eclipses is high, the number of total eclipses is low.

68 [1] Allow 1 credit if the center of the **X** is within the rectangular zone shown below.

Note: It is recommended that an overlay of the same size as the student answer booklet be used to ensure reliability in rating.

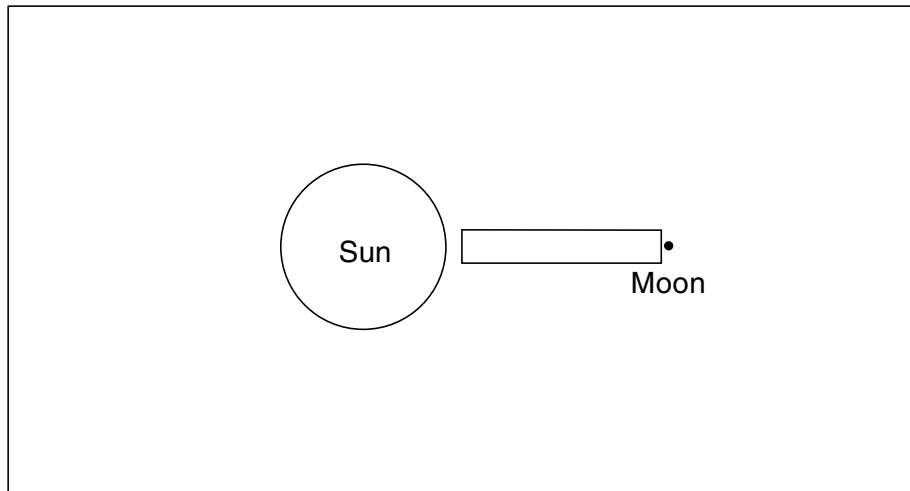

(Not drawn to scale)

69 [1] Allow 1 credit for clay *or* for a size equal to or less than 0.0004 cm.

70 [1] Allow 1 credit for *two* correct responses. Acceptable responses include, but are not limited to:

- cooling
- solidification
- crystallization
- melting
- intrusion/intruding

71 [1] Allow 1 credit. Acceptable responses include, but are not limited to:

- Basalt cuts across all other rock units.
- Contact metamorphism is shown between the basalt and all rock layers.

72 [1] Allow 1 credit for Ordovician Period.

73 [1] Allow 1 credit for marble *or* hornfels.

74 [1] Allow 1 credit. Acceptable responses include, but are not limited to:

- They are formed over a short period of time.
- They are geographically widespread.

- 75 [1] Allow 1 credit for a correctly drawn 60°F isotherm. If more than one isotherm is drawn, *all* isotherms must be correct to receive credit. The isotherm does *not* have to be labeled.

Example of a 1-credit response:



- 76 [1] Allow 1 credit for any value from 0.20 °F/mi to 0.30 °F/mi.

- 77 [1] Allow 1 credit. Acceptable responses include, but are not limited to:

- Miami is located at a lower latitude.
- Atlantic City receives a lower angle of insolation/less intense insolation.
- The temperatures in Miami are warmed by the Florida Current.
- Miami has a longer duration of insolation.

78 [1] Allow 1 credit. Acceptable responses include, but are not limited to:

- expansion
- cooling to the dewpoint
- condensation
- cooling
- deposition

79 [1] Allow 1 credit. Acceptable responses include, but are not limited to:

- Its warmest months are in January and February.
- Its coldest months are in June and July.
- The warm and cold times of the year are the opposite of New York's.

80 [1] Allow 1 credit if the climate is identified as dry and an **X** is placed anywhere on the leeward side of the mountain range.

Example of a correctly placed X:

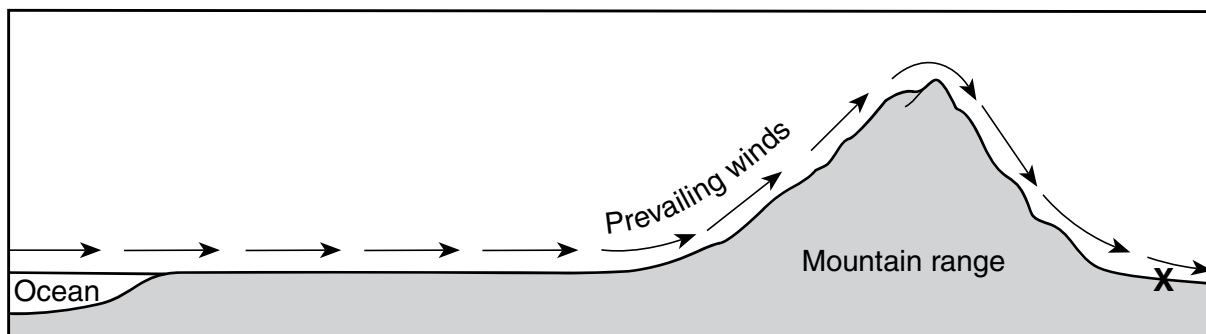

- 81 [1] Allow 1 credit if the axis line is drawn through Earth at location A within the stippled areas shown below and the North Pole is correctly labeled.

Note: It is recommended that an overlay of the same size as the student answer booklet be used to ensure reliability in rating.

- 82 [1] Allow 1 credit for an arrow at location D that shows a general west to east rotation. Allow credit if the arrow showing the direction of Earth's rotation is correctly drawn at location A.

Example of a 2-credit response for questions 81 and 82:

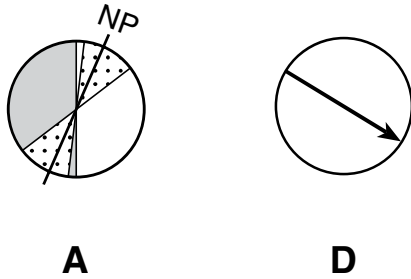

Note: Allow credit if the student labels the North Pole at the bottom, as shown below.

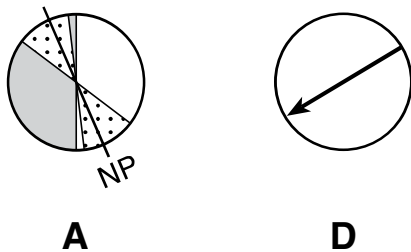

- 83 [1] Allow 1 credit for any value from 88 d to 94 d.

- 84 [1] Allow 1 credit. Acceptable responses include, but are not limited to:

- Earth's distance to the Sun is increasing.
- Earth is getting farther from the Sun.
- Earth is approaching aphelion.

- 85 [1] Allow 1 credit. Acceptable responses include, but are not limited to:

- The nighttime side of Earth at location A faces a different region of space than at location C.
- Earth is on different sides of the Sun in its orbit at locations A and C.
- Earth revolves around the Sun, so locations A and C have different views of the night sky.

Regents Examination in Physical Setting/Earth Science

August 2012

Chart for Converting Total Test Raw Scores to Final Examination Scores (Scale Scores)

The Chart for Determining the Final Examination Score for the August 2012 Regents Examination in Physical Setting/Earth Science will be posted on the Department's web site at: <http://www.p12.nysed.gov/apda/> on Friday, August 17, 2012. Conversion charts provided for previous administrations of the Regents Examination in Physical Setting/Earth Science must NOT be used to determine students' final scores for this administration.

Online Submission of Teacher Evaluations of the Test to the Department

Suggestions and feedback from teachers provide an important contribution to the test development process. The Department provides an online evaluation form for State assessments. It contains spaces for teachers to respond to several specific questions and to make suggestions. Instructions for completing the evaluation form are as follows:

1. Go to <http://www.forms2.nysed.gov/emsc/osa/exameval/reexameval.cfm>.
2. Select the test title.
3. Complete the required demographic fields.
4. Complete each evaluation question and provide comments in the space provided.
5. Click the **SUBMIT** button at the bottom of the page to submit the completed form.

Map to Core Curriculum

August 2012 Physical Setting/Earth Science			
Question Numbers			
Key Ideas/Performance Indicators	Part A	Part B	Part C
Standard 1			
Math Key Idea 1	5, 14	36, 39, 44, 58, 64, 65	76
Math Key Idea 2	3	59, 62	66, 67, 75, 79, 83, 85
Math Key Idea 3			
Science Inquiry Key Idea 1	1, 2, 4, 8, 18, 21, 23, 30, 35	43, 46, 49, 50, 51, 52, 53, 57, 60, 63	71, 74, 77, 78, 80, 85
Science Inquiry Key Idea 2			
Science Inquiry Key Idea 3			
Engineering Design Key Idea 1			
Standard 2			
Key Idea 1		48	
Key Idea 2			
Key Idea 3			
Standard 6			
Key Idea 1	9, 12, 17, 20, 22, 25, 28, 32	38, 40, 43, 46, 47, 48, 50, 51, 57	68, 70, 78, 81, 82, 85
Key Idea 2	2, 7, 10, 11, 13, 15, 16, 17, 18, 19, 24, 25, 28, 29, 31, 34, 35	37, 38, 39, 40, 41, 42, 45, 54, 55, 56, 58, 59, 61	68, 69, 70, 71, 72, 73, 75, 77, 80, 81, 82, 85
Key Idea 3	27	62, 64, 65	76
Key Idea 4		53	
Key Idea 5	6, 19, 21, 23, 33	42, 44, 47, 48, 49, 52, 59, 60, 62, 63	75, 77, 79, 80, 81
Key Idea 6			
Standard 7			
Key Idea 1			
Key Idea 2		65	67
Standard 4			
Key Idea 1	1, 2, 3, 4, 5, 7, 8, 11, 13, 25, 26, 27, 28, 29, 30, 31	36, 37, 39, 40, 49, 50, 56	66, 67, 68, 71, 72, 74, 81, 82, 83, 84, 85
Key Idea 2	6, 9, 10, 12, 14, 15, 16, 17, 18, 19, 20, 32, 33, 34, 35	38, 41, 42, 43, 44, 45, 46, 47, 48, 51, 52, 53, 54, 57, 58, 59, 60, 61, 62, 63, 64, 65	75, 76, 77, 78, 79, 80
Key Idea 3	21, 22, 23, 24	55	69, 70, 73
Reference Tables			
ESRT 2011 Edition (Revised)	3, 7, 8, 11, 13, 14, 15, 16, 18, 20, 21, 22, 23, 24, 27, 31, 32	36, 37, 38, 41, 44, 45, 46, 48, 49, 52, 53, 54, 55, 56, 60, 61, 65	69, 70, 72, 73, 74, 76

The State Education Department / The University of the State of New York
Regents Examination in Physical Setting/Earth Science – August 2012
Chart for Converting Total Test Raw Scores to Final Examination Scores (Scale Scores)
(Not to be used for the Braille Edition)

To determine the student's final score, locate the student's Total Performance Test Score across the top of the chart and the Total Written Test Score down the side of the chart. The point where the two scores intersect is the student's final examination score. For example, a student receiving a Total Performance Test Score of 10 and Total Written Test Score of 71 would receive a final examination score of 90.

		Total Performance Test Score																
		16	15	14	13	12	11	10	9	8	7	6	5	4	3	2	1	0
Total Written Test Score	85	100	99	99	99	98	98	97	96	96	95	94	93	91	90	88	87	85
	84	99	99	98	98	98	97	96	96	95	94	93	92	91	89	88	86	84
	83	99	99	98	98	98	97	96	96	95	94	93	92	91	89	88	86	84
	82	98	98	98	97	97	96	95	95	94	93	92	91	90	88	87	85	83
	81	98	98	98	97	97	96	95	95	94	93	92	91	90	88	87	85	83
	80	97	97	97	96	96	95	95	94	93	92	91	90	89	88	86	84	82
	79	97	96	96	95	95	94	94	93	92	91	90	89	88	87	85	83	82
	78	97	96	96	95	95	94	94	93	92	91	90	89	88	87	85	83	82
	77	96	95	95	95	94	94	93	92	91	91	89	88	87	86	84	83	81
	76	95	95	94	94	93	93	92	91	91	90	89	88	86	85	83	82	80
	75	95	95	94	94	93	93	92	91	91	90	89	88	86	85	83	82	80
	74	94	94	93	93	92	92	91	90	90	89	88	87	86	84	83	81	79
	73	93	93	92	92	92	91	90	90	89	88	87	86	85	83	82	80	78
	72	93	93	92	92	92	91	90	90	89	88	87	86	85	83	82	80	78
	71	92	92	92	91	91	90	90	89	88	87	86	85	84	82	81	79	77
	70	92	91	91	90	90	89	89	88	87	86	85	84	83	82	80	78	77
	69	91	90	90	89	89	88	88	87	86	85	84	83	82	81	79	77	76
	68	90	90	89	89	88	88	87	86	85	85	84	82	81	80	78	77	75
	67	90	90	89	89	88	88	87	86	85	85	84	82	81	80	78	77	75
	66	89	89	88	88	87	87	86	85	85	84	83	82	80	79	77	76	74
65	88	88	87	87	86	86	85	85	84	83	82	81	80	78	77	75	73	
64	87	87	87	86	86	85	84	84	83	82	81	80	79	77	76	74	72	
63	86	86	86	85	85	84	84	83	82	81	80	79	78	77	75	73	71	
62	86	85	85	84	84	83	83	82	81	80	79	78	77	76	74	72	71	
61	85	84	84	84	83	82	82	81	80	79	78	77	76	75	73	72	70	
60	84	84	83	83	82	82	81	80	80	79	78	77	75	74	72	71	69	
59	83	83	82	82	81	81	80	79	79	78	77	76	74	73	71	70	68	
58	83	83	82	82	81	81	80	79	79	78	77	76	74	73	71	70	68	
57	82	82	81	81	81	80	79	79	78	77	76	75	74	72	71	69	67	
56	81	81	81	80	80	79	78	78	77	76	75	74	73	71	70	68	66	
55	80	80	80	79	79	78	78	77	76	75	74	73	72	71	69	67	65	
54	80	79	79	78	78	77	77	76	75	74	73	72	71	70	68	66	65	
53	79	78	78	78	77	77	76	75	74	74	72	71	70	69	67	66	64	
52	78	78	77	77	76	76	75	74	74	73	72	71	69	68	66	65	63	
51	77	77	76	76	75	75	74	73	73	72	71	70	69	67	66	64	62	
50	76	76	75	75	75	74	73	73	72	71	70	69	68	66	65	63	61	
49	75	75	75	74	74	73	73	72	71	70	69	68	67	65	64	62	60	
48	75	74	74	73	73	72	72	71	70	69	68	67	66	65	63	61	60	
47	73	73	72	72	71	71	70	69	68	68	67	66	65	64	63	61	58	
46	72	72	71	71	70	70	69	68	68	67	66	65	63	62	60	59	57	
45	71	71	70	70	69	69	68	68	67	66	65	64	63	61	60	58	56	

**Final Examination Scores
 Regents Examination in Physical Setting/Earth Science – August 2012 – continued**

		Total Performance Test Score																	
		16	15	14	13	12	11	10	9	8	7	6	5	4	3	2	1	0	
Total Written Test Score	44	70	70	70	69	69	68	67	67	66	65	64	63	62	60	59	57	55	
	43	69	69	69	68	68	67	67	66	65	64	63	62	61	60	58	56	54	
	42	69	68	68	67	67	66	66	65	64	63	62	61	60	59	57	55	54	
	41	68	67	67	67	66	65	65	64	63	62	61	60	59	58	56	55	53	
	40	67	67	66	66	65	65	64	63	63	62	61	60	58	57	55	54	52	
	39	65	65	64	64	64	63	62	62	61	60	59	58	57	55	54	52	50	
	38	64	64	64	63	63	62	61	61	60	59	58	57	56	54	53	51	49	
	37	63	63	63	62	62	61	61	60	59	58	57	56	55	54	52	50	48	
	36	63	62	62	61	61	60	60	59	58	57	56	55	54	53	51	49	48	
	35	61	61	60	60	59	59	58	57	57	56	55	54	52	51	49	48	46	
	34	60	60	59	59	58	58	57	57	56	56	55	54	53	52	50	49	47	45
	33	59	59	58	58	58	57	56	56	55	54	53	52	51	49	48	46	44	
	32	58	58	58	57	57	56	56	55	54	53	52	51	50	48	47	45	43	
	31	57	56	56	55	55	54	54	53	52	51	50	49	48	47	45	43	42	
	30	56	56	55	55	54	54	53	52	51	51	50	49	48	46	44	43	41	
	29	55	55	54	54	53	53	52	51	51	50	49	48	46	45	43	42	40	
	28	53	53	53	52	52	51	50	50	49	48	47	46	45	43	42	40	38	
	27	52	52	52	51	51	50	50	49	48	47	46	45	44	43	41	39	37	
	26	51	50	50	50	49	48	48	47	46	45	44	43	42	41	39	38	36	
	25	50	50	49	49	48	48	47	46	46	45	44	43	41	40	38	37	35	
	24	49	49	48	48	47	47	46	45	45	44	43	42	40	39	37	36	34	
23	47	47	47	46	46	45	44	44	43	42	41	40	39	37	36	34	32		
22	46	46	46	45	45	44	44	43	42	41	40	39	38	37	35	33	31		
21	45	44	44	44	43	43	42	41	40	40	38	37	36	35	33	32	30		
20	44	44	43	43	42	42	41	40	40	39	38	37	35	34	32	31	29		
19	42	42	41	41	41	40	39	39	38	37	36	35	34	32	31	29	27		
18	41	41	41	40	40	39	39	38	37	36	35	34	33	31	30	28	26		
17	40	39	39	38	38	37	37	36	35	34	33	32	31	30	28	26	25		
16	39	39	38	38	37	37	36	35	34	34	33	31	30	29	27	26	24		
15	37	37	36	36	35	35	34	34	33	32	31	30	29	27	26	24	22		
14	35	35	35	34	34	33	33	32	31	30	29	28	27	26	24	22	20		
13	35	34	34	33	33	32	32	31	30	29	28	27	26	25	23	21	20		
12	33	33	32	32	31	31	30	29	29	28	27	26	24	23	21	20	18		
11	31	31	30	30	30	29	28	28	27	26	25	24	23	21	20	18	16		
10	30	30	30	29	29	28	27	27	26	25	24	23	22	20	19	17	15		
9	29	28	28	27	27	26	26	25	24	23	22	21	20	19	17	15	14		
8	27	27	26	26	25	25	24	23	23	22	21	20	18	17	15	14	12		
7	26	26	25	25	24	24	23	22	22	21	20	19	18	16	15	13	11		
6	24	24	24	23	23	22	22	21	20	19	18	17	16	14	13	11	9		
5	23	22	22	21	21	20	20	19	18	17	16	15	14	13	11	9	8		
4	21	21	20	20	19	19	18	17	17	16	15	14	12	11	9	8	6		
3	20	20	19	19	18	18	17	17	16	15	14	13	12	10	9	7	5		
2	18	18	18	17	17	16	16	15	14	13	12	11	10	9	7	5	3		
1	17	16	16	16	15	14	14	13	12	11	10	9	8	7	5	4	2		
0	15	15	14	14	13	13	12	11	11	10	9	8	6	5	3	2	0		