

Lesson 3-1: Solving Two-Step Equations

Part 1: Solving Two-Step Equations

1. 010636a, P.I. A.A.22

Solve for x : $\frac{1}{16}x + \frac{1}{4} = \frac{1}{2}$

2. 080708a, P.I. A.A.22

In the equation $\frac{1}{4}n + 5 = 5\frac{1}{2}$, n is equal to

[A] $\frac{1}{8}$ [B] 8 [C] $\frac{1}{2}$ [D] 2

3. 080219a, P.I. A.A.6

If $2x + 5 = -25$ and $-3m - 6 = 48$, what is the product of x and m ?

[A] 270 [B] -33 [C] 3 [D] -270

4. 060519a, P.I. A.A.6

If $-2x + 3 = 7$ and $3x + 1 = 5 + y$, the value of y is

[A] 10 [B] 0 [C] 1 [D] -10

5. 080213a, P.I. A.A.6

How many times larger than $\frac{1}{4}x$ is $5x$?

[A] 9 [B] 20 [C] $\frac{4}{5}$ [D] $\frac{5}{4}$

6. 010801a, P.I. A.A.6

Robin spent \$17 at an amusement park for admission and rides. If she paid \$5 for admission, and rides cost \$3 each, what is the total number of rides that she went on?

[A] 2 [B] 12 [C] 4 [D] 9

7. 060409a, P.I. A.A.6

At the beginning of her mathematics class, Mrs. Reno gives a warm-up problem. She says, "I am thinking of a number such that 6 less than the product of 7 and this number is 85." Which number is she thinking of?

[A] $11\frac{2}{7}$ [B] 13 [C] 637 [D] 84

8. 010733a, P.I. A.A.6

Every month, Omar buys pizzas to serve at a party for his friends. In May, he bought three more than twice the number of pizzas he bought in April. If Omar bought 15 pizzas in May, how many pizzas did he buy in April?

9. 060233a, P.I. A.N.5

Mr. Perez owns a sneaker store. He bought 350 pairs of basketball sneakers and 150 pairs of soccer sneakers from the manufacturers for \$62,500. He sold all the sneakers and made a 25% profit. If he sold the soccer sneakers for \$130 per pair, how much did he charge for one pair of basketball sneakers?

Lesson 3-2: Solving Multi-Step Equations

Part 1: Using the Distributive Property to Combine Like Terms

10. What is the solution of the equation $3y - 5y + 10 = 36$?

[A] -13 [B] 2 [C] 4.5 [D] 13

11. Sara's telephone service costs \$21 per month plus \$0.25 for each local call, and long-distance calls are extra. Last month, Sara's bill was \$36.64, and it included \$6.14 in long-distance charges. How many local calls did she make?

12. What is the value of x in the equation

$$\frac{x}{2} + \frac{x}{6} = 2?$$

- [A] 3 [B] $\frac{1}{4}$ [C] 8 [D] 12

13. What is the solution set of the equation

$$\frac{x}{5} + \frac{x}{2} = 14?$$

- [A] {10} [B] {4} [C] {20} [D] {49}

Part 2: Using the Distributive Property to Solve Equations

14. Solve for x : $15x - 3(3x + 4) = 6$

- [A] $\frac{1}{3}$ [B] $-\frac{1}{2}$ [C] 1 [D] 3

15. What is the value of n in the equation $0.6(n + 10) = 3.6$?

- [A] 5 [B] -4 [C] -0.4 [D] 4

16. What is the value of p in the equation $2(3p - 4) = 10$?

- [A] $\frac{1}{3}$ [B] $2\frac{1}{3}$ [C] 3 [D] 1

17. Parking charges at Superior Parking Garage are \$5.00 for the first hour and \$1.50 for each additional 30 minutes. If Margo has \$12.50, what is the maximum amount of time she will be able to park her car at the garage?

- [A] $2\frac{1}{2}$ hours [B] $6\frac{1}{2}$ hours

- [C] $3\frac{1}{2}$ hours [D] 6 hours

18. Mario paid \$44.25 in taxi fare from the hotel to the airport. The cab charged \$2.25 for the first mile plus \$3.50 for each additional mile. How many miles was it from the hotel to the airport?

- [A] 12 [B] 13 [C] 11 [D] 10

19. A candy store sells 8-pound bags of mixed hazelnuts and cashews. If c pounds of cashews are in a bag, the price p of the bag can be found using the formula $p = 2.59c + 1.72(8 - c)$. If one bag is priced at \$18.11, how many pounds of cashews does it contain?

Lesson 3-3: Equations with Variables on Both Sides

Part 1: Solving Equations with Variables on Both Sides

20. 010807a, P.I. A.A.22
What is the value of p in the equation $8p + 2 = 4p - 10$?

- [A] -1 [B] 1 [C] -3 [D] 3

21. 010705a, P.I. A.A.22
What is the value of n in the equation $3n - 8 = 32 - n$?

- [A] -6 [B] -10 [C] 10 [D] 6

22. fall0732ia, P.I. A.A.22
Solve for g : $3 + 2g = 5g - 9$

23. 060323a, P.I. A.A.22
Solve for m : $0.6m + 3 = 2m + 0.2$

24. 089921a, P.I. A.A.22
Solve for x : $2(x - 3) = 1.2 - x$

25. 060404a, P.I. A.A.22
If $3(x - 2) = 2x + 6$, the value of x is

- [A] 12 [B] 20 [C] 0 [D] 5

26. 010401a, P.I. A.A.22
If $2(x + 3) = x + 10$, then x equals
[A] 4 [B] 5 [C] 7 [D] 14
27. 060602a, P.I. A.A.22
What is the value of x in the equation
 $13x - 2(x + 4) = 8x + 1$?
[A] 1 [B] 3 [C] 4 [D] 2
28. 060634a, P.I. A.A.22
Solve for x : $3.3 - x = 3(x - 1.7)$
29. 010601a, P.I. A.A.22
What is the value of x in the equation
 $5(2x - 7) = 15x - 10$?
[A] -5 [B] 0.6 [C] 1 [D] -9
30. 060702a, P.I. A.A.22
What is the value of x in the equation
 $6(x - 2) = 36 - 10x$?
[A] 3 [B] 6 [C] 1.5 [D] -6
31. 080731a, P.I. A.A.22
Solve for x : $5(x - 2) = 2(10 + x)$
32. 060704a, P.I. A.A.22
What is the value of w in the equation
 $\frac{1}{2}w + 7 = 2w - 2$?
[A] 6 [B] 3.6 [C] 2 [D] $3\frac{1}{3}$
33. 080620a, P.I. A.A.22
What is the value of w in the equation
 $\frac{3}{4}w + 8 = \frac{1}{3}w - 7$?
[A] -36 [B] -0.2 [C] -13.846 [D] 2.4
34. 010204a, P.I. A.A.22
What is the value of x in the equation
 $\frac{3}{4}x + 2 = \frac{5}{4}x - 6$?
[A] 16 [B] 4 [C] -4 [D] -16
35. 060310a, P.I. A.A.22
If $x + y = 9x + y$, then x is equal to
[A] y [B] 0 [C] 8 [D] $\frac{1}{5}y$
36. 010011a, P.I. A.A.22
If $9x + 2a = 3a - 4x$, then x equals
[A] $-a$ [B] $\frac{5a}{12}$ [C] a [D] $\frac{a}{13}$
37. 060513a, P.I. A.A.22
If $7x + 2a = 3x + 5a$, then x is equivalent to
[A] $\frac{3a}{4}$ [B] $\frac{3a}{10}$ [C] $\frac{7a}{4}$ [D] $\frac{7a}{10}$
38. 060111a, P.I. A.A.6
If one-half of a number is 8 less than two-thirds of the number, what is the number?
[A] 48 [B] 24 [C] 32 [D] 54
39. 060418a, P.I. A.A.6
The number of people on the school board is represented by x . Two subcommittees with an equal number of members are formed, one with $\frac{2}{3}x - 5$ members and the other with $\frac{x}{4}$ members. How many people are on the school board?
[A] 12 [B] 20 [C] 4 [D] 8

Review P. 140: Using and Transforming Formulas

40. If $2m + 2p = 16$, p equals

- [A] $8 - m$ [B] $16 - m$
[C] $16 + 2m$ [D] $9m$

41. If $bx - 2 = K$, then x equals

- [A] $\frac{2 - K}{b}$ [B] $\frac{K - 2}{b}$
[C] $\frac{K}{b} + 2$ [D] $\frac{K + 2}{b}$

42. If $c = 2m + d$, then m is equal to

- [A] $\frac{c - d}{2}$ [B] $\frac{c}{2} - d$
[C] $c - \frac{d}{2}$ [D] $d - 2c$

43. If $x = 2a - b^2$, then a equals

- [A] $\frac{b^2 - x}{2}$ [B] $\frac{x - b^2}{2}$
[C] $\frac{x + b^2}{2}$ [D] $x + b^2$

44. If $2ax - 5x = 2$, then x is equivalent to

- [A] $\frac{2 + 5a}{2a}$ [B] $7 - 2a$
[C] $\frac{1}{a - 5}$ [D] $\frac{2}{2a - 5}$

45. If $\frac{x}{4} - \frac{a}{b} = 0$, $b \neq 0$, then x is equal to

- [A] $-\frac{a}{4b}$ [B] $\frac{4a}{b}$ [C] $\frac{a}{4b}$ [D] $-\frac{4a}{b}$

46. Which equation is equivalent to $3x + 4y = 15$?

- [A] $y = 15 - 3x$ [B] $y = \frac{15 - 3x}{4}$
[C] $y = 3x - 15$ [D] $y = \frac{3x - 15}{4}$

47. The equation $P = 2L + 2W$ is equivalent to

- [A] $L = \frac{P + 2W}{2}$ [B] $L = P - W$
[C] $L = \frac{P - 2W}{2}$ [D] $2L = \frac{P}{2W}$

48. In the equation $A = p + prt$, t is equivalent to

- [A] $\frac{A - pr}{p}$ [B] $\frac{A - p}{pr}$
[C] $\frac{A}{pr} - p$ [D] $\frac{A}{P} - pr$

49. The formula for the volume of a right circular cylinder is $V = \pi r^2 h$. The value of h can be expressed as

- [A] $\frac{\pi r^2}{V}$ [B] $V - \pi r^2$
[C] $\frac{V}{\pi} r^2$ [D] $\frac{V}{\pi r^2}$

50. The formula for potential energy is $P = mgh$, where P is potential energy, m is mass, g is gravity, and h is height. Which expression can be used to represent g ?

- [A] $P - mh$ [B] $P - m - h$
[C] $\frac{P}{mh}$ [D] $\frac{P}{m} - h$

51. Shoe sizes and foot length are related by the formula $S = 3F - 24$, where S represents the shoe size and F represents the length of the foot, in inches.
- a Solve the formula for F .
- b To the *nearest tenth of an inch*, how long is the foot of a person who wears a size $10\frac{1}{2}$ shoe?

52. If $\sqrt{x-a} = b, x > a$, which expression is equivalent to x ?

- [A] $b^2 - a$ [B] $b - a$
[C] $b + a$ [D] $b^2 + a$

53. The volume of any spherical balloon can be found by using the formula $V = \frac{4}{3}\pi r^3$.
Write an equation for r in terms of V and π .

54. The slant height, ℓ , of the conical water tank shown in the accompanying diagram is

$\ell = \sqrt[3]{\frac{8v}{\pi}}$. Solve for v , in terms of ℓ and π .

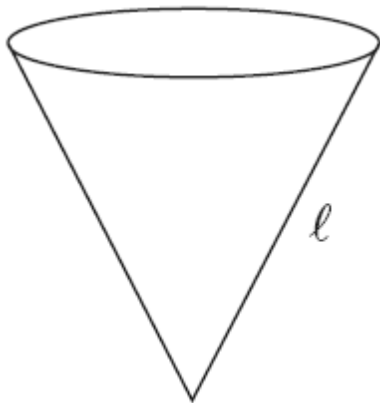

55. If the temperature in Buffalo is 23° Fahrenheit, what is the temperature in degrees Celsius? [Use the formula $C = \frac{5}{9}(F - 32)$.]

- [A] -5 [B] 45 [C] 5 [D] -45

56. The formula $C = \frac{5}{9}(F - 32)$ can be used to find the Celsius temperature (C) for a given Fahrenheit temperature (F). What Celsius temperature is equal to a Fahrenheit temperature of 77° ?

- [A] 171° [B] 8° [C] 45° [D] 25°

57. The formula for changing Celsius (C) temperature to Fahrenheit (F) temperature is $F = \frac{9}{5}C + 32$. Calculate, to the *nearest degree*, the Fahrenheit temperature when the Celsius temperature is -8 .

58. The formula $C = \frac{5}{9}(F - 32)$ is used to convert Fahrenheit temperature, F , to Celsius temperature, C . What temperature, in degrees Fahrenheit, is equivalent to a temperature of 10° Celsius?

59. Connor wants to compare Celsius and Fahrenheit temperatures by drawing a conversion graph. He knows that $-40^\circ C = -40^\circ F$ and that $20^\circ C = 68^\circ F$. On the accompanying grid, construct the conversion graph and, using the graph, determine the Celsius equivalent of $25^\circ F$.

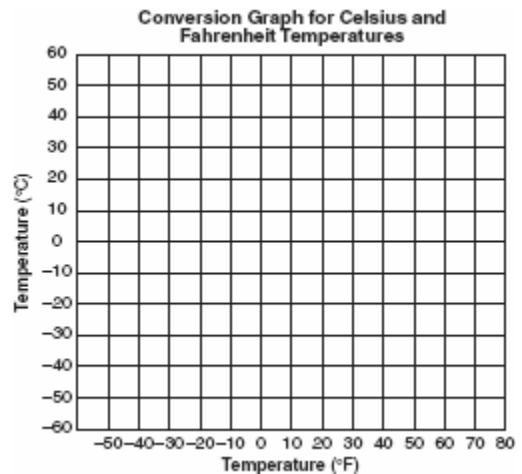

Lesson 3-4: Ratio and Proportion

Part 1: Ratios and Rates

60. 080002a, P.I. A.A.1
A hockey team played n games, losing four of them and winning the rest. The ratio of games won to games lost is
- [A] $\frac{n}{4}$ [B] $\frac{4}{n-4}$ [C] $\frac{n-4}{4}$ [D] $\frac{4}{n}$
61. 060223a, P.I. A.A.26
If the instructions for cooking a turkey state "Roast turkey at 325° for 20 minutes per pound," how many hours will it take to roast a 20-pound turkey at 325° ?
62. 010117a, P.I. A.A.26
In a molecule of water, there are two atoms of hydrogen and one atom of oxygen. How many atoms of hydrogen are in 28 molecules of water?
- [A] 42 [B] 56 [C] 14 [D] 29
63. 060505a, P.I. A.A.26
A cake recipe calls for 1.5 cups of milk and 3 cups of flour. Seth made a mistake and used 5 cups of flour. How many cups of milk should he use to keep the proportions correct?
- [A] 2.25 [B] 2.5 [C] 2 [D] 1.75
64. 069913a, P.I. A.A.26
A total of \$450 is divided into equal shares. If Kate receives four shares, Kevin receives three shares, and Anna receives the remaining two shares, how much money did Kevin receive?
- [A] \$200 [B] \$150
[C] \$100 [D] \$250
65. 069915a, P.I. A.A.26
During a recent winter, the ratio of deer to foxes was 7 to 3 in one county of New York State. If there were 210 foxes in the county, what was the number of deer in the county?
- [A] 280 [B] 490 [C] 90 [D] 147
66. 010014a, P.I. A.A.26
Sterling silver is made of an alloy of silver and copper in the ratio of 37:3. If the mass of a sterling silver ingot is 600 grams, how much silver does it contain?
- [A] 450 g [B] 555 g
[C] 48.65 g [D] 200 g
67. 010210a, P.I. A.A.26
There are 357 seniors in Harris High School. The ratio of boys to girls is 7:10. How many boys are in the senior class?
- [A] 117 [B] 147 [C] 107 [D] 210
68. 089931a, P.I. A.A.26
The profits in a business are to be shared by the three partners in the ratio of 3 to 2 to 5. The profit for the year was \$176,500. Determine the number of dollars each partner is to receive.
69. 010331a, P.I. A.A.26
At the Phoenix Surfboard Company, \$306,000 in profits was made last year. This profit was shared by the four partners in the ratio 3:3:5:7. How much *more* money did the partner with the largest share make than one of the partners with the smallest share?
70. 010427a, P.I. A.A.1
Which expression represents the number of yards in x feet?
- [A] $12x$ [B] $\frac{x}{12}$ [C] $3x$ [D] $\frac{x}{3}$

71. 060014a, P.I. A.A.1
If rain is falling at the rate of 2 inches per hour, how many inches of rain will fall in x minutes?

[A] $\frac{30}{x}$ [B] $\frac{x}{30}$ [C] $\frac{60}{x}$ [D] $2x$

72. 060709a, P.I. A.M.2
Andy is 6 feet tall. If 1 inch equals 2.54 centimeters, how tall is Andy, to the *nearest centimeter*?

[A] 30 [B] 183 [C] 213 [D] 15

73. 060731a, P.I. A.M.2
If a United States dollar is worth \$1.41 in Canadian money, how much is \$100 in Canadian money worth in United States money, to the *nearest cent*?

74. 080415a, P.I. A.A.26
A rocket car on the Bonneville Salt Flats is traveling at a rate of 640 miles per hour. How much time would it take for the car to travel 384 miles at this rate?

[A] 245 minutes [B] 1.7 hours
[C] 256 minutes [D] 36 minutes

75. 080632a, P.I. A.A.26
Running at a constant speed, Andrea covers 15 miles in $2\frac{1}{2}$ hours. At this speed, how many *minutes* will it take her to run 2 miles?

76. 069926a, P.I. 8.G.13
During a 45-minute lunch period, Albert (A) went running and Bill (B) walked for exercise. Their times and distances are shown in the accompanying graph. How much faster was Albert running than Bill was walking, in miles per hour?

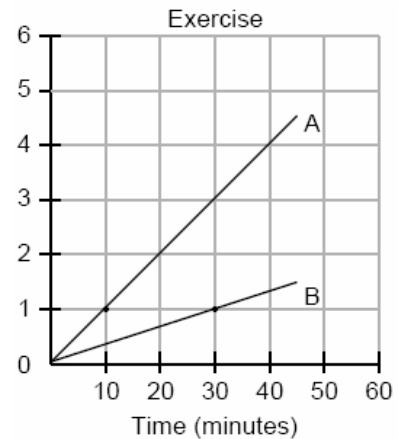

77. 060116b, P.I. A.M.1
On her first trip, Sari biked 24 miles in T hours. The following week Sari biked 32 miles in T hours. Determine the ratio of her average speed on her second trip to her average speed on her first trip.

[A] $\frac{3}{2}$ [B] $\frac{3}{4}$ [C] $\frac{2}{3}$ [D] $\frac{4}{3}$

78. 080111b, P.I. A.M.1
On a trip, a student drove 40 miles per hour for 2 hours and then drove 30 miles per hour for 3 hours. What is the student's average rate of speed, in miles per hour, for the whole trip?

[A] 35 [B] 36 [C] 37 [D] 34

79. 080119b, P.I. A.M.1
If Jamar can run $\frac{3}{5}$ of a mile in 2 minutes 30 seconds, what is his rate in miles per minute?
[A] $4\frac{1}{6}$ [B] $\frac{6}{25}$ [C] $\frac{4}{5}$ [D] $3\frac{1}{10}$
80. 080736a, P.I. A.M.1
The trip from Manhattan to Montauk Point is 120 miles by train or by car. A train makes the trip in 2 hours, while a car makes the trip in $2\frac{1}{2}$ hours. How much faster, in miles per hour, is the average speed of the train than the average speed of the car?
81. fall0734ia, P.I. A.M.1
Hannah took a trip to visit her cousin. She drove 120 miles to reach her cousin's house and the same distance back home. It took her 1.2 hours to get halfway to her cousin's house. What was her average speed, in miles per hour, for the first 1.2 hours of the trip? Hannah's average speed for the remainder of the trip to her cousin's house was 40 miles per hour. How long, in hours, did it take her to drive the remaining distance? Traveling home along the same route, Hannah drove at an average rate of 55 miles per hour. After 2 hours her car broke down. How many miles was she from home?
83. 010818a, P.I. A.A.26
On a map, 1 inch represents 3 miles. How many miles long is a road that is $2\frac{1}{2}$ inches long on the map?
[A] $7\frac{1}{2}$ [B] $5\frac{1}{2}$ [C] $6\frac{1}{2}$ [D] $\frac{1}{2}$
84. 080603a, P.I. A.A.26
Jordan and Missy are standing together in the schoolyard. Jordan, who is 6 feet tall, casts a shadow that is 54 inches long. At the same time, Missy casts a shadow that is 45 inches long. How tall is Missy?
[A] 5 ft 6 in [B] 5 ft
[C] 38 in [D] 86.4 in
85. 080223a, P.I. A.A.26
An image of a building in a photograph is 6 centimeters wide and 11 centimeters tall. If the image is similar to the actual building and the actual building is 174 meters wide, how tall is the actual building, in meters?
86. 060124a, P.I. A.A.26
If a girl 1.2 meters tall casts a shadow 2 meters long, how many meters tall is a tree that casts a shadow 75 meters long at the same time?
87. 010222a, P.I. A.A.26
A 12-foot tree casts a 16-foot shadow. How many feet tall is a nearby tree that casts a 20-foot shadow at the same time?

Lesson 3-5: Proportions and Similar Figures

Part 2: Indirect Measurement and Scale Drawings

82. 080201a, P.I. A.A.26
On a map, 1 centimeter represents 40 kilometers. How many kilometers are represented by 8 centimeters?
[A] 5 [B] 48 [C] 280 [D] 320

Lesson 3-6: Equations and Problem Solving

Part 1: Defining Variables

88. 080024a, P.I. A.A.6
The sum of the ages of the three Romano brothers is 63. If their ages can be represented as consecutive integers, what is the age of the middle brother?

Part 2: Distance-Rate-Time Problems

89. 060101a, P.I. A.A.1
A car travels 110 miles in 2 hours. At the same rate of speed, how far will the car travel in h hours?

[A] $55h$ [B] $\frac{h}{55}$ [C] $220h$ [D] $\frac{h}{220}$

90. 010027a, P.I. A.A.6
A truck traveling at a constant rate of 45 miles per hour leaves Albany. One hour later a car traveling at a constant rate of 60 miles per hour also leaves Albany traveling in the same direction on the same highway. How long will it take for the car to catch up to the truck, if both vehicles continue in the same direction on the highway?

91. 080518a, P.I. A.A.6
A bicyclist leaves Bay Shore traveling at an average speed of 12 miles per hour. Three hours later, a car leaves Bay Shore, on the same route, traveling at an average speed of 30 miles per hour. How many hours after the car leaves Bay Shore will the car catch up to the cyclist?

[A] 5 [B] 4 [C] 8 [D] 2

92. 060010a, P.I. A.A.6
A truck travels 40 miles from point A to point B in exactly 1 hour. When the truck is halfway between point A and point B , a car starts from point A and travels at 50 miles per hour. How many miles has the car traveled when the truck reaches point B ?

[A] 50 [B] 40 [C] 60 [D] 25

93. 010125a, P.I. A.A.6
Two trains leave the same station at the same time and travel in opposite directions. One train travels at 80 kilometers per hour and the other at 100 kilometers per hour. In how many hours will they be 900 kilometers apart?

94. 010433a, P.I. A.A.6
Bob and Latoya both drove to a baseball game at a college stadium. Bob lives 70 miles from the stadium and Latoya lives 60 miles from it, as shown in the accompanying diagram. Bob drove at a rate of 50 miles per hour, and Latoya drove at a rate of 40 miles per hour. If they both left home at the same time, who got to the stadium first?

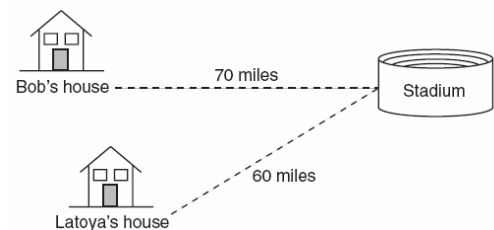

95. 080019a, P.I. A.A.6
A girl can ski down a hill five times as fast as she can climb up the same hill. If she can climb up the hill and ski down in a total of 9 minutes, how many minutes does it take her to climb up the hill?

[A] 7.5 [B] 1.8 [C] 7.2 [D] 4.5

Review P. 166: Proportions and Percents

96. 010732a, P.I. A.N.5
A 14-gram serving of mayonnaise contains 11 grams of fat. What percent of the mayonnaise, to the *nearest tenth of a percent*, is fat?
97. 080635a, P.I. A.N.5
A recent survey shows that the average man will spend 141,288 hours sleeping, 85,725 hours working, 81,681 hours watching television, 9,945 hours commuting, 1,662 hours kissing, and 363,447 hours on other tasks during his lifetime. What percent of his life, to the *nearest tenth of a percent*, does he spend sleeping?
98. 010009a, P.I. A.N.5
Twenty-five percent of 88 is the same as what percent of 22?
- [A] 100% [B] $12\frac{1}{2}\%$
[C] 40% [D] 50%
99. 060222a, P.I. A.N.5
Ninety percent of the ninth grade students at Richbartville High School take algebra. If 180 ninth grade students take algebra, how many ninth grade students do *not* take algebra?
100. 069910a, P.I. A.N.5
Linda paid \$48 for a jacket that was on sale for 25% of the original price. What was the original price of the jacket?
- [A] \$192 [B] \$72 [C] \$96 [D] \$60
101. 010122a, P.I. A.N.5
Sue bought a picnic table on sale for 50% off the original price. The store charged her 10% tax and her final cost was \$22.00. What was the original price of the picnic table?
102. 089930a, P.I. A.N.5
A painting that regularly sells for a price of \$55 is on sale for 20% off. The sales tax on the painting is 7%. Will the final total cost of the painting differ depending on whether the salesperson deducts the discount before adding the sales tax or takes the discount after computing the sum of the original price and the sales tax on \$55?
103. 080436a, P.I. A.N.5
Walter is a waiter at the Towne Diner. He earns a daily wage of \$50, plus tips that are equal to 15% of the total cost of the dinners he serves. What was the total cost of the dinners he served if he earned \$170 on Tuesday?
104. 080225a, P.I. A.N.5
In bowling leagues, some players are awarded extra points called their "handicap." The "handicap" in Anthony's league is 80% of the difference between 200 and the bowler's average. Anthony's average is 145. What is Anthony's "handicap"?
105. 010626a, P.I. A.N.5
The Edison Lightbulb Company tests 5% of their daily production of lightbulbs. If 500 bulbs were tested on Tuesday, what was the total number of bulbs produced that day?
- [A] 25 [B] 1,000
[C] 10,000 [D] 100,000

Lesson 3-7: Percent of Change

Part 1: Percent of Change

106. 010322a, P.I. A.N.5
The world population was 4.2 billion people in 1982. The population in 1999 reached 6 billion. Find the percent of change from 1982 to 1999.

107. 060420a, P.I. A.N.5
Rashawn bought a CD that cost \$18.99 and paid \$20.51, including sales tax. What was the rate of the sales tax?

- [A] 8% [B] 3% [C] 5% [D] 2%

Part 2: Percent Error

108. fall0723ia, P.I. A.M.3
The groundskeeper is replacing the turf on a football field. His measurements of the field are 130 yards by 60 yards. The actual measurements are 120 yards by 54 yards. Which expression represents the relative error in the measurement?

- [A] $\frac{(120)(54)}{(130)(60) - (120)(54)}$
[B] $\frac{(130)(60) - (120)(54)}{(120)(54)}$
[C] $\frac{(130)(60)}{(130)(60) - (120)(54)}$
[D] $\frac{(130)(60) - (120)(54)}{(130)(60)}$

109. 060127a, P.I. A.N.5
A factory packs CD cases into cartons for a music company. Each carton is designed to hold 1,152 CD cases. The Quality Control Unit in the factory expects an error of less than 5% over or under the desired packing number. What is the *least* number and the *most* number of CD cases that could be packed in a carton and still be acceptable to the Quality Control Unit?

Lesson 3-8: Finding and Estimating Square Roots

Part 1: Finding Square Roots

110. 060706a
The expression $\sqrt{54 - b}$ is equivalent to a positive integer when b is equal to
[A] 54 [B] -10 [C] 4 [D] 16

Part 2: Estimating and Using Square Roots

111. 010001a, P.I. 7.N.18
The expression $\sqrt{93}$ is a number between
[A] 46 and 47 [B] 3 and 9
[C] 9 and 10 [D] 8 and 9

112. 010703a, P.I. 7.N.18
Which point on the accompanying number line best represents the position of $\sqrt{5}$?



- [A] C [B] D [C] A [D] B

113. 060502a, P.I. 7.A.6
The amount of time, t , in seconds, it takes an object to fall a distance, d , in meters, is expressed by the formula $t = \sqrt{\frac{d}{4.9}}$.
- Approximately how long will it take an object to fall 75 meters?
- [A] 2.34 sec [B] 3.9 sec
[C] 0.26 sec [D] 7.7 sec

118. 060710a, P.I. A.A.45
If the length of a rectangular television screen is 20 inches and its height is 15 inches, what is the length of its diagonal, in inches?
- [A] 35 [B] 13.2 [C] 25 [D] 5
119. 010508a, P.I. A.A.45
The NuFone Communications Company must run a telephone line between two poles at opposite ends of a lake, as shown in the accompanying diagram. The length and width of the lake are 75 feet and 30 feet, respectively.

Lesson 3-9: The Pythagorean Theorem

Part 1: Solving Problems Using the Pythagorean Theorem

114. 060009a, P.I. G.G.48
The set of integers {3,4,5} is a Pythagorean triple. Another such set is
- [A] {6,7,8} [B] {6,8,12}
[C] {8,15,17} [D] {6,12,13}
115. 010827a, P.I. G.G.48
Which set of numbers could be the lengths of the sides of a right triangle?
- [A] {4,7,8} [B] {12,16,30}
[C] {3,4,6} [D] {10,24,26}
116. 010615a, P.I. G.G.48
A builder is building a rectangular deck with dimensions of 16 feet by 30 feet. To ensure that the sides form 90° angles, what should each diagonal measure?
- [A] 30 ft [B] 34 ft [C] 46 ft [D] 16 ft
117. 010202a, P.I. A.A.45
If the length of the legs of a right triangle are 5 and 7, what is the length of the hypotenuse?
- [A] $\sqrt{2}$ [B] $\sqrt{74}$
[C] $2\sqrt{6}$ [D] $2\sqrt{3}$

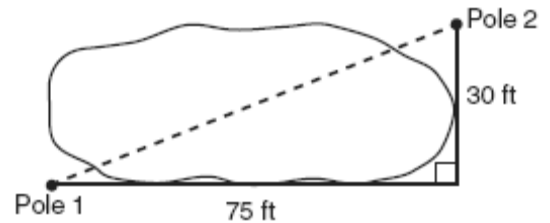

- What is the distance between the two poles, to the nearest foot?
- [A] 69 [B] 45 [C] 81 [D] 105

120. fall0711ia, P.I. A.A.45

Tanya runs diagonally across a rectangular field that has a length of 40 yards and a width of 30 yards, as shown in the diagram below.

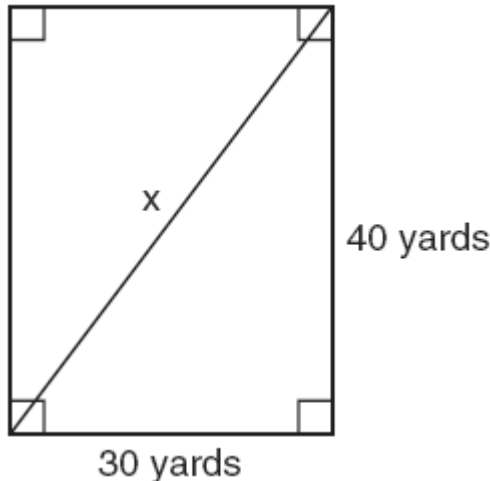

What is the length of the diagonal, in yards, that Tanya runs?

- [A] 80 [B] 60 [C] 70 [D] 50

121. 010023a, P.I. A.A.45

A wall is supported by a brace 10 feet long, as shown in the diagram below. If one end of the brace is placed 6 feet from the base of the wall, how many feet up the wall does the brace reach?

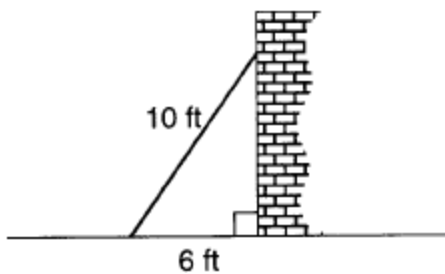

122. 080531a, P.I. A.A.45

The accompanying diagram shows a kite that has been secured to a stake in the ground with a 20-foot string. The kite is located 12 feet from the ground, directly over point X. What is the distance, in feet, between the stake and point X?

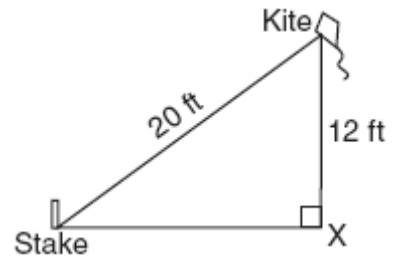

123. 080122a, P.I. A.A.45

How many feet from the base of a house must a 39-foot ladder be placed so that the top of the ladder will reach a point on the house 36 feet from the ground?

124. 060115a, P.I. A.A.45

A woman has a ladder that is 13 feet long. If she sets the base of the ladder on level ground 5 feet from the side of a house, how many feet above the ground will the top of the ladder be when it rests against the house?

- [A] 8 [B] 9 [C] 11 [D] 12

125. 080707a, P.I. A.A.45

A cable 20 feet long connects the top of a flagpole to a point on the ground that is 16 feet from the base of the pole. How tall is the flagpole?

- [A] 8 ft [B] 10 ft [C] 12 ft [D] 26 ft

126. 080633a, P.I. A.A.45

In the accompanying diagram of right triangles ABD and DBC , $AB = 5$, $AD = 4$, and $CD = 1$. Find the length of \overline{BC} , to the nearest tenth.

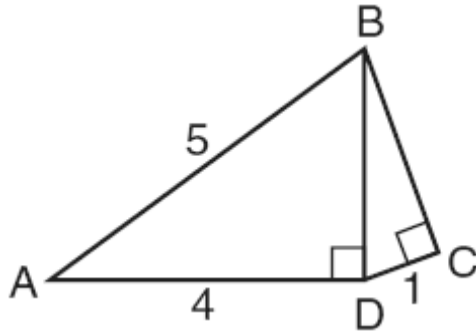

127. 060230a, P.I. G.G.48

In the accompanying diagram, triangle A is similar to triangle B. Find the value of n .

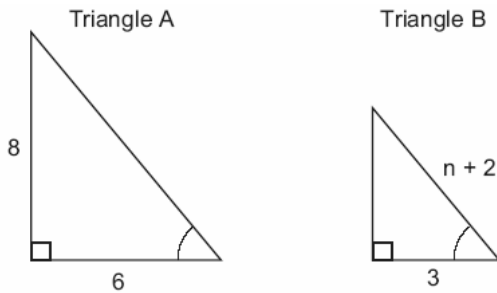

128. 060334a, G.G.48

A straw is placed into a rectangular box that is 3 inches by 4 inches by 8 inches, as shown in the accompanying diagram. If the straw fits exactly into the box diagonally from the bottom left front corner to the top right back corner, how long is the straw, to the nearest tenth of an inch?

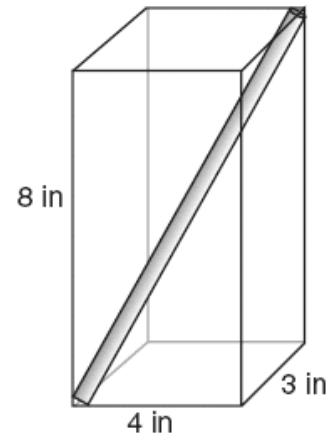

129. 080726b, P.I. G.G.48

The accompanying diagram shows ramp \overline{RA} leading to level platform \overline{AM} , forming an angle of 45° with level ground. If platform \overline{AM} measures 2 feet and is 6 feet above the ground, explain why the exact length of ramp \overline{RA} is $6\sqrt{2}$ feet.

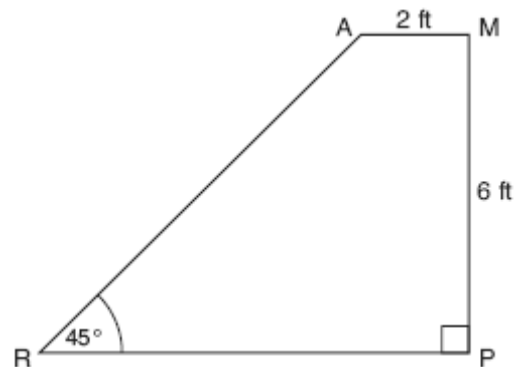

130. 080124b P.I. G.G.48

The accompanying diagram shows a semicircular arch over a street that has a radius of 14 feet. A banner is attached to the arch at points A and B , such that $AE = EB = 5$ feet. How many feet above the ground are these points of attachment for the banner?

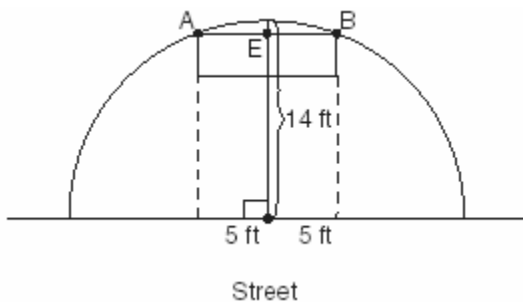

- [3] 4, and appropriate work is shown.
 [2] Appropriate work is shown, but one computational error is made.
 [1] Appropriate work is shown, but two or more computational errors are made.
 or [1] Appropriate work is shown, but one conceptual error is made.
 or [1] 4, but no work is shown.
 [0] A zero response is completely incorrect, irrelevant, or incoherent or is a correct response that was obtained by an obviously incorrect procedure.
- [1] _____
- [2] D
- [3] A
- [4] D
- [5] B
- [6] C
- [7] B
- [2] 6, and appropriate work is shown, such as solving the equation $2x + 3 = 15$ or trial and error with at least three trials and appropriate checks.
 [1] Appropriate work is shown, but one computational error is made.
 or [1] Appropriate work is shown, but one conceptual error is made.
 or [1] A correct equation is written, but no further correct work is shown.
 or [1] The trial-and-error method is attempted and at least six systematic trials and appropriate checks are shown, but no solution is found.
 or [1] 6, but no work or fewer than three trials and appropriate checks are shown.
 [0] A zero response is completely incorrect, irrelevant or incoherent or is a correct response that was obtained by an obviously incorrect procedure.
- [8] _____
- [4] \$167.50, and appropriate work is shown, such as $350x + (150)(130) = 1.25(62,500)$ or trial and error with at least three trials with appropriate checks.
 [3] Appropriate work is shown, but one computational error is made.
 [2] Appropriate work is shown, but more than one computational error is made.
 or [2] \$167.50, but only one trial with an appropriate check is shown.
 [1] \$167.50, but no work is shown.
 [0] A zero response is completely incorrect, irrelevant, or incoherent or is a correct response that was obtained by an obviously incorrect procedure.
- [9] _____
- [10] A
- [2] 38 and an appropriate method is shown, such as $36.64 - (21 + 6.14) = 9.50$ and $\frac{9.50}{.25} = 38$ or an equation such as $21 + .25c + 6.14 = 36.64$.
 [1] 38 and no work is shown.
 or [1] An appropriate method or equation is shown, but one computational mistake is made.
 or [1] The answer of \$9.50 for local calls is found but is not divided by .25.
 [0] A zero response is completely incorrect, irrelevant, or incoherent or is a correct response that was obtained by an obviously incorrect procedure.
- [11] _____
- [12] A
- [13] C
- [14] D
- [15] B
- [16] C
- [17] C
- [18] B

[2] 5 and appropriate work is shown, such as substituting \$18.11 for p and solving the equation correctly, or trial and error with at least three trials and appropriate checks.
[1] Appropriate work is shown, but one computational error is made.
or [1] Appropriate work is shown, but one conceptual error is made.
or [1] 5, but no work or fewer than three trials with appropriate checks are shown.
[0] A zero response is completely incorrect, irrelevant, or incoherent or is a correct response that was obtained by an obviously incorrect procedure.

[19] _____

[20] C _____

[21] C _____

[2] 4, and appropriate work is shown.
[1] Appropriate work is shown, but one computational error is made.
or [1] Appropriate work is shown, but one conceptual error is made.
or [1] 4, but no work is shown.
[0] A zero response is completely incorrect, irrelevant, or incoherent or is a correct response that was obtained by an obviously incorrect procedure.

[22] _____

[2] 2, and appropriate work is shown.
[1] Appropriate work is shown, but one computational error or one conceptual error is made.
or [1] 2, but no work is shown.
[0] A zero response is completely incorrect, irrelevant, or incoherent or is a correct response that was obtained by an obviously incorrect procedure.

[23] _____

[2] 2.4 and appropriate work is shown.
[1] The student shows correct use of the distributive property to obtain $2x - 6$ or other appropriate algebraic technique.
or [1] 2.4 and no work is shown.
[0] A zero response is completely incorrect, irrelevant, or incoherent or is a correct response that was obtained by an obviously incorrect procedure.

[24] _____

[25] A _____

[26] A _____

[27] B _____

[2] 2.1, and appropriate work is shown.
[1] Appropriate work is shown, but one computational error is made.
or [1] Appropriate work is shown, but one conceptual error is made.
or [1] 2.1, but no work is shown.
[0] A zero response is completely incorrect, irrelevant, or incoherent or is a correct response that was obtained by an obviously incorrect procedure.

[28] _____

[29] A _____

[30] A _____

[2] 10, and appropriate work is shown, such as solving the equation or trial and error with at least three trials and appropriate checks.
[1] Appropriate work is shown, but one computational error is made.
or [1] Appropriate work is shown, but one conceptual error is made.
or [1] The trial-and-error method is attempted and at least six systematic trials and appropriate checks are shown, but no solution is found.
or [1] 10, but no work or fewer than three trials and appropriate checks are shown.
[0] A zero response is completely incorrect, irrelevant, or incoherent or is a correct response that was obtained by an obviously incorrect procedure.

[31] _____

[32] A _____

[33] A _____

[34] A _____

[35] B _____

[36] D _____

[37] A _____

[38] A[39] A[40] A[41] D[42] A[43] C[44] D[45] B[46] B[47] C[48] B[49] D[50] C

a [1] $\frac{S+24}{3}$ or $\frac{S}{3}+8$

b [1] 11.5

or [1] Correct substitution into an incorrect part a is shown, and the answer is given to the nearest tenth of an inch.

a and b

[0] A zero response is completely incorrect, irrelevant, or incoherent or is a correct response that was obtained by an obviously

[51] incorrect procedure.[52] D

[2] $r = \sqrt[3]{\frac{3V}{4\pi}}$ or $r = \left(\frac{3V}{4\pi}\right)^{\frac{1}{3}}$ or an equivalent

answer, and appropriate work is shown.

[1] Appropriate work is shown, but one computational error is made.

or [1] Appropriate work is shown, but one conceptual error is made.

or [1] $\sqrt[3]{\frac{3V}{4\pi}}$ or $\left(\frac{3V}{4\pi}\right)^{\frac{1}{3}}$ or an equivalent answer

is found, and appropriate work is shown, but an equation is not written.

or [1] $r = \sqrt[3]{\frac{3V}{4\pi}}$ or $r = \left(\frac{3V}{4\pi}\right)^{\frac{1}{3}}$ or an equivalent

answer, but no work is shown.

[0] A zero response is completely incorrect, irrelevant, or incoherent or is a correct response that was obtained by an obviously

[53] incorrect procedure.

[2] $v = \frac{\pi l^3}{8}$, and appropriate work is shown.

[1] Appropriate work is shown, but one computational error is made.

[1] Appropriate work is shown, but one conceptual error is made.

[1] $v = \frac{\pi l^3}{8}$, but no work is shown.

[0] A zero response is completely incorrect, irrelevant, or incoherent or is a correct response that was obtained by an obviously

[54] incorrect procedure.[55] A[56] D

[2] 18 and correct substitution, $F = \frac{9}{5}(-8) +$

32, is shown.

[1] A correct substitution method is shown, but one computational error is made.

or [1] The answer is not rounded to the nearest integer, such as 17.6 or 17 .

or [1] The student substitutes -8 for F , but then solves appropriately for C .

or [1] The student substitutes +8 for C , but then solves appropriately for F .

or [1] 18 but no work is shown.

[0] A zero response is completely incorrect, irrelevant, or incoherent or is a correct response that was obtained by an obviously

[57] incorrect procedure.

[2] 50, and appropriate work is shown, such as solving the equation $10 = \frac{5}{9}(F - 32)$.

[1] Appropriate work is shown, but one computational error is made.

or [1] Appropriate work is shown, but one conceptual error is made.

or [1] Correct substitution is made into the equation, but no further correct work is shown.

or [1] 50, but no work is shown.

[0] A zero response is completely incorrect, irrelevant, or incoherent or is a correct response that was obtained by an obviously

[58] incorrect procedure.

[3] A correct graph is shown, and an answer between -6° and -2° is found.

[2] A correct formula is used, and -4°C or an equivalent answer is found, but no graph is shown.

or [2] An appropriate graph is shown, and the correct answer is marked, but it is stated incorrectly, such as 5°C instead of -5°C .

or [2] An appropriate graph is shown, but answers outside the given range are found.

or [2] The line graph passes through at least one correct point, and an appropriate answer is found.

[1] The formula is used correctly, but the answer is not in the range, and no graph is shown.

or [1] An answer between -6° and -2° is found, but no graph is shown.

[0] A completely incorrect graph is shown.

or [0] No graph is shown and the formula is used incorrectly.

or [0] A zero response is completely incorrect, irrelevant, or incoherent or is a correct response that was obtained by an

[59] obviously incorrect procedure.

[60] C

[2] $6\frac{2}{3}$ or 6 hr 40 min or $6.\overline{66}$ or an

equivalent answer, and appropriate work is shown.

[1] 400 min, but the answer is not converted into hours.

or [1] Appropriate work is shown, but one computational error is made.

or [1] Appropriate work is shown, but the answer is rounded to the nearest hour.

or [1] 6 or 6 hr 40 min or $6.\overline{66}$ or an equivalent answer, but no work is shown.

[0] A zero response is completely incorrect, irrelevant, or incoherent or is a correct response that was obtained by an obviously

[61] incorrect procedure.

[62] B

[63] B

[64] B[65] B[66] B[67] B

[4] \$52,950, \$35,300, and \$88,250 and an appropriate method is shown, such as $3x + 2x + 5x = \$176,500$.

[3] A correct equation is set up or multiplied by correct fractional values $\frac{3}{10}$, $\frac{2}{10}$, and $\frac{5}{10}$,

but a computational mistake is made, and three appropriate values are found.

or [3] An appropriate method is shown, but not all three values are found.

[2] The equation is set up correctly, but numerous computational mistakes are made, and three appropriate values are found.

or [2] An incorrect equation is shown, but three appropriate values are found.

or [2] An appropriate equation is shown but is solved only for x (17,650).

[1] The equation is set up correctly, but no appropriate values are found.

or [1] Three correct answers are found, and no work is shown.

[0] A zero response is completely incorrect, irrelevant, or incoherent or is a correct response that was obtained by an obviously

[68] incorrect procedure.

[4] \$68,000, and appropriate work is shown.

[3] \$119,000 and \$51,000, and appropriate work is shown, but the answers are not subtracted to find the difference.

or [3] Appropriate work is shown, but one computational error is made.

[2] Appropriate work is shown, but more than one computational error is made.

[1] The value for one share (\$17,000) is found, but no further correct work is shown.

or [1] \$68,000, but no work is shown.

[0] \$17,000 or \$119,000 or \$51,000, and no work is shown.

or [0] A zero response is completely incorrect, irrelevant, or incoherent or is a correct response that was obtained by an

[69] obviously incorrect procedure.

[70] D[71] B[72] B

[2] 70.92, and appropriate work is shown, such as a proportion.

[1] Appropriate work is shown, but one computational or rounding error is made.

or [1] Appropriate work is shown, but one conceptual error is made.

or [1] 70.92, but no work is shown.

[0] A zero response is completely incorrect, irrelevant, or incoherent or is a correct response that was obtained by an obviously

[73] incorrect procedure.

[74] D

[2] 20, and appropriate work is shown, such as $\frac{15}{150} = \frac{2}{x}$.

[1] Appropriate work is shown, but one computational error is made.

or [1] Appropriate work is shown, but one conceptual error is made, such as expressing the answer as $\frac{1}{3}$ hour.

or [1] 20, but no work is shown.

[0] A zero response is completely incorrect, irrelevant, or incoherent or is a correct response that was obtained by an obviously

[75] incorrect procedure.

[3] 4 and an appropriate method is shown, such as calculating A at 6 mph and B at 2 mph through arithmetic, formula, or extending the graph to 60 minutes.

[2] The speeds of 6 and 2 are found but not their difference.

or [2] Their difference is found but not in miles per hour.

[1] Only distances of 4.5 miles and 1.5 miles are found.

or [1] The speeds found are incorrect but then are subtracted appropriately.

or [1] 3 times as fast and no appropriate explanation is given.

or [1] 4 and no appropriate explanation is given.

[0] A zero response is completely incorrect, irrelevant, or incoherent or is a correct response that was obtained by an obviously

[76] incorrect procedure.

[77] D

[78] D

[79] B

[3] 12, and appropriate work is shown, such as finding the rates of both vehicles and then subtracting 48 from 60.

[2] Appropriate work is shown, but one computational error is made.

or [2] The rates of both vehicles are found correctly, and appropriate work is shown, but they are not subtracted.

or [2] The rates of both vehicles are found correctly, and the correct difference is found, but no work is shown.

[1] Appropriate work is shown, but two or more computational errors are made.

or [1] Appropriate work is shown, but one conceptual error is made.

or [1] The rates of both vehicles are found correctly, but no work is shown, and the difference is not found.

or [1] 12, but no work is shown.

[0] A zero response is completely incorrect, irrelevant, or incoherent or is a correct response that was obtained by an obviously

[80] incorrect procedure.

[3] 50, 1.5, and 10, and appropriate work is shown.

[2] Appropriate work is shown, but one computational error is made.

[1] Appropriate work is shown, but one conceptual error is made.

or [1] Appropriate work is shown, but two or more computational errors are made.

or [1] 50, and appropriate work is shown, but no further correct work is shown.

or [1] 1.5, and appropriate work is shown, but no further correct work is shown.

or [1] 10, and appropriate work is shown, but no further correct work is shown.

or [1] 50, 1.5, and 10, but no work is shown.

[0] 50 or 1.5 or 10, but no work is shown.

or [0] A zero response is completely incorrect, irrelevant, or incoherent or is a correct response that was obtained by an

[81] obviously incorrect procedure.

[82] D

[83] A

[84] B

[2] 319, and appropriate work is shown.

[1] A correct proportion is shown, but no solution or an incorrect solution is found.

or [1] An incorrect proportion of equal difficulty is solved appropriately.

or [1] Appropriate work is shown, but one computational error is made.

or [1] 319, but no work is shown.

[0] A zero response is completely incorrect, irrelevant, or incoherent or is a correct response that was obtained by an obviously

[85] incorrect procedure.

[2] 45, and appropriate work is shown, such

as a diagram or $\frac{1.2}{2} = \frac{x}{75}$.

[1] Appropriate work is shown, but no answer or an incorrect answer is found.

or [1] 45, but no work is shown.

[0] A zero response is completely incorrect, irrelevant, or incoherent or is a correct response that was obtained by an obviously

[86] incorrect procedure.

[2] 15, and any equivalent proportion, equation, or fraction conversion is shown,

such as $\frac{12}{16} = \frac{x}{20}$.

[1] An appropriate proportion, equation, or fraction conversion is shown, but one computational or conceptual error is made.

or [1] An incorrect proportion, equation, or fraction conversion is shown, but an appropriate answer is found for the incorrect proportion.

or [1] 15, but no work is shown.

[0] A zero response is completely incorrect, irrelevant, or incoherent or is a correct response that was obtained by an obviously

[87] incorrect procedure.[2] 21 and the student shows an appropriate solution, such as the equation $x + x + 1 + x + 2 = 63$ or trial and error.

[1] Appropriate work is shown, but an incorrect answer is found.

or [1] An incorrect equation is shown, but it is solved appropriately to find an answer, such as $x + x + 2 + x + 4 = 63$.

or [1] 21 but no work is shown.

[0] A zero response is completely incorrect, irrelevant, or incoherent or is a correct response that was obtained by an obviously

[88] incorrect procedure.[89] A[3] 3 hours and an appropriate method or equation is shown, such as $45(x + 1) = 60x$.

[2] An appropriate method is shown, but an incorrect answer is found, such as 4 hours (the truck's time) or 180 miles traveled.

[1] An appropriate equation or method is shown, but no answer is found, such as showing an equation that reflects a one-hour difference in time but it is not solved.

or [1] 3 hours and no work is shown.

[0] A zero response is completely incorrect, irrelevant, or incoherent or is a correct response that was obtained by an obviously

[90] incorrect procedure.[91] D[92] D[2] 5, and appropriate work is shown, such as solving the linear equation $80x + 100x = 900$, using a diagram or proportion or trial and error.

[1] Appropriate work is shown, but one computational error is made.

or [1] 5, but no work is shown.

[0] A zero response is completely incorrect, irrelevant, or incoherent or is a correct response that was obtained by an obviously

[93] incorrect procedure.

[2] Bob, and appropriate work is shown, such as using the distance formula to calculate the two travel times or setting up a proportion.
[1] Appropriate work is shown, but one computational or conceptual error is made, but an appropriate answer is found.
or [1] Appropriate work is shown, but no answer or an incorrect answer is found.
[0] Bob, but no work or inappropriate work is shown.
or [0] A zero response is completely incorrect, irrelevant, or incoherent or is a correct response that was obtained by an obviously incorrect procedure.

[94] A _____

[2] 78.6%, and appropriate work is shown.
[1] Appropriate work is shown, but one computational or rounding error is made.
or [1] Appropriate work is shown, but one conceptual error is made.
or [1] 78.6%, but no work is shown.
[0] A zero response is completely incorrect, irrelevant, incoherent or is a correct response that was obtained by an obviously incorrect procedure.

[95] A _____

[2] 20.7, and appropriate work is shown, such as $\frac{141288}{683748} = \frac{x}{100}$.
[1] Appropriate work is shown, but one computational or rounding error is made.
or [1] Appropriate work is shown, but one conceptual error is made.
or [1] 20.7, but no work is shown.
[0] A zero response is completely incorrect, irrelevant, or incoherent or is a correct response that was obtained by an obviously incorrect procedure.

[96] A _____

[2] 20, and appropriate work is shown, such as $(180 \div 0.9) - 180$.
[1] A partial answer is found, such as 200 students are enrolled, but 180 is not subtracted from the answer.
or [1] An appropriate equation is shown, but one computational error is made, but 180 is subtracted.
or [1] An answer of 18 is found by subtracting 180×0.9 from 180.
or [1] 20, but no work is shown.
[0] A zero response is completely incorrect, irrelevant, or incoherent or is a correct response that was obtained by an obviously incorrect procedure.

[99] A _____

[100] A _____

[2] \$40, and appropriate work is shown.
[1] Appropriate work is shown, but one computational error is made.
or [1] \$40, but no work is shown.
[0] A zero response is completely incorrect, irrelevant, or incoherent or is a correct response that was obtained by an obviously incorrect procedure.

[101] A _____

[3] No, it will not differ and the student shows that both methods lead to \$47.08, such as $\$55 \times .80 = \44 , $\$44 \times 1.07 = \47.08 , $\$55 \times 1.07 = \58.85 , and $\$58.85 \times .80 = \47.08 .
[2] Both ways are computed, one computational mistake is made, and an appropriate answer is found.
or [2] Both ways are computed correctly, but no comparison is found.
[1] At least one way is computed correctly, but no comparison is found.
or [1] Both ways are computed incorrectly, but an appropriate comparison is found.
[0] Both ways are computed incorrectly, and no comparison is found.
or [0] A zero response is completely incorrect, irrelevant, or incoherent or is a correct response that was obtained by an obviously incorrect procedure.

[102] A _____

- [3] \$800, and appropriate work is shown, such as $0.15x + 50 = 170$ or a table of values or trial and error with at least three trials and appropriate checks.
- [2] Appropriate work is shown, but one computational error is made.
or [2] The trial-and-error method is used to find the correct solution, but only two trials and appropriate checks are shown.
- [1] Appropriate work is shown, but two or more computational errors are made.
or [1] Appropriate work is shown, but one conceptual error is made.
or [1] Appropriate work is shown, but the \$50 per day is not included in his pay, resulting in an answer of \$1,133.33.
or [1] The trial-and-error method is attempted and at least six systematic trials and appropriate checks are shown, but no solution is found.
or [1] \$800, but no work or only one trial with an appropriate check is shown.
- [0] A zero response is completely incorrect, irrelevant, or incoherent or is a correct response that was obtained by an obviously incorrect procedure.
- [103] _____
- [2] 44, and appropriate work is shown, such as $0.8(200 - 145)$.
- [1] Appropriate work is shown, but one computational or conceptual error is made.
or [1] 44, but no work is shown.
- [0] A zero response is completely incorrect, irrelevant, or incoherent or is a correct response that was obtained by an obviously incorrect procedure.
- [104] _____
- [105] C
- [2] 42.85714286 or an equivalent answer, and appropriate work is shown.
- [1] Appropriate work is shown, but one computational or rounding error is made.
or [1] An answer of 30 is found by dividing 1.8 by 6.
or [1] An answer of 70 is found by dividing 4.2 by 6.
or [1] 42.85714286 or an equivalent answer, but no work is shown.
- [0] A zero response is completely incorrect, irrelevant, or incoherent or is a correct response that was obtained by an obviously incorrect procedure.
- [106] _____
- [107] A
- [108] B
- [3] 1,095 and 1,209, and appropriate work is shown.
- [2] Appropriate work is shown, but one computational error is made.
or [2] Appropriate work is shown, but a whole-number solution is not found.
or [2] 5% of CD cases is rounded to 58, but 58 is added to or subtracted from 1,152 appropriately.
or [2] Appropriate work is shown, but only one correct solution is found.
- [1] Appropriate work is shown, but more than one computational error is made.
or [1] 5% of CD cases is rounded to 58, but 58 is added to or subtracted from 1,152, but one computational error is made.
or [1] 5% of 1,152 is found, but no further work is shown.
or [1] 1,095 and 1,209, but no work is shown.
- [0] A zero response is completely incorrect, irrelevant, or incoherent or is a correct response that was obtained by an obviously incorrect procedure.
- [109] _____
- [110] B
- [111] C
- [112] A
- [113] B

[114] C

[115] D

[116] B

[117] B

[118] C

[119] C

[120] D

[2] 8 and the use of trigonometry, the Pythagorean theorem, or Pythagorean triple is shown.

[1] The Pythagorean theorem or trigonometry is used, but a computational mistake is made or substitution is incorrect, such as

$$6^2 = 10^2 + x^2.$$

[1] 8 and no work is shown.

[0] A zero response is completely incorrect, irrelevant, or incoherent or is a correct response that was obtained by an obviously

[121] incorrect procedure.

[2] 16, and appropriate work is shown, such as the Pythagorean theorem, the Pythagorean triple, or trigonometry.

[1] Appropriate work is shown, but one computational error is made.

or [1] Appropriate work is shown, but one conceptual error is made, such as using an incorrect trigonometric function.

or [1] 16, but no work is shown.

[0] A zero response is completely incorrect, irrelevant, or incoherent or is a correct response that was obtained by an obviously

[122] incorrect procedure.

[2] 15, and appropriate work is shown, such as using the Pythagorean theorem, Pythagorean triples, or trigonometric functions.

[1] The data are substituted incorrectly, but an appropriate answer is found and is rounded correctly.

or [1] Appropriate work is shown, but one or more computational errors are made.

or [1] 15, but no work is shown.

[0] A zero response is completely incorrect, irrelevant, or incoherent or is a correct response that was obtained by an obviously

[123] incorrect procedure.

[124] D

[125] C

[2] 2.8, and appropriate work is shown, such as $3^2 = 1^2 + (BC)^2$.

[1] Appropriate work is shown, but one computational or rounding error is made.

or [1] Appropriate work is shown, but one conceptual error is made.

or [1] The length of \overline{BD} is found to be 3, but no further correct work is shown.

or [1] 2.8, but no work is shown.

[0] A zero response is completely incorrect, irrelevant, or incoherent or is a correct response that was obtained by an obviously

[126] incorrect procedure.

[3] 3, and appropriate work is shown, such as using a 3:4:5 right triangle, correct proportions, or the Pythagorean theorem with a proportion.

[2] Appropriate work is shown, and the value of the side is determined to be 5, but $n = 3$ is not found.

[1] A correct proportion is set up, but no answer or an incorrect answer is found.

or [1] 3, but no work is shown.

[0] A zero response is completely incorrect, irrelevant, or incoherent or is a correct response that was obtained by an obviously

[127] incorrect procedure.

[4] 9.4, and appropriate work is shown, such as the use of the Pythagorean theorem.
[3] Appropriate work is shown, but one computational or rounding error is made.
[2] Appropriate work is shown, but more than one computational or rounding error is made.
or [2] Appropriate work is shown, but one conceptual error is made.
or [2] An incorrect diagonal of the base is found, but an appropriate solution is found.
or [2] Only the diagonal of the base is found correctly, but appropriate work is shown, such as $3^2 + 4^2 = d^2$ or use of 3–4–5 right triangles.
[1] Appropriate work is shown, but one conceptual error and one computational or rounding error are made.
or [1] The Pythagorean theorem is used to find the length of the straw, but the appropriate legs are not used.
or [1] 9.4, but no work is shown.
[0] A zero response is completely incorrect, irrelevant, or incoherent or is a correct response that was obtained by an obviously incorrect procedure.
[128]

[2] An appropriate explanation is written, such as defining special isosceles right triangles, or appropriate work is shown, such as using legs of six and finding the hypotenuse.
[1] Appropriate work is shown, but one computational error is made.
or [1] Appropriate work is shown, but one conceptual error is made.
[0] A zero response is completely incorrect, irrelevant, or incoherent or is a correct response that was obtained by an obviously incorrect procedure.
[129]

[2] $\sqrt{171}$ or 13 or 13.1 or 13.08 or an equivalent answer, and appropriate work is shown, such as the use of the equation of a circle ($x^2 + y^2 = r^2$) or the Pythagorean theorem.
[1] Appropriate work is shown, but one computational error is made.
or [1] Incorrect analysis is shown, such as $x = 5$ and $y = 14$, but the work is concluded appropriately.
or [1] A correct answer is found, but no work is shown.
[0] A zero response is completely incorrect, irrelevant, or incoherent or is a correct response that was obtained by an obviously incorrect procedure.
[130]
