

# JEFFERSON MATH PROJECT

## REGENTS BY CHAPTER

All 1165 NY Math A & B Regents Exam Questions from  
June 1999 to August 2005 Sorted by Prentice Hall Chapter  
GEOMETRY

[www.jmap.org](http://www.jmap.org)



*Dear Sir*

*I have to acknowledge the receipt of your favor of May 14. in which you mention that you have finished the 6. first books of Euclid, plane trigonometry, surveying & algebra and ask whether I think a further pursuit of that branch of science would be useful to you. there are some propositions in the latter books of Euclid, & some of Archimedes, which are useful, & I have no doubt you have been made acquainted with them. trigonometry, so far as this, is most valuable to every man, there is scarcely a day in which he will not resort to it for some of the purposes of common life. the science of calculation also is indispensable as far as the extraction of the square & cube roots; Algebra as far as the quadratic equation & the use of logarithms are often of value in ordinary cases: but all beyond these is but a luxury; a delicious luxury indeed; but not to be indulged in by one who is to have a profession to follow for his subsistence. in this light I view the conic sections, curves of the higher orders, perhaps even spherical trigonometry, Algebraical operations beyond the 2d dimension, and fluxions.*

Letter from Thomas Jefferson to William G. Munford, Monticello, June 18, 1799.

# TABLE OF CONTENTS

## GEOMETRY

	PRENTICE HALL CHAPTER	NUMBER OF REGENTS QUESTIONS	PAGE
1	Tools of Geometry	11	1
2	Investigating Geometric Figures	28	2
3	Transformations: Shapes in Motion	57	6
4	Triangle Relationships	73	15
5	Measuring in the Plane	52	24
6	Measuring in Space	19	31
7	Reasoning and Parallel Lines	8	34
8	Proving Triangles Congruent	7	36
9	Quadrilaterals	14	37
10	Similarity	15	40
11	Right Triangle Geometry	9	42
12	Chords, Secants, and Tangents	27	43
		320	

# GEOMETRY CHAPTER 1-6

## NY LESSON 3

1. In the accompanying diagram of a construction, what does  $\overline{PC}$  represent?

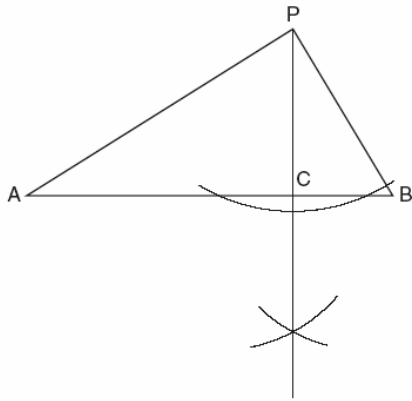

- [A] a median drawn to  $\overline{AB}$   
[B] the bisector of  $\angle APB$   
[C] the perpendicular bisector of  $\overline{AB}$   
[D] an altitude drawn to  $\overline{AB}$
2. Using only a ruler and compass, construct the bisector of angle  $BAC$  in the accompanying diagram.

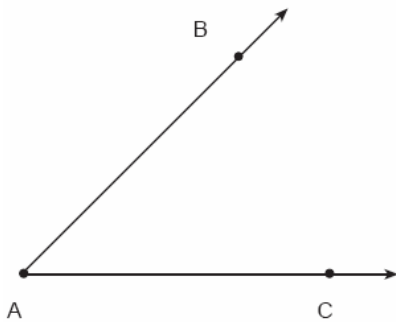

3. Using only a compass and a straightedge, construct the perpendicular bisector of  $\overline{AB}$  and label it  $c$ . [Leave all construction marks.]



4. On the accompanying diagram of  $\triangle ABC$ , use a compass and a straightedge to construct a median from  $A$  to  $\overline{BC}$ .

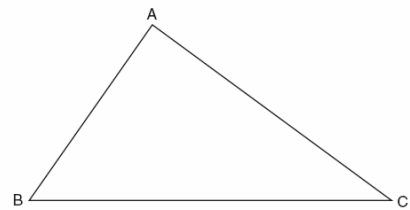

5. Construct a triangle with sides of lengths  $a$ ,  $b$ , and  $c$ , as shown below. Be sure the longest side of your triangle lies on  $\overline{PQ}$  and that point  $P$  is one of the triangle's vertices. [Show all arcs necessary for a valid construction.]

$a$  \_\_\_\_\_  
 $b$  \_\_\_\_\_  
 $c$  \_\_\_\_\_



8. In the accompanying figure, two lines intersect,  $m\angle 3 = 6t + 30$ , and  $m\angle 2 = 8t - 60$ . Find the number of degrees in  $m\angle 4$ .

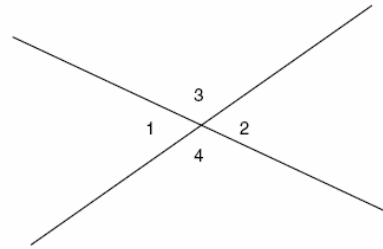

9. If the measure of an angle is represented by  $2x$ , which expression represents the measure of its complement?

- [A]  $90 + 2x$                       [B]  $180 - 2x$   
 [C]  $90 - 2x$                       [D]  $88x$

10. Two angles are complementary. One angle has a measure that is five times the measure of the other angle. What is the measure, in degrees, of the larger angle?

11. The ratio of two supplementary angles is 2:7. What is the measure of the *smaller* angle?

- [A]  $14^\circ$     [B]  $40^\circ$     [C]  $20^\circ$     [D]  $10^\circ$

## GEOMETRY CHAPTER 1-7

### NY LESSON 2

6. In the accompanying diagram,  $\overline{AB}$  and  $\overline{CD}$  intersect at  $E$ . If  $m\angle AEC = 4x - 40$  and  $m\angle BED = x + 50$ , find the number of degrees in  $\angle AEC$ .

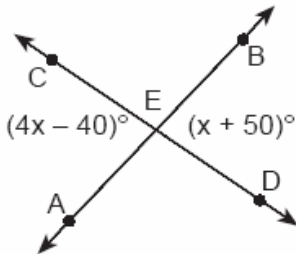

7.  $\overline{AB}$  and  $\overline{CD}$  intersect at point  $E$ ,  $m\angle AEC = 6x + 20$ , and  $m\angle DEB = 10x$ . What is the value of  $x$ ?

- [A]  $21\frac{1}{4}$     [B]  $4\frac{3}{8}$     [C] 5    [D] 10

## GEOMETRY CHAPTER 2-1

12. What is the measure of the largest angle in the accompanying triangle?

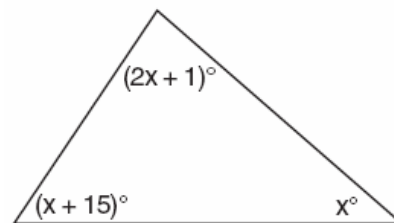

- [A] 46.5    [B] 41    [C] 83    [D] 56

13. In  $\triangle ABC$ , the measure of  $\angle B$  is 21 less than four times the measure of  $\angle A$ , and the measure of  $\angle C$  is 1 more than five times the measure of  $\angle A$ . Find the measure, in degrees, of *each* angle of  $\triangle ABC$ .
14. In the accompanying diagram of  $\triangle BCD$ ,  $\triangle ABC$  is an equilateral triangle and  $AD = AB$ . What is the value of  $x$ , in degrees?

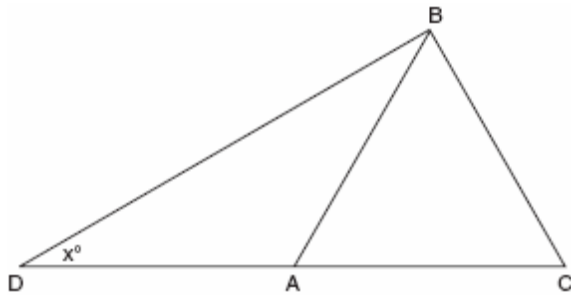

15. In which of the accompanying figures are segments  $XY$  and  $YZ$  perpendicular?

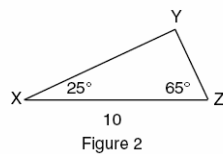
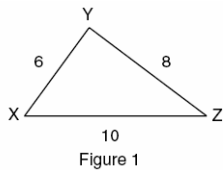

- [A] figure 1, only      [B] figure 2 only  
 [C] both figure 1 and figure 2  
 [D] neither figure 1 nor figure 2
16. In the accompanying diagram,  $\overline{ABCD}$  is a straight line, and angle  $E$  in triangle  $BEC$  is a right angle.

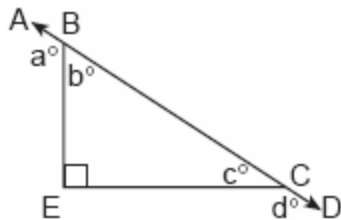

What does  $a^\circ + d^\circ$  equal?

- [A]  $270^\circ$       [B]  $180^\circ$   
 [C]  $135^\circ$       [D]  $160^\circ$

17. In the accompanying diagram of  $\triangle ABC$ ,  $\overline{AB}$  is extended to  $D$ , exterior angle  $CBD$  measures  $145^\circ$ , and  $m\angle C = 75^\circ$ .

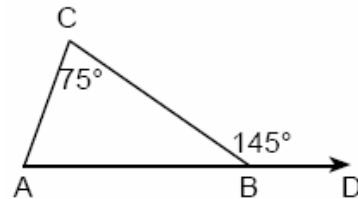

What is  $m\angle CAB$ ?

- [A] 35      [B] 70      [C] 110      [D] 220

18. Triangle  $ABC$ , with side  $\overline{AC}$  extended to  $D$ , is shown in the accompanying diagram. If  $m\angle ABC = 63$  and  $m\angle BCD = 92$ , what is  $m\angle BAC$ ?

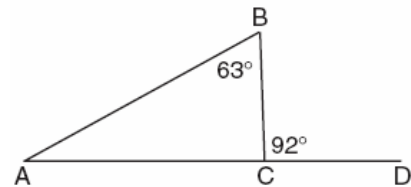

19. In the accompanying diagram of  $\triangle BCD$ ,  $m\angle C = 70$ ,  $m\angle CDE = 130$ , and side  $\overline{BD}$  is extended to  $A$  and to  $E$ . Find  $m\angle CBA$ .

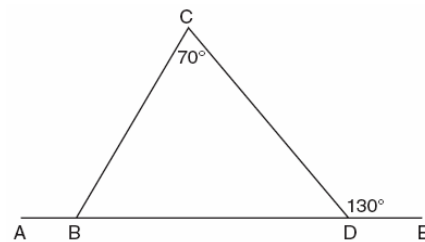

20. Which phrase does *not* describe a triangle?  
 [A] acute scalene      [B] isosceles right  
 [C] equilateral equiangular      [D] obtuse right
21. In right triangle  $ABC$ ,  $m\angle C = 3y - 10$ ,  $m\angle B = y + 40$ , and  $m\angle A = 90$ . What type of right triangle is triangle  $ABC$ ?  
 [A] isosceles      [B] scalene  
 [C] equilateral      [D] obtuse

## GEOMETRY CHAPTER 2-2

22. What is the sum, in degrees, of the measures of the interior angles of a stop sign, which is in the shape of an octagon?
- [A] 1,880                      [B] 1,440  
[C] 1,080                      [D] 360
23. The sum of the measures of the interior angles of an octagon is
- [A]  $360^\circ$                       [B]  $1,080^\circ$   
[C]  $540^\circ$                       [D]  $180^\circ$
24. What is the sum, in degrees, of the measures of the interior angles of a pentagon?
- [A] 900    [B] 540    [C] 180    [D] 360
25. The accompanying figure represents a section of bathroom floor tiles shaped like regular hexagons.



What is the measure of angle  $ABC$ ?

- [A]  $150^\circ$                       [B]  $120^\circ$   
[C]  $90^\circ$                       [D]  $60^\circ$
26. What is the measure, in degrees, of each exterior angle of a regular hexagon?
- [A] 120    [B] 45    [C] 60    [D] 135
27. Melissa is walking around the outside of a building that is in the shape of a regular polygon. She determines that the measure of one exterior angle of the building is  $60^\circ$ . How many sides does the building have?
- [A] 6    [B] 12    [C] 9    [D] 3

28. A stop sign in the shape of a regular octagon is resting on a brick wall, as shown in the accompanying diagram.

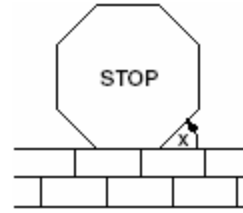

What is the measure of angle  $x$ ?

- [A]  $60^\circ$     [B]  $45^\circ$     [C]  $135^\circ$     [D]  $120^\circ$

## GEOMETRY CHAPTER 2-4

29. Which statement about quadrilaterals is true?
- [A] All quadrilaterals are parallelograms.  
[B] All quadrilaterals have four right angles.  
[C] All quadrilaterals have equal sides.  
[D] All quadrilaterals have four sides.
30. Which statement is *not* always true about a parallelogram?
- [A] The diagonals are congruent.  
[B] The opposite sides are congruent.  
[C] The opposite sides are parallel.  
[D] The opposite angles are congruent.
31. In a certain quadrilateral, two opposite sides are parallel, and the other two opposite sides are *not* congruent. This quadrilateral could be a
- [A] square                      [B] rhombus  
[C] parallelogram              [D] trapezoid

32. Al says, "If  $ABCD$  is a parallelogram, then  $ABCD$  is a rectangle." Sketch a quadrilateral  $ABCD$  that shows that Al's statement is not always true. Your sketch must show the length of each side and the measure of each angle for the quadrilateral you draw.
33. The cross section of an attic is in the shape of an isosceles trapezoid, as shown in the accompanying figure. If the height of the attic is 9 feet,  $BC = 12$  feet, and  $AD = 28$  feet, find the length of  $\overline{AB}$  to the nearest foot.

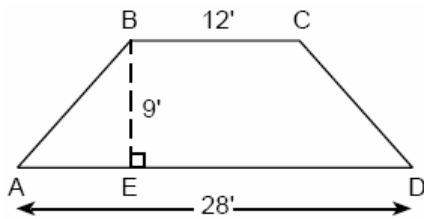

## GEOMETRY CHAPTER 2-5

34. The accompanying circle graph shows how the Marino family spends its income each month.

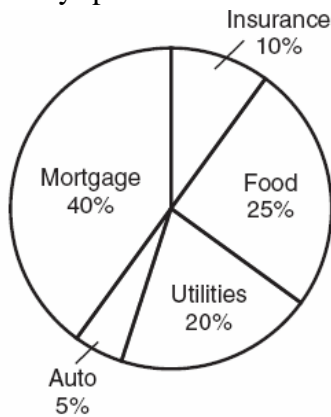

What is the measure, in degrees, of the central angle that represents the percentage of income spent on food?

- [A] 90    [B] 360    [C] 25    [D] 50

35. Mr. Smith's class voted on their favorite ice cream flavors, and the results are shown in the accompanying diagram. If there are 20 students in Mr. Smith's class, how many students chose coffee ice cream as their favorite flavor?

Favorite Ice Cream Flavors

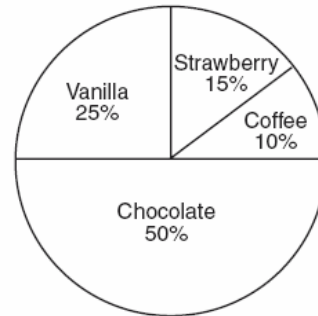

36. The accompanying circle graph shows the favorite colors of the 300 students in the ninth grade. How many students chose red as their favorite color?

Favorite Colors

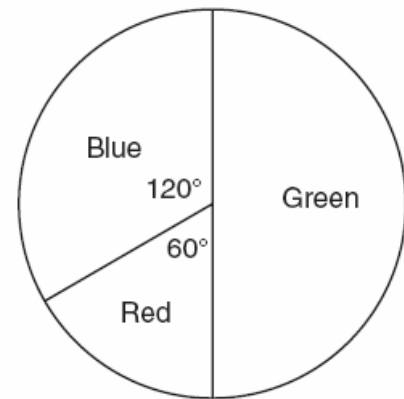

37. In a recent poll, 600 people were asked whether they liked Chinese food. A circle graph was constructed to show the results. The central angles for two of the three sectors are shown in the accompanying diagram. How many people had no opinion?

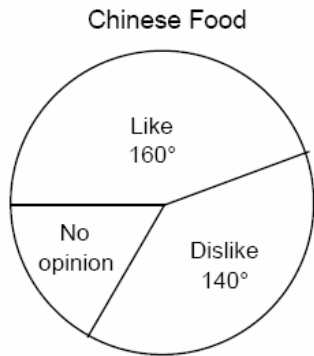

38. In a class of 24 students, 10 have brown hair, 8 have black hair, 4 have blond hair, and 2 have red hair. On the accompanying diagram, construct a circle graph to show the students' hair color.

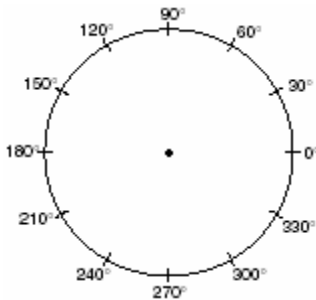

39. Nine hundred students were asked whether they thought their school should have a dress code. A circle graph was constructed to show the results. The central angles for two of the three sectors are shown in the accompanying diagram. What is the number of students who felt that the school should have no dress code?



## GEOMETRY CHAPTER 3

40. In the accompanying diagram, which transformation changes the solid-line parabola to the dotted-line parabola?

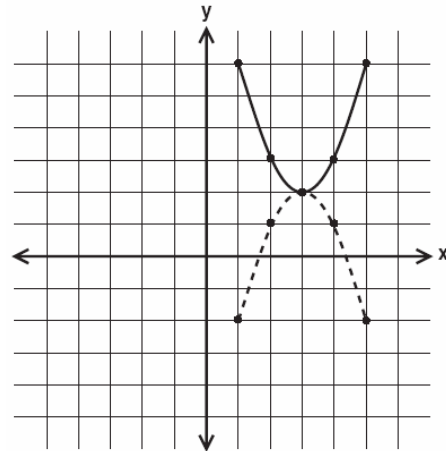

- [A] rotation, only      [B] translation  
 [C] line reflection, only  
 [D] line reflection or rotation
41. Which transformation does *not* always produce an image that is congruent to the original figure?  
 [A] dilation      [B] translation  
 [C] reflection      [D] rotation
42. In the accompanying diagram,  $\triangle ABC$  is similar to but not congruent to  $\triangle A'B'C'$ . Which transformation is represented by  $\triangle A'B'C'$ ?

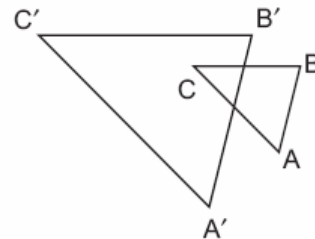

- [A] reflection      [B] dilation  
 [C] rotation      [D] translation



43. The transformation of  $\triangle ABC$  to  $\triangle AB'C'$  is shown in the accompanying diagram.

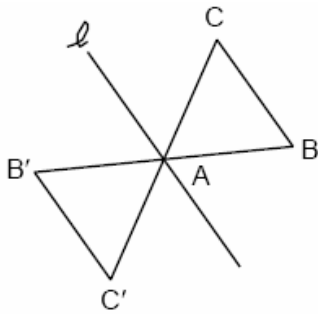

This transformation is an example of a

- [A] translation  
 [B] line reflection in point  $\ell$   
 [C] rotation about point A      [D] dilation
44. The accompanying diagram shows a transformation.

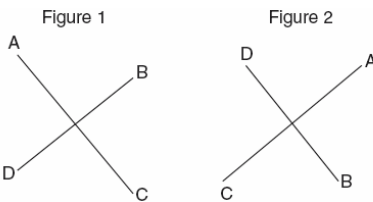

Which transformation performed on figure 1 resulted in figure 2?

- [A] reflection                      [B] translation  
 [C] dilation                        [D] rotation

45. Which type of transformation is illustrated in the accompanying diagram?

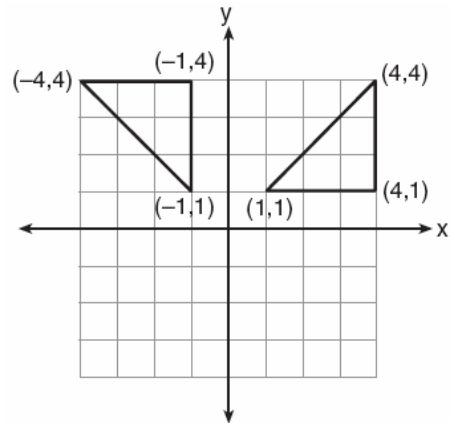

- [A] dilation                      [B] rotation  
 [C] reflection                    [D] translation

46. A picture held by a magnet to a refrigerator slides to the bottom of the refrigerator, as shown in the accompanying diagram.

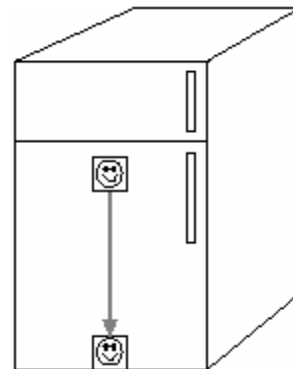

This change of position is an example of a

- [A] reflection                      [B] rotation  
 [C] translation                    [D] dilation

47. As shown in the accompanying diagram, the star in position 1 on a computer screen transforms to the star in position 2.

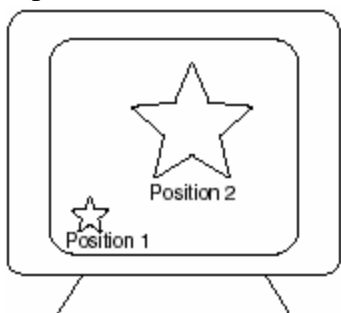

This transformation is best described as a

- [A] line reflection      [B] rotation  
[C] dilation              [D] translation

## GEOMETRY CHAPTER 3-1

48. Which transformation is *not* an isometry?  
[A]  $r_{y=x}$     [B]  $T_{3,6}$     [C]  $R_{0,90^\circ}$     [D]  $D_2$
49. Which transformation is *not* an isometry?  
[A] rotation              [B] line reflection  
[C] dilation              [D] translation
50. Which transformation is a direct isometry?  
[A]  $T_{2,5}$     [B]  $D_2$     [C]  $r_{y-axis}$     [D]  $D_{-2}$
51. Which transformation is an opposite isometry?  
[A] rotation of  $90^\circ$       [B] line reflection  
[C] dilation              [D] translation
52. Which transformation is an example of an opposite isometry?  
[A]  $(x,y) \rightarrow (y,-x)$       [B]  $(x,y) \rightarrow (3x,3y)$   
[C]  $(x,y) \rightarrow (x+3,y-6)$   
[D]  $(x,y) \rightarrow (y,x)$

53. Which transformation does *not* preserve orientation?  
[A] dilation      [B] translation  
[C] reflection in the  $y$ -axis      [D] rotation
54. If  $x = -3$  and  $y = 2$ , which point on the accompanying graph represents  $(-x, -y)$ ?

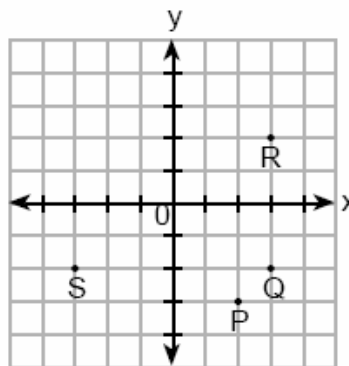

- [A] P      [B] Q      [C] R      [D] S
55. What is the image of point  $(-3, -1)$  under a reflection in the origin?  
[A] (1, 3)              [B] (3, 1)  
[C] (-1, -3)              [D] (-3, 1)
56. When the point  $(2, -5)$  is reflected in the  $x$ -axis, what are the coordinates of its image?  
[A] (5, 2)              [B] (-5, 2)  
[C] (2, 5)              [D] (-2, 5)

57. Triangle  $SUN$  has coordinates  $S(0,6)$ ,  $U(3,5)$ , and  $N(3,0)$ . On the accompanying grid, draw and label  $\triangle SUN$ . Then, graph and state the coordinates of  $\triangle S'U'N'$ , the image of  $\triangle SUN$  after a reflection in the  $y$ -axis.

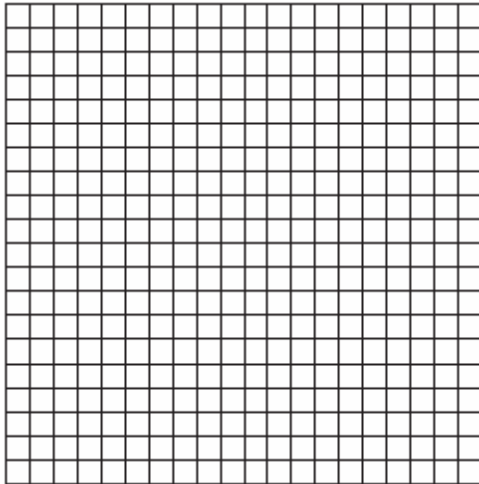

58. The coordinates of the endpoints of  $\overline{AB}$  are  $A(0,2)$  and  $B(4,6)$ . Graph and state the coordinates of  $A'$  and  $B'$ , the images of  $A$  and  $B$  after  $\overline{AB}$  is reflected in the  $x$ -axis.

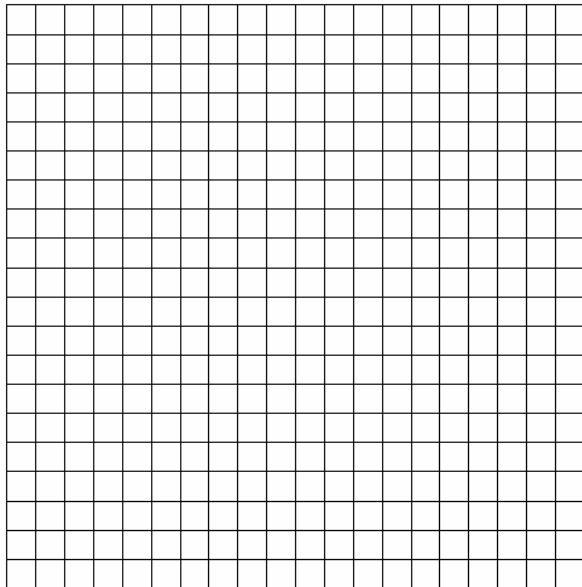

59. On the accompanying set of axes, draw the reflection of  $ABCD$  in the  $y$ -axis. Label and state the coordinates of the reflected figure.

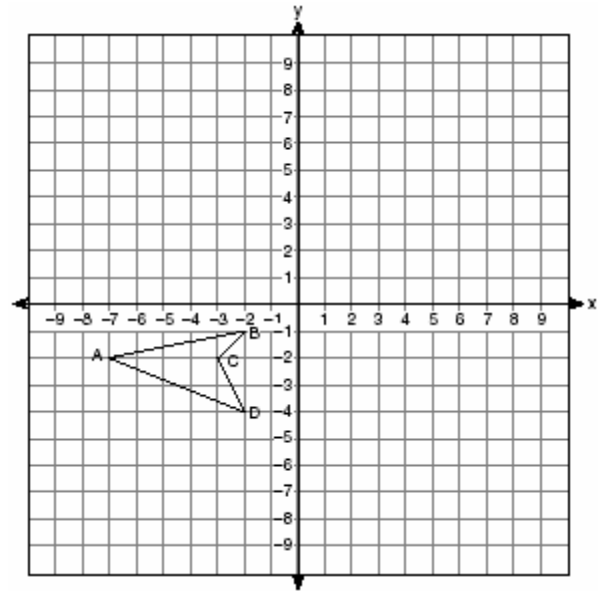

60. What are the coordinates of point  $P$ , the image of point  $(3,-4)$  after a reflection in the line  $y = x$ ?
- [A]  $(-4,3)$                       [B]  $(4,-3)$   
 [C]  $(-3,4)$                       [D]  $(3,4)$
61. In the accompanying diagram of square  $ABCD$ ,  $F$  is the midpoint of  $\overline{AB}$ ,  $G$  is the midpoint of  $\overline{BC}$ ,  $H$  is the midpoint of  $\overline{CD}$ , and  $E$  is the midpoint of  $\overline{DA}$ .

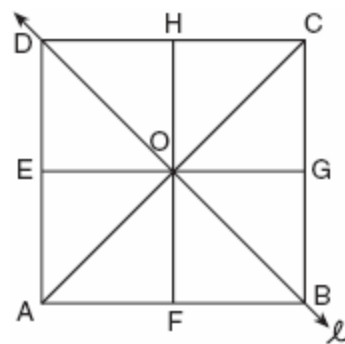

Find the image of  $\triangle EOA$  after it is reflected in line  $l$ .

Is this isometry direct or opposite? Explain your answer.

62. The graph below represents  $f(x)$ .



Which graph best represents  $f(-x)$ ?

- [A] [B]
- [C] [D]

## GEOMETRY CHAPTER 3-2

63. The image of point  $(3,-5)$  under the translation that shifts  $(x,y)$  to  $(x-1, y-3)$  is

- [A]  $(-4,8)$  [B]  $(2,8)$   
 [C]  $(2,-8)$  [D]  $(-3,15)$

64. In the accompanying graph, if point  $P$  has coordinates  $(a,b)$ , which point has coordinates  $(-b,a)$ ?

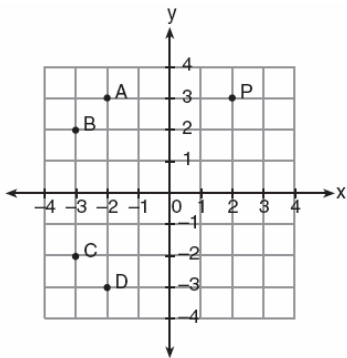

- [A] A [B] B [C] D [D] C

65. If  $x = -2$  and  $y = -1$ , which point on the accompanying set of axes represents the translation  $(x, y) \rightarrow (x + 2, y - 3)$ ?

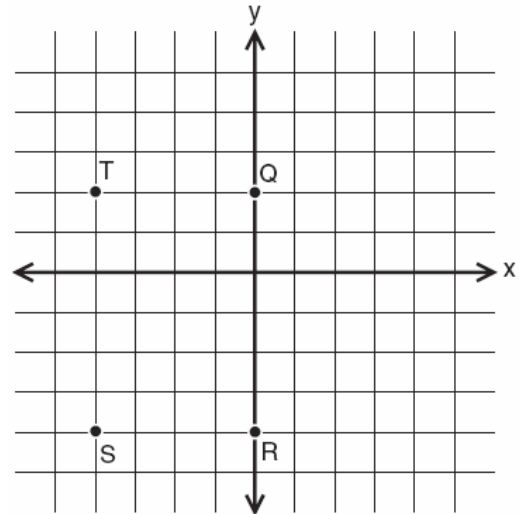

- [A] S [B] Q [C] T [D] R

66. What is the image of point  $(2,5)$  under the translation that shifts  $(x,y)$  to  $(x + 3, y - 2)$ ?

- [A]  $(5,3)$  [B]  $(0,3)$  [C]  $(0,8)$  [D]  $(5,8)$

67. What is the image of  $(x, y)$  after a translation of 3 units right and 7 units down?

- [A]  $(x - 3, y + 7)$  [B]  $(x + 3, y + 7)$   
 [C]  $(x - 3, y - 7)$  [D]  $(x + 3, y - 7)$

68. A translation moves  $P(3,5)$  to  $P'(6,1)$ . What are the coordinates of the image of point  $(-3,-5)$  under the same translation?

- [A]  $(-5,-3)$  [B]  $(0,-9)$   
 [C]  $(-6,-1)$  [D]  $(-6,-9)$

69. What are the coordinates of  $P'$ , the image of  $P(-4, 0)$  under the translation  $(x - 3, y + 6)$ ?

- [A]  $(2,-3)$  [B]  $(-7,6)$   
 [C]  $(1,6)$  [D]  $(7,-6)$

70. The image of the origin under a certain translation is the point  $(2,-6)$ . The image of point  $(-3,-2)$  under the same translation is the point

- [A]  $(-\frac{3}{2}, \frac{1}{3})$                       [B]  $(-1,-8)$   
 [C]  $(-6,12)$                       [D]  $(-5,4)$

71. Two parabolic arches are to be built. The equation of the first arch can be expressed as  $y = -x^2 + 9$ , with a range of  $0 \leq y \leq 9$ , and the second arch is created by the transformation  $T_{7,0}$ . On the accompanying set of axes, graph the equations of the two arches. Graph the line of symmetry formed by the parabola and its transformation and label it with the proper equation.

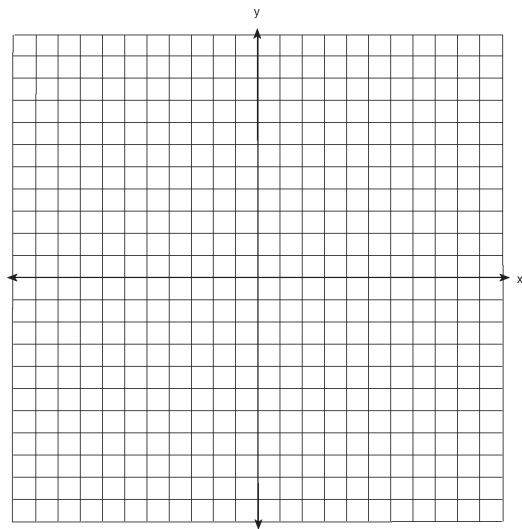

## GEOMETRY CHAPTER 3-3

72. Point  $P'$  is the image of point  $P(-3,4)$  after a translation defined by  $T_{(7,-1)}$ . Which other transformation on  $P$  would also produce  $P'$ ?

- [A]  $r_{y=-x}$                       [B]  $r_{y-axis}$   
 [C]  $R_{90^\circ}$                       [D]  $R_{-90^\circ}$

## GEOMETRY CHAPTER 3-4

73. If the coordinates of point  $A$  are  $(-2,3)$ , what is the image of  $A$  under  $r_{y-axis} \circ D_3$ ?

- [A]  $(6,9)$                       [B]  $(-6,-9)$   
 [C]  $(5,6)$                       [D]  $(9,-6)$

74. What is the image of point  $(1,1)$  under  $r_{x-axis} \circ R_{0,90^\circ}$ ?

- [A]  $(-1,1)$                       [B]  $(1,1)$   
 [C]  $(-1,-1)$                       [D]  $(1,-1)$

75. If  $f(x) = \cos x$ , which graph represents  $f(x)$  under the composition  $r_{y-axis} \circ r_{x-axis}$ ?

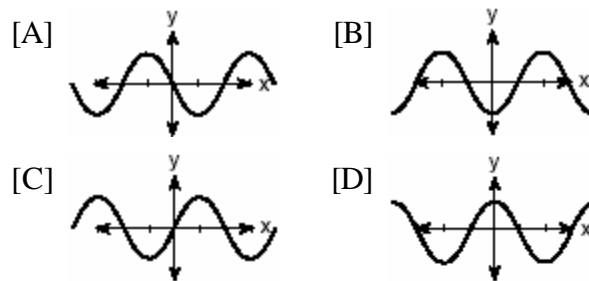

76. The graph of  $f(x)$  is shown in the accompanying diagram.

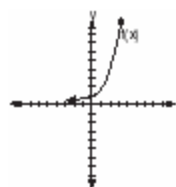

Which graph represents  $f(x)_{r_{x-axis} \circ r_{y-axis}}$ ?

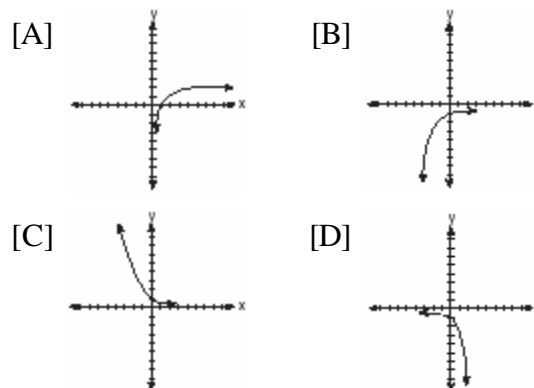

77. The accompanying graph represents the figure  $\square$ .

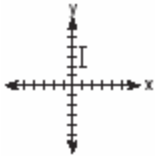

Which graph represents  $\square$  after a transformation defined by  $r_{y=x} \circ R_{90^\circ}$ ?

- [A]
- [B]
- [C]
- [D]

78. a On the accompanying grid, graph the equation  $2y = 2x^2 - 4$  in the interval  $-3 \leq x \leq 3$  and label it  $a$ .

b On the same grid, sketch the image of  $a$  under  $T_{5,-2} \circ r_{x-axis}$  and label it  $b$ .

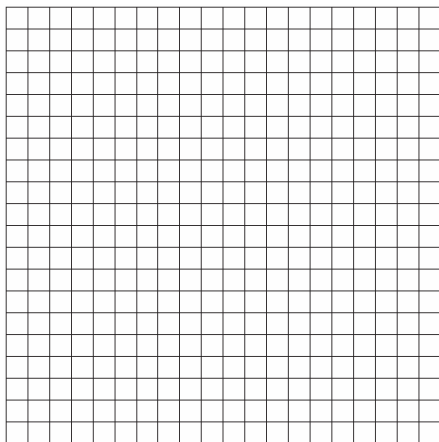

79. Graph and label the following equations,  $a$  and  $b$ , on the accompanying set of coordinate axes.

$$a: y = x^2$$

$$b: y = -(x - 4)^2 + 3$$

Describe the composition of transformations performed on  $a$  to get  $b$ .

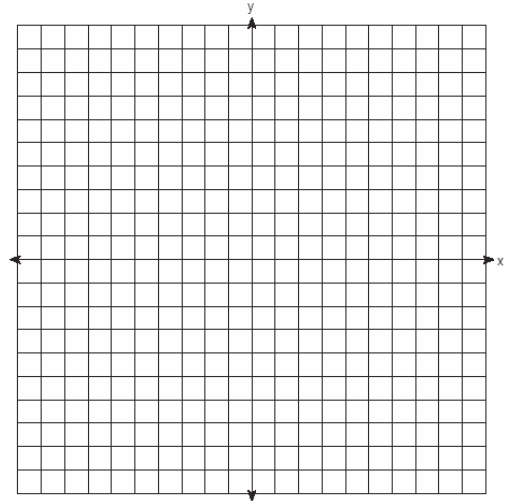

80. On the accompanying grid, graph and label  $\overline{AB}$ , where  $A$  is  $(0,5)$  and  $B$  is  $(2,0)$ . Under the transformation  $r_{x-axis} \circ r_{y-axis}(\overline{AB})$ ,  $A$  maps to  $A''$  and  $B$  maps to  $B''$ . Graph and label  $\overline{A''B''}$ . What single transformation would map  $\overline{AB}$  to  $\overline{A''B''}$ ?

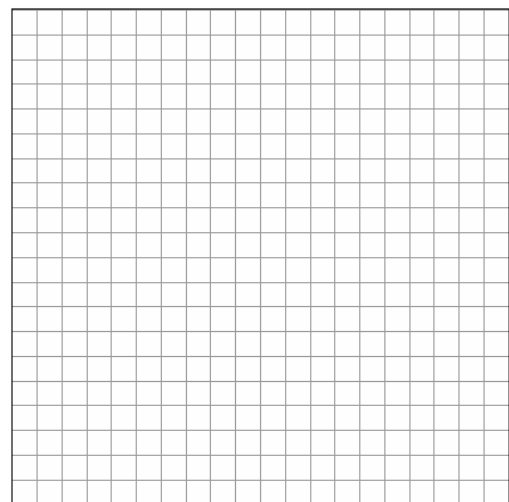

## GEOMETRY CHAPTER 3-5

81. Which graph is symmetric with respect to the  $y$ -axis?

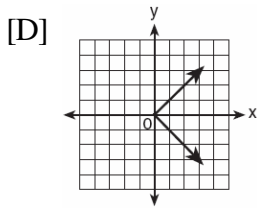
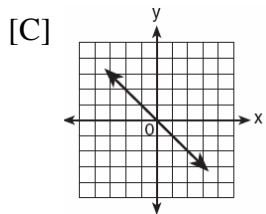
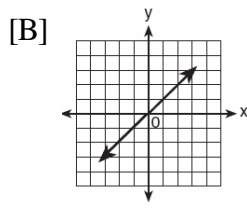
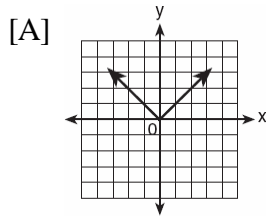

82. Which letter has point symmetry?

[A] B    [B] A    [C] W    [D] H

83. Which letter has point symmetry, but *not* line symmetry?

[A] H    [B] T    [C] S    [D] X

84. Which letter below has point symmetry, but does not have line symmetry?

[A] N    [B] E    [C] H    [D] A

85. Which shape does *not* have rotational symmetry?

[A] circle                      [B] square  
[C] regular pentagon    [D] trapezoid

86. Which geometric figure has one and only one line of symmetry?

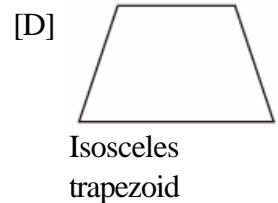
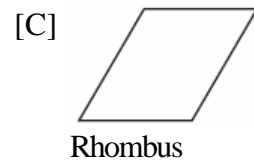
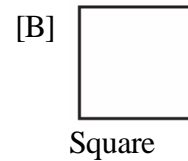
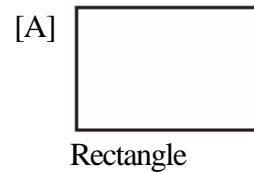

87. Helen is using a capital H in an art design. The H has

[A] two lines of symmetry and only one point of symmetry  
[B] only one line of symmetry  
[C] only two points of symmetry  
[D] two lines of symmetry and two points of symmetry

88. Which diagram shows a dotted line that is *not* a line of symmetry?

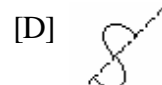
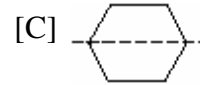
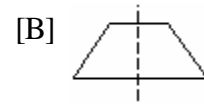
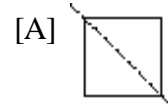

89. Which letter demonstrates line symmetry but *not* point symmetry?

[A] H    [B] T    [C] N    [D] S

90. Draw all the symmetry lines on the accompanying figure.

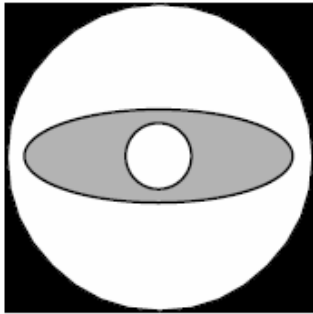

## GEOMETRY CHAPTER 3-7

91. Triangle  $A'B'C'$  is the image of  $\triangle ABC$  under a dilation such that  $A'B' = 3AB$ . Triangles  $ABC$  and  $A'B'C'$  are
- [A] congruent but not similar  
 [B] similar but not congruent  
 [C] neither congruent nor similar  
 [D] both congruent and similar
92. On the accompanying set of axes, graph  $\triangle ABC$  with coordinates  $A(-1,2)$ ,  $B(0,6)$ , and  $C(5,4)$ . Then graph  $\triangle A'B'C'$ , the image of  $\triangle ABC$  after a dilation of 2.

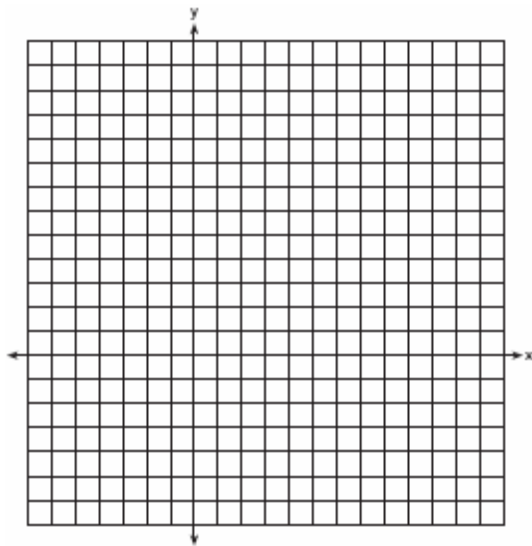

93. The coordinates of the endpoints of  $\overline{AB}$  are  $A(2,6)$  and  $B(4,2)$ . Is the image  $\overline{A''B''}$  the same if it is reflected in the  $x$ -axis, then dilated by  $\frac{1}{2}$  as the image is if it is dilated by  $\frac{1}{2}$ , then reflected in the  $x$ -axis? Justify your answer.

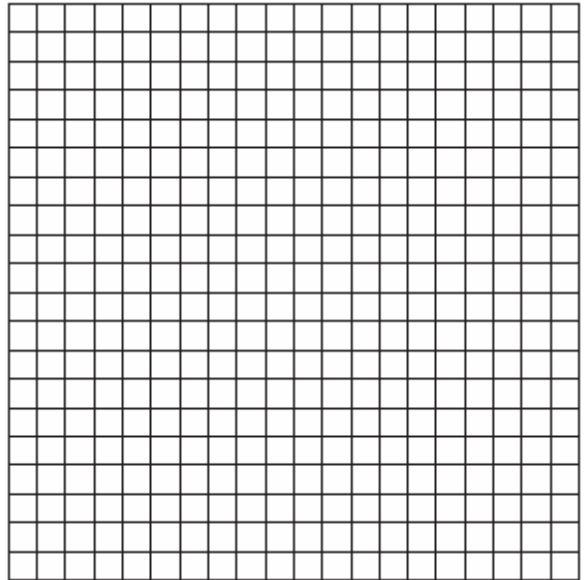

94. In which quadrant would the image of point  $(5,-3)$  fall after a dilation using a factor of  $-3$ ?
- [A] II      [B] III      [C] IV      [D] I



95. In the accompanying graph, the shaded region represents set  $A$  of all points  $(x, y)$  such that  $x^2 + y^2 \leq 1$ . The transformation  $T$  maps point  $(x, y)$  to point  $(2x, 4y)$ .

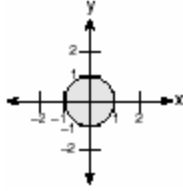

Which graph shows the mapping of set  $A$  by the transformation  $T$ ?

[A]

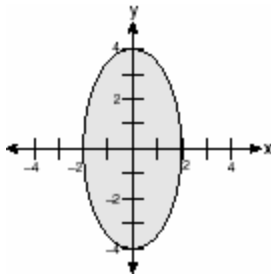

[B]

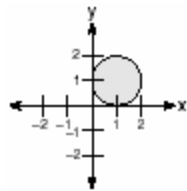

[C]

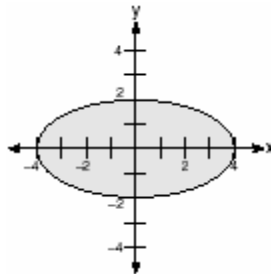

[D]

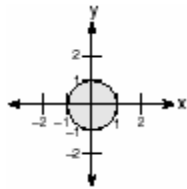

96. The graph of the function  $g(x)$  is shown on the accompanying set of axes. On the same set of axes, sketch the image of  $g(x)$  under the transformation  $D_2$ .

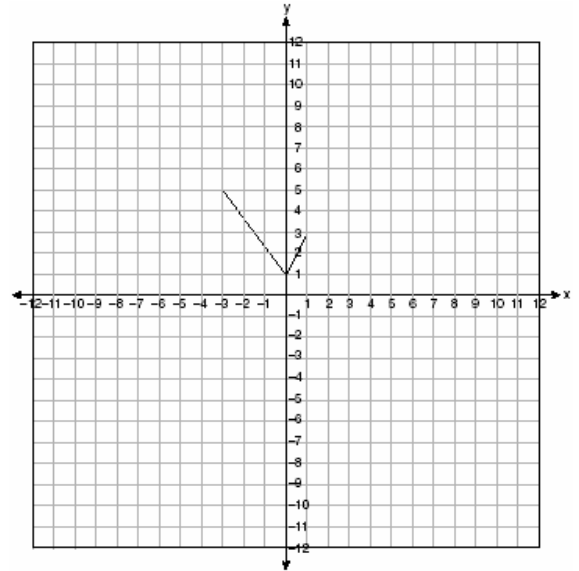

## GEOMETRY CHAPTER 4-1

97. What is the smallest integer greater than 1 that is both the square of an integer and the cube of an integer?
- [A] 64    [B] 9    [C] 8    [D] 36
98. Stan was trying to guess Melanie's age. She told him her age was an even number and a multiple of three. What could be Melanie's age?
- [A] 12    [B] 16    [C] 15    [D] 10
99. Seth is thinking of a number between 20 and 30. The number is prime and not more than 2 away from a perfect square. What is the number?

100. Frank, George, and Hernando are a plumber, a cabinet maker, and an electrician, though not necessarily in that order. Each can do all work appropriate to his own field, but no work in other fields. Frank was not able to install a new electric line in his home. Hernando was not able to make cabinets. George is also a building contractor who hired one of the other people to do his electrical work. Which statement must be true?
- [A] Frank is an electrician.  
[B] Frank is a plumber.  
[C] Hernando is an electrician.  
[D] George is a cabinet maker.
101. John, Dan, Karen, and Beth went to a costume ball. They chose to go as Anthony and Cleopatra, and Romeo and Juliet. John got the costumes for Romeo and Cleopatra, but not his own costume. Dan saw the costumes for Juliet and himself. Karen went as Anthony. Beth drove two of her friends, who were dressed as Anthony and Cleopatra, to the ball. What costume did John wear?
102. At a school costume party, seven girls wore masks and nine boys did not. If there were 15 boys at the party and 20 students did not wear masks, what was the total number of students at the party?
- [A] 30    [B] 42    [C] 33    [D] 35
103. Mary says, "The number I am thinking of is divisible by 2 or it is divisible by 3." Mary's statement is false if the number she is thinking of is
- [A] 6    [B] 15    [C] 8    [D] 11
104. Given the true statements: "Jason goes shopping or he goes to the movies" and "Jason does not go to the movies." Which statement must also be true?
- [A] Jason stays home.  
[B] Jason does not go shopping.  
[C] Jason goes shopping.  
[D] Jason does not go shopping and he does not go to the movies.
105. The statement " $x$  is *not* the square of an integer and  $x$  is a multiple of 3" is true when  $x$  is equal to
- [A] 9    [B] 36    [C] 32    [D] 18
106. The statement "If  $x$  is divisible by 8, then it is divisible by 6" is false if  $x$  equals
- [A] 14    [B] 6    [C] 32    [D] 48
107. The statement "If  $x$  is prime, then it is odd" is false when  $x$  equals
- [A] 2    [B] 4    [C] 3    [D] 1
108. The statement " $x$  is divisible by 5 or  $x$  is divisible by 4" is *false* when  $x$  equals
- [A] 10    [B] 16    [C] 27    [D] 20
109. Given the true statement "John is not handsome" and the false statement "John is handsome or smart." Determine the truth value for the statement "John is smart."
110. Bob and Ray are describing the same number. Bob says, "The number is a positive even integer less than or equal to 20." Ray says, "The number is divisible by 4." If Bob's statement is true and Ray's statement is false, what are all the possible numbers?

111. Mark says, "The number I see is odd." Jan says, "That same number is prime." The teacher says, "Mark is correct or Jan is correct." Some integers would make the teacher's statement true while other integers would make it false. Give and explain one example of when the teacher's statement is true. Give and explain one example of when the teacher's statement is false.
112. What is the contrapositive of the statement "If I study, then I pass the test"?
- [A] I pass the test if I study.  
[B] If I do not study, then I do not pass the test.  
[C] If I do not pass the test, then I do not study.  
[D] If I pass the test, then I study.
113. Which statement is logically equivalent to "If it is Saturday, then I am not in school"?
- [A] If I am in school, then it is not Saturday.  
[B] If I am not in school, then it is Saturday.  
[C] If it is not Saturday, then I am in school.  
[D] If it is Saturday, then I am in school.
114. Which statement is logically equivalent to "If I did not eat, then I am hungry"?
- [A] If I did not eat, then I am not hungry.  
[B] If I am hungry, then I did eat.  
[C] If I am not hungry, then I did not eat.  
[D] If I am not hungry, then I did eat.
115. Which statement is logically equivalent to "If I eat, then I live"?
- [A] If I live, then I eat.  
[B] If I do not live, then I do not eat.  
[C] If I eat, then I do not live.  
[D] I live if and only if I eat.
116. Which statement is logically equivalent to "If a triangle is an isosceles triangle, then it has two congruent sides"?
- [A] If a triangle is an isosceles triangle, then it does not have two congruent sides.  
[B] If a triangle is not an isosceles triangle, then it has two congruent sides.  
[C] If a triangle does not have two congruent sides, then it is not an isosceles triangle.  
[D] If a triangle does not have two congruent sides, then it is an isosceles triangle.
117. Which statement is logically equivalent to "If the team has a good pitcher, then the team has a good season"?
- [A] If the team does not have a good pitcher, then the team does not have a good season.  
[B] The team has a good pitcher and the team does not have a good season.  
[C] If the team does not have a good season, then the team does not have a good pitcher.  
[D] If the team has a good season, then the team has a good pitcher.
118. Given the true statement: "If a person is eligible to vote, then that person is a citizen." Which statement must also be true?
- [A] Marie is not eligible to vote; therefore, she is not a citizen.  
[B] Kayla is not a citizen; therefore, she is not eligible to vote.  
[C] Juan is a citizen; therefore, he is eligible to vote.  
[D] Morgan has never voted; therefore, he is not a citizen.

119. Which statement is logically equivalent to the statement "If you are an elephant, then you do not forget"?
- [A] If you are an elephant, then you forget.  
[B] If you forget, then you are not an elephant.  
[C] If you do not forget, then you are an elephant.  
[D] If you do not forget, then you are not an elephant.
120. Which statement is the converse of "If the sum of two angles is  $180^\circ$ , then the angles are supplementary"?
- [A] If two angles are not supplementary, then their sum is not  $180^\circ$ .  
[B] If the sum of two angles is not  $180^\circ$ , then the angles are supplementary.  
[C] If two angles are supplementary, then their sum is  $180^\circ$ .  
[D] If the sum of two angles is not  $180^\circ$ , then the angles are not supplementary.
121. What is the converse of the statement "If it is sunny, I will go swimming"?
- [A] If it is not sunny, I will not go swimming.  
[B] I will go swimming if and only if it is sunny.  
[C] If I go swimming, it is sunny.  
[D] If I do not go swimming, then it is not sunny.
122. Which statement is the converse of "If it is a 300 ZX, then it is a car"?
- [A] If it is not a 300 ZX, then it is not a car.  
[B] If it is a car, then it is a 300 ZX.  
[C] If it is a car, then it is not a 300 ZX.  
[D] If it is not a car, then it is not a 300 ZX.
123. What is true about the statement "If two angles are right angles, the angles have equal measure " and its converse "If two angles have equal measure then the two angles are right angles"?
- [A] Both the statement and its converse are false.  
[B] The statement is true but its converse is false.  
[C] Both the statement and its converse are true.  
[D] The statement is false but its converse is true.
124. Given the statement: "If two lines are cut by a transversal so that the corresponding angles are congruent, then the lines are parallel." What is true about the statement and its converse?
- [A] The statement is false, but its converse is true.  
[B] The statement and its converse are both false.  
[C] The statement and its converse are both true.  
[D] The statement is true, but its converse is false.

125. Given the statement: "If two sides of a triangle are congruent, then the angles opposite these sides are congruent."
- Given the converse of the statement: "If two angles of a triangle are congruent, then the sides opposite these angles are congruent."
- What is true about this statement and its converse?
- [A] Both the statement and its converse are true.
- [B] Neither the statement nor its converse is true.
- [C] The statement is true but its converse is false.
- [D] The statement is false but its converse is true.
126. What is the converse of the statement "If it is Sunday, then I do not go to school"?
- [A] If I go to school, then it is not Sunday.
- [B] If it is not Sunday, then I go to school.
- [C] If I do not go to school, then it is Sunday.
- [D] If it is not Sunday, then I do not go to school.
127. What is the converse of the statement "If Alicia goes to Albany, then Ben goes to Buffalo"?
- [A] Alicia goes to Albany if and only if Ben goes to Buffalo.
- [B] If Ben does not go to Buffalo, then Alicia does not go to Albany.
- [C] If Alicia does not go to Albany, then Ben does not go to Buffalo.
- [D] If Ben goes to Buffalo, then Alicia goes to Albany.
128. What is the inverse of the statement "If Mike did his homework, then he will pass this test"?
- [A] If Mike passes this test, then he did his homework.
- [B] If Mike did not do his homework, then he will not pass this test.
- [C] If Mike does not pass this test, then he did not do his homework.
- [D] If Mike does not pass this test, then he only did half his homework.
129. What is the inverse of the statement "If Julie works hard, then she succeeds"?
- [A] If Julie works hard, then she does not succeed.
- [B] If Julie does not work hard, then she does not succeed.
- [C] If Julie does not succeed, then she does not work hard.
- [D] If Julie succeeds, then she works hard.
130. What is the inverse of the statement "If it is sunny, I will play baseball"?
- [A] I will play baseball if and only if it is sunny.
- [B] If I play baseball, then it is sunny.
- [C] If I do not play baseball, then it is not sunny.
- [D] If it is not sunny, I will not play baseball.
131. What is the inverse of the statement "If I do not buy a ticket, then I do not go to the concert"?
- [A] If I buy a ticket, then I go to the concert.
- [B] If I buy a ticket, then I do not go to the concert.
- [C] If I go to the concert, then I buy a ticket.
- [D] If I do not go to the concert, then I do not buy a ticket.

## GEOMETRY CHAPTER 4-2

132. In isosceles triangle  $DOG$ , the measure of the vertex angle is three times the measure of one of the base angles. Which statement about  $\triangle DOG$  is true?

- [A]  $\triangle DOG$  is a right triangle.
- [B]  $\triangle DOG$  is an acute triangle.
- [C]  $\triangle DOG$  is an obtuse triangle.
- [D]  $\triangle DOG$  is a scalene triangle.

133. Dylan says that all isosceles triangles are acute triangles. Mary Lou wants to prove that Dylan is *not* correct. Sketch an isosceles triangle that Mary Lou could use to show that Dylan's statement is not true. In your sketch, state the measure of *each* angle of the isosceles triangle.

134. In the accompanying diagram,  $\triangle ABC$  and  $\triangle ABD$  are isosceles triangles with  $m\angle CAB = 50$  and  $m\angle BDA = 55$ . If  $AB=AC$  and  $AB=BD$ , what is  $m\angle CBD$ ?

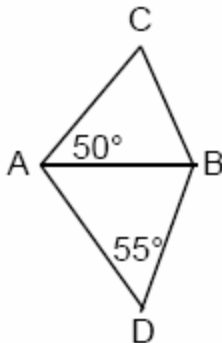

135. Hersch says if a triangle is an obtuse triangle, then it cannot also be an isosceles triangle. Using a diagram, show that Hersch is incorrect, and indicate the measures of all the angles and sides to justify your answer.

136. Vertex angle  $A$  of isosceles triangle  $ABC$  measures  $20^\circ$  more than three times  $m\angle B$ . Find  $m\angle C$ .

137. Tina wants to sew a piece of fabric into a scarf in the shape of an isosceles triangle, as shown in the accompanying diagram.

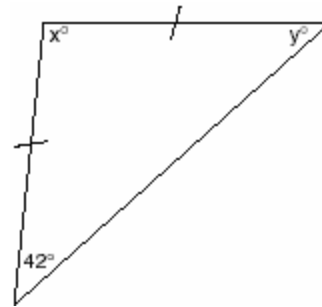

What are the values of  $x$  and  $y$ ?

- [A]  $x = 69$  and  $y = 69$
- [B]  $x = 90$  and  $y = 48$
- [C]  $x = 42$  and  $y = 96$
- [D]  $x = 96$  and  $y = 42$

138. The accompanying diagram shows two cables of equal length supporting a pole. Both cables are 14 meters long, and they are anchored to points in the ground that are 14 meters apart.

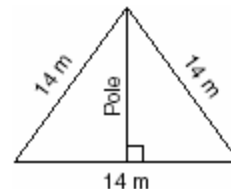

What is the exact height of the pole, in meters?

- [A] 7
- [B]  $7\sqrt{2}$
- [C]  $7\sqrt{3}$
- [D] 14

## GEOMETRY CHAPTER 4-5

139. In the accompanying diagram,  $\triangle ABC$  is *not* isosceles. Prove that if altitude  $\overline{BD}$  were drawn, it would *not* bisect  $\overline{AC}$ .

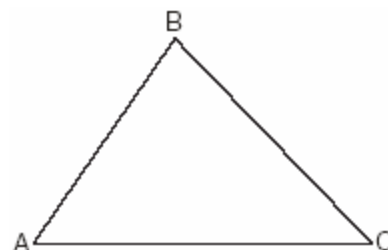

140. Given:  $\triangle ABT$ ,  $\overline{CBTD}$ , and  $\overline{AB} \perp \overline{CD}$

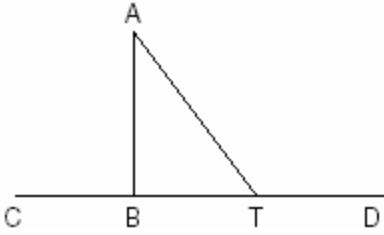

Write an indirect proof to show that  $\overline{AT}$  is *not* perpendicular to  $\overline{CD}$ .

## GEOMETRY CHAPTER 4-6

141. If the lengths of two sides of a triangle are 4 and 10, what could be the length of the third side?  
[A] 14 [B] 16 [C] 8 [D] 6
142. If two sides of a triangle are 1 and 3, the third side may be  
[A] 5 [B] 4 [C] 3 [D] 2
143. Which set can *not* represent the lengths of the sides of a triangle?  
[A] {7,7,12} [B] {8,8,8}  
[C] {4,5,6} [D] {5,5,11}
144. Which set could *not* represent the lengths of the sides of a triangle?  
[A] {3,4,5} [B] {5,10,12}  
[C] {7,9,11} [D] {2,5,9}
145. A plot of land is in the shape of rhombus  $ABCD$  as shown below.
- 
- (Not drawn to scale)
- Which can *not* be the length of diagonal  $AC$ ?  
[A] 24 m [B] 11 m [C] 4 m [D] 18 m
146. The direct distance between city  $A$  and city  $B$  is 200 miles. The direct distance between city  $B$  and city  $C$  is 300 miles. Which could be the direct distance between city  $C$  and city  $A$ ?  
[A] 350 miles [B] 550 miles  
[C] 50 miles [D] 650 miles
147. Sara is building a triangular pen for her pet rabbit. If two of the sides measure 8 feet and 15 feet, the length of the third side could be  
[A] 13 ft [B] 7 ft [C] 23 ft [D] 3 ft
148. José wants to build a triangular pen for his pet rabbit. He has three lengths of boards already cut that measure 7 feet, 8 feet, and 16 feet. Explain why José cannot construct a pen in the shape of a triangle with sides of 7 feet, 8 feet, and 16 feet.
149. A box contains one 2-inch rod, one 3-inch rod, one 4-inch rod, and one 5-inch rod. What is the maximum number of different triangles that can be made using these rods as sides?  
[A] 4 [B] 3 [C] 2 [D] 1

150. An architect commissions a contractor to produce a triangular window. The architect describes the window as  $\triangle ABC$ , where  $m\angle A = 50$ ,  $BC = 10$  inches, and  $AB = 12$  inches. How many distinct triangles can the contractor construct using these dimensions?
- [A] more than 2    [B] 2    [C] 1    [D] 0
151. Sam is designing a triangular piece for a metal sculpture. He tells Martha that two of the sides of the piece are 40 inches and 15 inches, and the angle opposite the 40-inch side measures  $120^\circ$ . Martha decides to sketch the piece that Sam described. How many different triangles can she sketch that match Sam's description?
- [A] 0    [B] 3    [C] 2    [D] 1
152. How many distinct triangles can be formed if  $m\angle A = 30$ , side  $b = 12$ , and side  $a = 8$ ?
- [A] 1    [B] 3    [C] 2    [D] 0
153. A landscape designer is designing a triangular garden with two sides that are 4 feet and 6 feet, respectively. The angle opposite the 4-foot side is  $30^\circ$ . How many distinct triangular gardens can the designer make using these measurements?
154. Main Street and Central Avenue intersect, making an angle measuring  $34^\circ$ . Angela lives at the intersection of the two roads, and Caitlin lives on Central Avenue 10 miles from the intersection. If Leticia lives 7 miles from Caitlin, which conclusion is valid?
- [A] Leticia can live at only one location on Main Street.
- [B] Leticia cannot live on Main Street.
- [C] Leticia can live at one of three locations on Main Street.
- [D] Leticia can live at one of two locations on Main Street.
155. In  $\triangle ABC$ , if  $AC = 12$ ,  $BC = 11$ , and  $m\angle A = 30$ , angle  $C$  could be
- [A] an obtuse angle, only
- [B] an acute angle, only
- [C] a right angle, only
- [D] either an obtuse angle or an acute angle
156. What is the total number of distinct triangles that can be constructed if  $AC = 13$ ,  $BC = 8$ , and  $m\angle A = 36$ ?
- [A] 2    [B] 1    [C] 0    [D] 3

## GEOMETRY CHAPTER 4-7

157. The distance between parallel lines  $\ell$  and  $m$  is 12 units. Point  $A$  is on line  $\ell$ . How many points are equidistant from lines  $\ell$  and  $m$  and 8 units from point  $A$ .
- [A] 4    [B] 1    [C] 3    [D] 2
158. In the coordinate plane, what is the total number of points 5 units from the origin and equidistant from both the  $x$ - and  $y$ -axes?
- [A] 4    [B] 2    [C] 1    [D] 0
159. What is the total number of points equidistant from two intersecting straight roads and also 300 feet from the traffic light at the center of the intersection?
- [A] 4    [B] 0    [C] 2    [D] 1
160. How many points are equidistant from two parallel lines and also equidistant from two points on one of the lines?
- [A] 2    [B] 3    [C] 4    [D] 1



161. In the accompanying diagram, line  $l_1$  is parallel to line  $l_2$ .



Which term describes the locus of all points that are equidistant from line  $l_1$  and  $l_2$ ?

- [A] line                      [B] point  
 [C] circle                  [D] rectangle
162. The locus of points equidistant from two sides of an acute scalene triangle is
- [A] an angle bisector      [B] the third side  
 [C] an altitude            [D] a median
163. If point  $P$  lies on line  $l$ , which diagram represents the locus of points 3 centimeters from point  $P$ ?

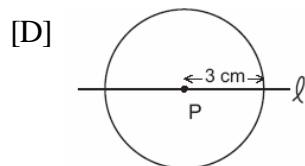
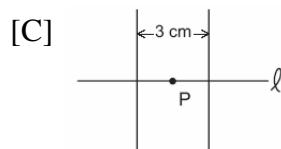
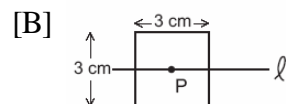
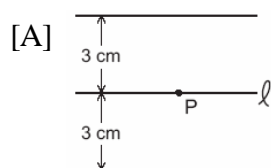

164. Which equation represents the locus of all points 5 units below the  $x$ -axis?
- [A]  $x = 5$                       [B]  $x = -5$   
 [C]  $y = -5$                     [D]  $y = 5$

165. A treasure map shows a treasure hidden in a park near a tree and a statue. The map indicates that the tree and the statue are 10 feet apart. The treasure is buried 7 feet from the base of the tree and also 5 feet from the base of the statue. How many places are possible locations for the treasure to be buried? Draw a diagram of the treasure map, and indicate with an **X** each possible location of the treasure.

166. Maria's backyard has two trees that are 40 feet apart, as shown in the accompanying diagram. She wants to place lampposts so that the posts are 30 feet from both of the trees. Draw a sketch to show where the lampposts could be placed in relation to the trees. How many locations for the lampposts are possible?

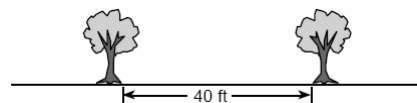

167. Steve has a treasure map, represented in the accompanying diagram, that shows two trees 8 feet apart and a straight fence connecting them. The map states that treasure is buried 3 feet from the fence and equidistant from the two trees.

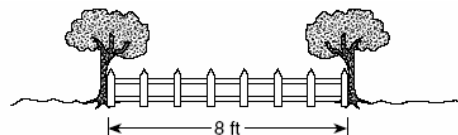

- a Sketch a diagram to show all the places where the treasure could be buried. Clearly indicate in your diagram where the treasure could be buried.  
 b What is the distance between the treasure and one of the trees?

168. A triangular park is formed by the intersection of three streets, Bridge Street, Harbor Place, and College Avenue, as shown in the accompanying diagram. A walkway parallel to Harbor Place goes through the park. A time capsule has been buried in the park in a location that is equidistant from Bridge Street and College Avenue and 5 yards from the walkway. Indicate on the diagram with an **X** *each* possible location where the time capsule could be buried.

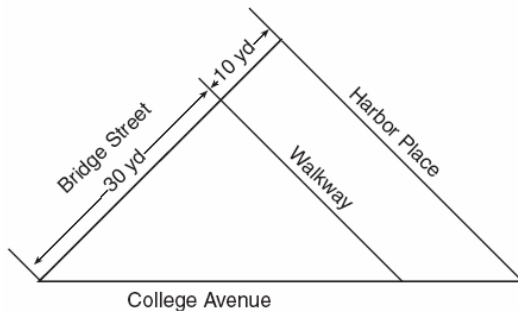

169. Point  $P$  is located on  $\overline{AB}$ .
- a Describe the locus of points that are
- (1) 3 units from  $\overline{AB}$
  - (2) 5 units from point  $P$
- b How many points satisfy both conditions in part a?

## GEOMETRY CHAPTER 5-1

170. The Pentagon building in Washington, D.C., is shaped like a regular pentagon. If the length of one side of the Pentagon is represented by  $n + 2$ , its perimeter would be represented by
- [A]  $5n + 10$                       [B]  $10n$
- [C]  $5n + 2$                         [D]  $n + 10$
171. If the area of a square garden is 48 square feet, what is the length, in feet, of one side of the garden?
- [A]  $12\sqrt{2}$                         [B]  $4\sqrt{6}$
- [C]  $4\sqrt{3}$                             [D]  $16\sqrt{3}$
172. What is the area of a square whose perimeter is represented by  $12x$ ?
- [A]  $6x\sqrt{2}$                         [B]  $9x^2$
- [C]  $12x^2$                             [D]  $144x^2$
173. The length of a side of a square window in Jessica's bedroom is represented by  $2x - 1$ . Which expression represents the area of the window?
- [A]  $4x^2 + 1$                         [B]  $4x^2 - 4x + 1$
- [C]  $4x^2 + 4x - 1$                 [D]  $2x^2 + 1$
174. The accompanying diagram shows a square with side  $y$  inside a square with side  $x$ .

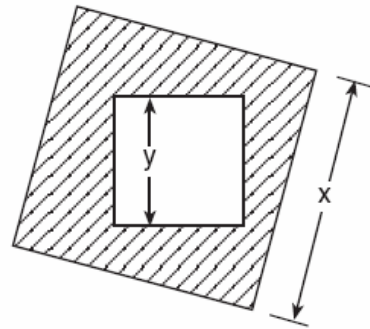

Which expression represents the area of the shaded region?

- [A]  $y^2$                                 [B]  $x^2$
- [C]  $x^2 - y^2$                         [D]  $y^2 - x^2$

175. In the accompanying figure,  $ACDH$  and  $BCEF$  are rectangles,  $AH = 2$ ,  $GH = 3$ ,  $GF = 4$ , and  $FE = 5$ .

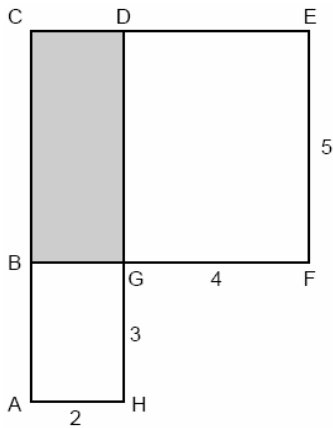

What is the area of  $BCDG$ ?

- [A] 6      [B] 20      [C] 10      [D] 8
176. A farmer has a rectangular field that measures 100 feet by 150 feet. He plans to increase the area of the field by 20%. He will do this by increasing the length and width by the same amount,  $x$ . Which equation represents the area of the new field?
- [A]  $2(100 + x) + 2(150 + x) = 15,000$   
 [B]  $(100 + x)(150 + x) = 15,000$   
 [C]  $(100 + 2x)(150 + x) = 18,000$   
 [D]  $(100 + x)(150 + x) = 18,000$
177. An engineer measured the dimensions for a rectangular site by using a wooden pole of unknown length  $x$ . The length of the rectangular site is 2 pole measures increased by 3 feet, while the width is 1 pole measure decreased by 4 feet. Write an algebraic representation, in terms of  $x$ , for the perimeter of the site.
178. Jack is building a rectangular dog pen that he wishes to enclose. The width of the pen is 2 yards less than the length. If the area of the dog pen is 15 square yards, how many yards of fencing would he need to completely enclose the pen?

179. The area of the rectangular playground enclosure at South School is 500 square meters. The length of the playground is 5 meters longer than the width. Find the dimensions of the playground, in meters. [Only an algebraic solution will be accepted.]
180. Javon's homework is to determine the dimensions of his rectangular backyard. He knows that the length is 10 feet more than the width, and the total area is 144 square feet. Write an equation that Javon could use to solve this problem. Then find the dimensions, in feet, of his backyard.
181. A rectangular park is three blocks longer than it is wide. The area of the park is 40 square blocks. If  $w$  represents the width, write an equation in terms of  $w$  for the area of the park. Find the length and the width of the park.
182. Express both the perimeter and the area of the rectangle shown in the accompanying diagram as polynomials in simplest form.

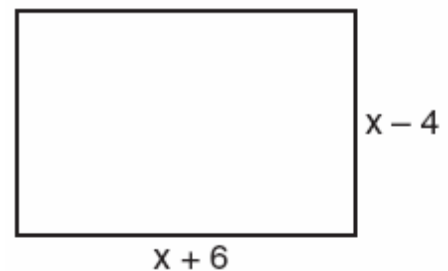

183. Mr. Santana wants to carpet exactly half of his rectangular living room. He knows that the perimeter of the room is 96 feet and that the length of the room is 6 feet longer than the width. How many square feet of carpeting does Mr. Santana need?
184. Kerry is planning a rectangular garden that has dimensions of 4 feet by 6 feet. Kerry wants one-half of the garden to have roses, and she says that the rose plot will have dimensions of 2 feet by 3 feet. Is she correct? Explain.

185. Keesha wants to tile the floor shown in the accompanying diagram. If each tile measures 1 foot by 1 foot and costs \$2.99, what will be the total cost, including an 8% sales tax, for tiling the floor?

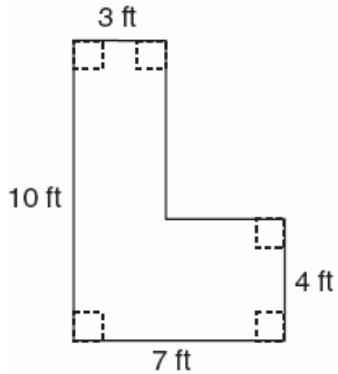

186. In the figure below, the large rectangle,  $ABCD$ , is divided into four smaller rectangles. The area of rectangle  $AEHG = 5x$ , the area of rectangle  $GHFB = 2x^2$ , the area of rectangle  $HJCF = 6x$ , segment  $AG = 5$ , and segment  $AE = x$ .

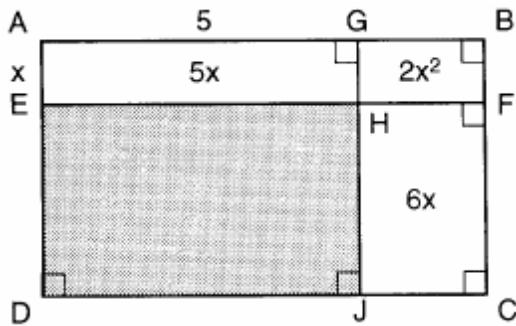

- a Find the area of the shaded region.  
 b Write an expression for the area of the rectangle  $ABCD$  in terms of  $x$ .

187. A rectangular garden is going to be planted in a person's rectangular backyard, as shown in the accompanying diagram. Some dimensions of the backyard and the width of the garden are given. Find the area of the garden to the nearest square foot.

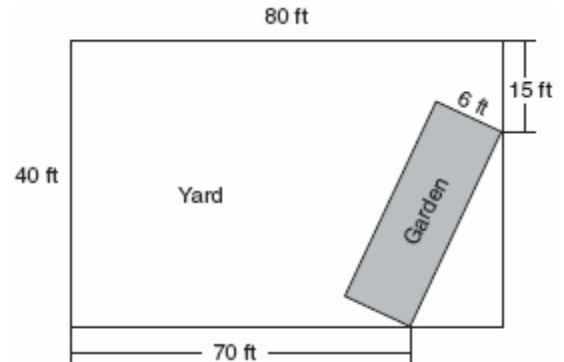

188. Mr. James wanted to plant a garden that would be in the shape of a rectangle. He was given 80 feet of fencing to enclose his garden. He wants the length to be 10 feet more than twice the width. What are the dimensions, in feet, for a rectangular garden that will use exactly 80 feet of fencing?
189. In the accompanying diagram, the perimeter of is equal to the perimeter of square  $ABCD$ . If the sides of the triangle are represented by  $4x + 4$ ,  $5x - 3$ , and 17, and one side of the square is represented by  $3x$ , find the length of a side of the square.

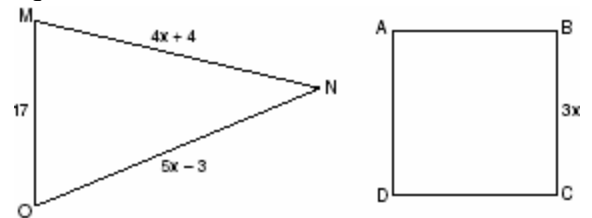

190. A homeowner wants to increase the size of a rectangular deck that now measures 15 feet by 20 feet, but building code laws state that a homeowner cannot have a deck larger than 900 square feet. If the length and the width are to be increased by the same amount, find, to the nearest tenth, the maximum number of feet that the length of the deck may be increased in size legally.

191. Chad had a garden that was in the shape of a rectangle. Its length was twice its width. He decided to make a new garden that was 2 feet longer and 2 feet wider than his first garden. If  $x$  represents the original width of the garden, which expression represents the difference between the area of his new garden and the area of the original garden?

- [A]  $x^2 + 3x + 2$       [B] 8  
 [C]  $6x + 4$       [D]  $2x^2$

192. A small, open-top packing box, similar to a shoebox without a lid, is three times as long as it is wide, and half as high as it is long. Each square inch of the bottom of the box costs \$0.008 to produce, while each square inch of any side costs \$0.003 to produce. Write a function for the cost of the box described above. Using this function, determine the dimensions of a box that would cost \$0.69 to produce.

194. Sean knows the length of the base,  $b$ , and the area,  $A$ , of a triangular window in his bedroom. Which formula could he use to find the height,  $h$ , of this window?

- [A]  $h = \frac{2A}{b}$       [B]  $h = \frac{A}{2b}$   
 [C]  $h = \frac{2A}{b}$       [D]  $h = 2A - b$

195. If the midpoints of the sides of a triangle are connected, the area of the triangle formed is what part of the area of the original triangle?

- [A]  $\frac{3}{8}$       [B]  $\frac{1}{3}$       [C]  $\frac{1}{2}$       [D]  $\frac{1}{4}$

196. On the accompanying set of axes, graph and label the following lines:

$$y = 5$$

$$x = -4$$

$$y = \frac{5}{4}x + 5$$

Calculate the area, in square units, of the triangle formed by the three points of intersection.

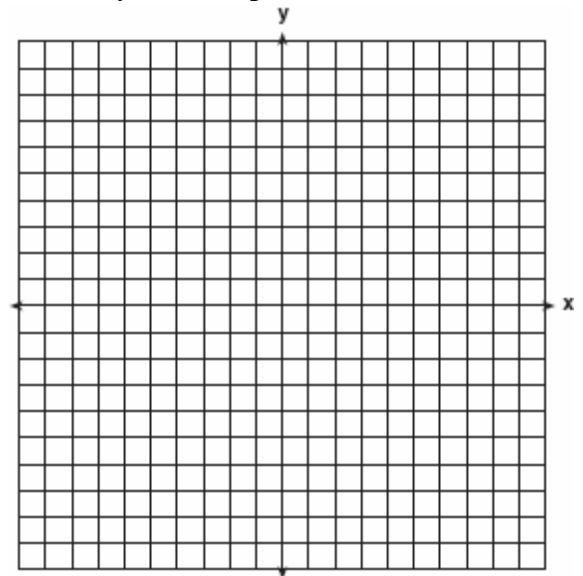

## GEOMETRY CHAPTER 5-2

193. What is the perimeter of an equilateral triangle whose height is  $2\sqrt{3}$ ?

- [A] 6      [B] 12      [C]  $6\sqrt{3}$       [D]  $12\sqrt{3}$

197. Mr. Gonzalez owns a triangular plot of land  $BCD$  with  $DB = 25$  yards and  $BC = 16$  yards. He wishes to purchase the adjacent plot of land in the shape of right triangle  $ABD$ , as shown in the accompanying diagram, with  $AD = 15$  yards. If the purchase is made, what will be the total number of square yards in the area of his plot of land,  $\triangle ACD$ ?

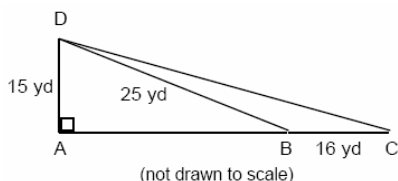

198. The plan of a parcel of land is represented by trapezoid  $ABCD$  in the accompanying diagram. If the area of  $\triangle ABE$  is 600 square feet, find the minimum number of feet of fence needed to completely enclose the entire parcel of land,  $ABCD$ .

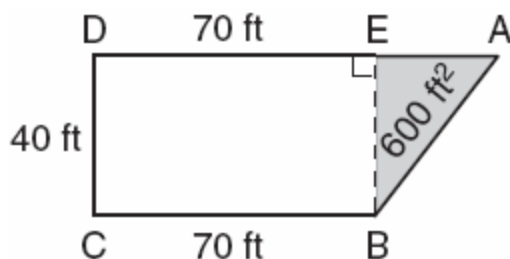

199. The plot of land illustrated in the accompanying diagram has a perimeter of 34 yards. Find the length, in yards, of *each* side of the figure. Could these measures actually represent the measures of the sides of a triangle? Explain your answer.

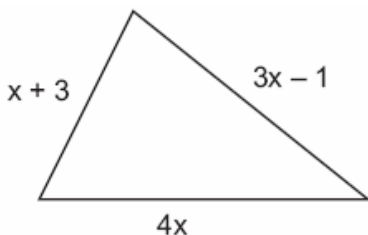

200. On the accompanying grid, draw and label quadrilateral  $ABCD$  with points  $A(1,2)$ ,  $B(6,1)$ ,  $C(7,6)$ , and  $D(3,7)$ . On the same set of axes, plot and label quadrilateral  $A'B'C'D'$ , the reflection of quadrilateral  $ABCD$  in the y-axis. Determine the area, in square units, of quadrilateral  $A'B'C'D'$ .

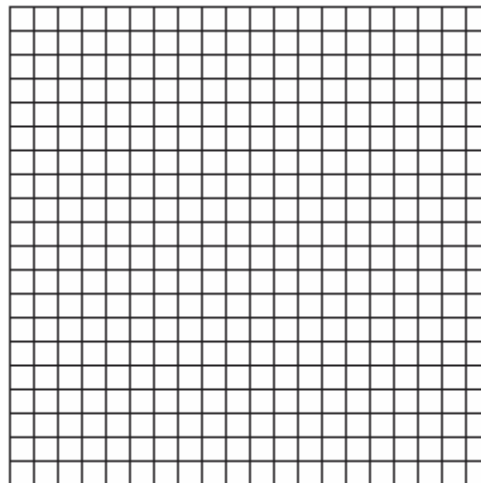

## GEOMETRY CHAPTER 5-4

201. A garden in the shape of an equilateral triangle has sides whose lengths are 10 meters. What is the area of the garden?
- [A]  $25 m^2$                       [B]  $50 m^2$   
 [C]  $25\sqrt{3} m^2$                 [D]  $50\sqrt{3} m^2$

## GEOMETRY CHAPTER 5-6

202. A picnic table in the shape of a regular octagon is shown in the accompanying diagram. If the length of  $\overline{AE}$  is 6 feet, find the length of one side of the table to the *nearest tenth of a foot*, and find the area of the table's surface to the *nearest tenth of a square foot*.

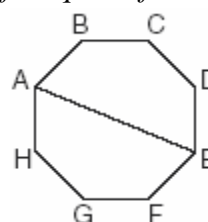

## GEOMETRY CHAPTER 5-7

203. What is the approximate circumference of a circle with radius 3?

- [A] 7.07                      [B] 18.85  
[C] 9.42                      [D] 28.27

204. What is the diameter of a circle whose circumference is 5?

- [A]  $\frac{5}{p^2}$     [B]  $\frac{2.5}{p}$     [C]  $\frac{2.5}{p^2}$     [D]  $\frac{5}{p}$

205. A wheel has a radius of 5 feet. What is the minimum number of *complete* revolutions that the wheel must make to roll at least 1,000 feet?

206. To measure the length of a hiking trail, a worker uses a device with a 2-foot-diameter wheel that counts the number of revolutions the wheel makes. If the device reads 1,100.5 revolutions at the end of the trail, how many miles long is the trail, to the *nearest tenth of a mile*?

207. Every time the pedals go through a  $360^\circ$  rotation on a certain bicycle, the tires rotate three times. If the tires are 24 inches in diameter, what is the minimum number of complete rotations of the pedals needed for the bicycle to travel at least 1 mile?

- [A] 12    [B] 561    [C] 281    [D] 5,280

208. Ileana buys a large circular pizza that is divided into eight equal slices. She measures along the outer edge of the crust from one piece and finds it to be  $5\frac{1}{2}$  inches. What is the diameter of the pizza to the *nearest inch*?

- [A] 14    [B] 4    [C] 8    [D] 7

209. A ball is rolling in a circular path that has a radius of 10 inches, as shown in the accompanying diagram. What distance has the ball rolled when the subtended arc is  $54^\circ$ ? Express your answer to the *nearest hundredth of an inch*.

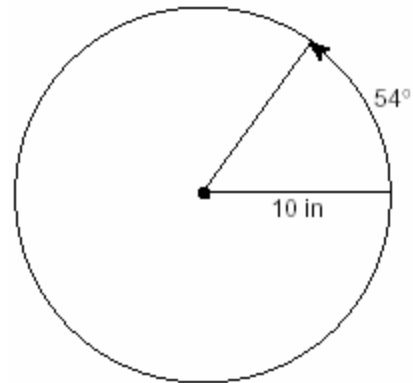

210. Cities *H* and *K* are located on the same line of longitude and the difference in the latitude of these cities is  $9^\circ$ , as shown in the accompanying diagram. If Earth's radius is 3,954 miles, how many miles north of city *K* is city *H* along arc *HK*? Round your answer to the *nearest tenth of a mile*.

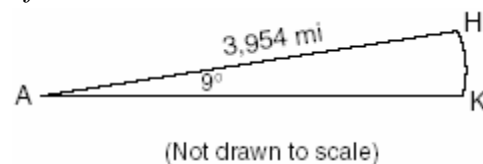

211. Kathy and Tami are at point *A* on a circular track that has a radius of 150 feet, as shown in the accompanying diagram. They run counterclockwise along the track from *A* to *S*, a distance of 247 feet. Find, to the *nearest degree*, the measure of minor arc *AS*.

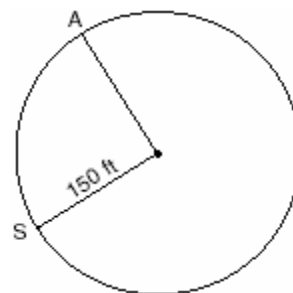

212. The accompanying diagram shows the path of a cart traveling on a circular track of radius 2.40 meters. The cart starts at point  $A$  and stops at point  $B$ , moving in a counterclockwise direction. What is the length of minor arc  $AB$ , over which the cart traveled, to the *nearest tenth of a meter*?

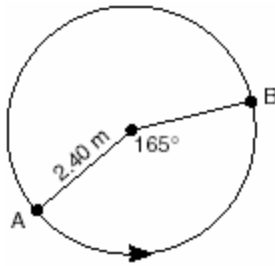

215. As shown in the accompanying diagram, radio station KMA is increasing its radio listening radius from 40 miles to 50 miles. How many additional square miles of listening area, to the *nearest tenth*, will the radio station gain?

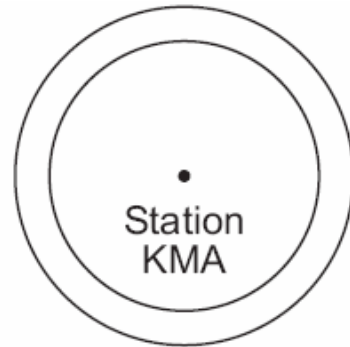

## GEOMETRY CHAPTER 5-8

213. If the circumference of a circle is  $10p$  inches, what is the area, in square inches, of the circle?

[A]  $100p$                       [B]  $25p$   
 [C]  $10p$                         [D]  $50p$

214. In the accompanying diagram, right triangle  $ABC$  is inscribed in circle  $O$ , diameter  $AB = 26$ , and  $CB = 10$ . Find, to the *nearest square unit*, the area of the shaded region.

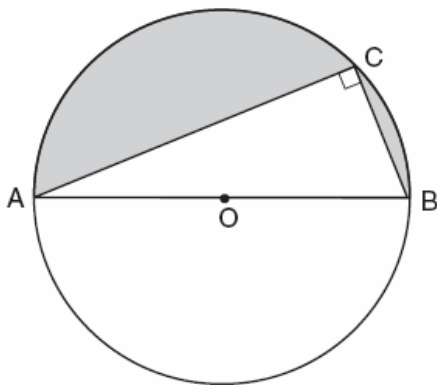

216. Virginia has a circular rug on her square living room floor, as represented in the accompanying diagram. If her entire living room floor measures 100 square feet, what is the area of the part of the floor covered by the rug?

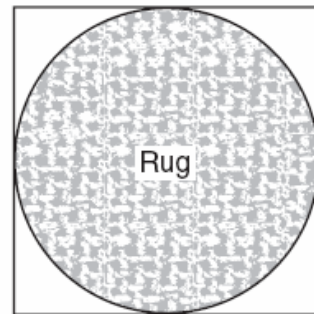

217. In the accompanying diagram, a circle with radius 4 is inscribed in a square.

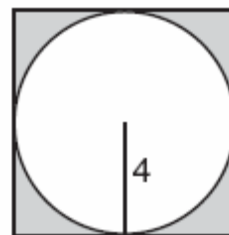

What is the area of the shaded region?

[A]  $16 - 8p$                       [B]  $16 - 16p$   
 [C]  $64 - 16p$                     [D]  $64p - 8p$



218. If asphalt pavement costs \$0.78 per square foot, determine, to the *nearest cent*, the cost of paving the shaded circular road with center O, an outside radius of 50 feet, and an inner radius of 36 feet, as shown in the accompanying diagram.

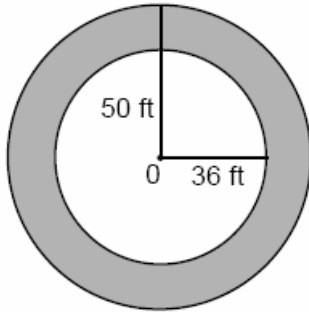

219. A target shown in the accompanying diagram consists of three circles with the same center. The radii of the circles have lengths of 3 inches, 7 inches, and 9 inches.

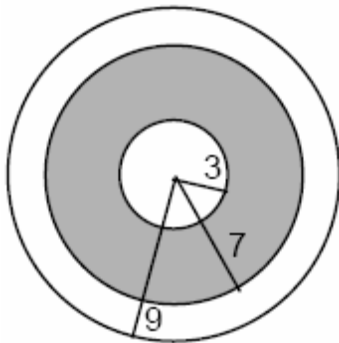

- a What is the area of the shaded region to the *nearest tenth of a square inch*?
- b To the *nearest percent*, what percent of the target is shaded?

220. Mr. Petri has a rectangular plot of land with length = 20 feet and width = 10 feet. He wants to design a flower garden in the shape of a circle with two semicircles at each end of the center circle, as shown in the accompanying diagram. He will fill in the shaded area with wood chips. If one bag of wood chips covers 5 square feet, how many bags must he buy?

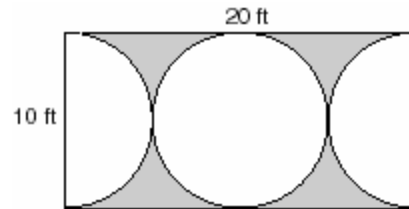

221. The circumference of a circular plot of land is increased by 10%. What is the best estimate of the total percentage that the area of the plot increased?

[A] 21% [B] 10% [C] 31% [D] 25%

## GEOMETRY CHAPTER 6-1

222. Which piece of paper can be folded into a pyramid?

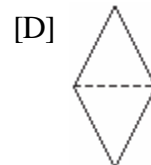
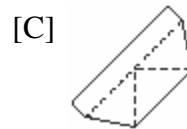
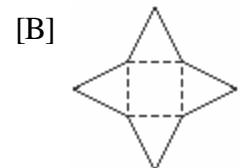

## GEOMETRY CHAPTER 6-2

223. A roll of candy is shown in the accompanying diagram.



The shape of the candy is best described as a

- [A] cone                      [B] rectangular solid  
[C] pyramid                 [D] cylinder

## GEOMETRY CHAPTER 6-3

224. Triangle  $ABC$  represents a metal flag on pole  $AD$ , as shown in the accompanying diagram. On a windy day the triangle spins around the pole so fast that it looks like a three-dimensional shape.

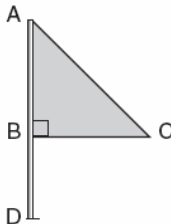

Which shape would the spinning flag create?

- [A] cone            [B] pyramid  
[C] right circular cylinder      [D] sphere

## GEOMETRY CHAPTER 6-4

225. A box in the shape of a cube has a volume of 64 cubic inches. What is the length of a side of the box?

- [A] 4 in                      [B]  $21\bar{3}$  in  
[C] 8 in                      [D] 16 in

226. Which diagram represents the figure with the greatest volume?

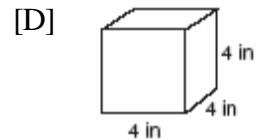
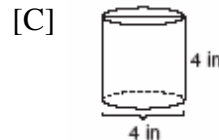
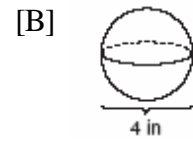
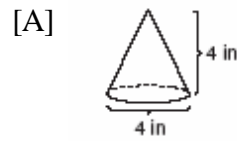

227. The volume of a cube is 64 cubic inches. Its total surface area, in square inches, is

- [A] 16      [B] 48      [C] 96      [D] 576

228. A storage container in the shape of a right circular cylinder is shown in the accompanying diagram.

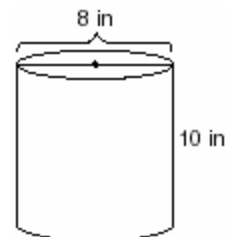

What is the volume of this container, to the nearest hundredth?

- [A] 502.65 in<sup>3</sup>                 [B] 251.33 in<sup>3</sup>  
[C] 56.55 in<sup>3</sup>                 [D] 125.66 in<sup>3</sup>

229. A cardboard box has length  $x - 2$ , width  $x + 1$ , and height  $2x$ .

*a* Write an expression, in terms of  $x$ , to represent the volume of the box.

*b* If  $x = 8$  centimeters, what is the number of cubic centimeters in the volume of the box?

230. Deborah built a box by cutting 3-inch squares from the corners of a rectangular sheet of cardboard, as shown in the accompanying diagram, and then folding the sides up. The volume of the box is 150 cubic inches, and the longer side of the box is 5 inches more than the shorter side. Find the number of inches in the shorter side of the *original* sheet of cardboard.

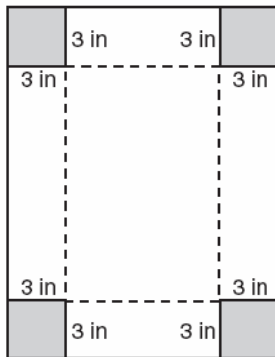

231. The volume of a rectangular pool is 1,080 cubic meters. Its length, width, and depth are in the ratio 10:4:1. Find the number of meters in each of the three dimensions of the pool.
232. A fish tank with a rectangular base has a volume of 3,360 cubic inches. The length and width of the tank are 14 inches and 12 inches, respectively. Find the height, in inches, of the tank.
233. The dimensions of a brick, in inches, are 2 by 4 by 8. How many such bricks are needed to have a total volume of exactly 1 cubic foot?
234. Tina's preschool has a set of cardboard building blocks, each of which measures 9 inches by 9 inches by 4 inches. How many of these blocks will Tina need to build a wall 4 inches thick, 3 feet high, and 12 feet long?

235. Tamika has a hard rubber ball whose circumference measures 13 inches. She wants to box it for a gift but can only find cube-shaped boxes of sides 3 inches, 4 inches, 5 inches, or 6 inches. What is the *smallest* box that the ball will fit into with the top on?

236. In the accompanying diagram, a rectangular container with the dimensions 10 inches by 15 inches by 20 inches is to be filled with water, using a cylindrical cup whose radius is 2 inches and whose height is 5 inches. What is the maximum number of full cups of water that can be placed into the container without the water overflowing the container?

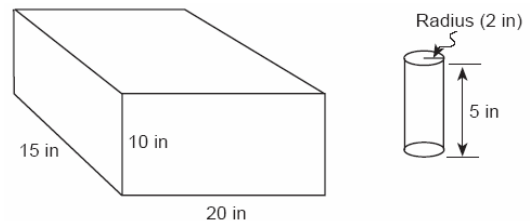

237. As shown in the accompanying diagram, the length, width, and height of Richard's fish tank are 24 inches, 16 inches, and 18 inches, respectively. Richard is filling his fish tank with water from a hose at the rate of 500 cubic inches per minute. How long will it take, to the *nearest minute*, to fill the tank to a depth of 15 inches?

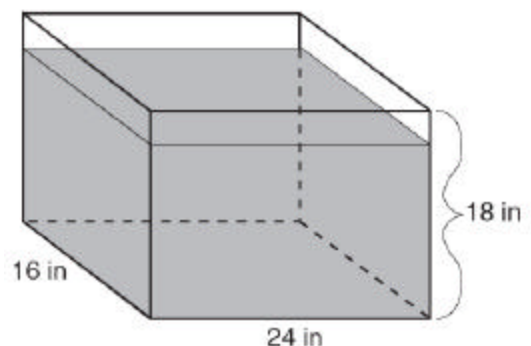

(Not drawn to scale)

238. A rectangular piece of cardboard is to be formed into an uncovered box. The piece of cardboard is 2 centimeters longer than it is wide. A square that measures 3 centimeters on a side is cut from each corner. When the sides are turned up to form the box, its volume is 765 cubic centimeters. Find the dimensions, in centimeters, of the original piece of cardboard.

## GEOMETRY CHAPTER 6-8

239. At a school fair, the spinner represented in the accompanying diagram is spun twice.

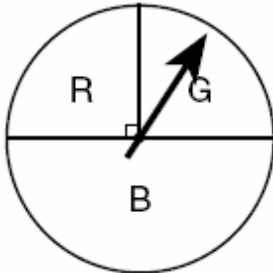

What is the probability that it will land in section *G* the first time and then in section *B* the second time?

- [A]  $\frac{1}{2}$     [B]  $\frac{1}{16}$     [C]  $\frac{1}{8}$     [D]  $\frac{1}{4}$

240. A square dartboard is represented in the accompanying diagram. The entire dartboard is the first quadrant from  $x = 0$  to 6 and from  $y = 0$  to 6. A triangular region on the dartboard is enclosed by the graphs of the equations  $y = 2$ ,  $x = 6$ , and  $y = x$ . Find the probability that a dart that randomly hits the dartboard will land in the triangular region formed by the three lines.

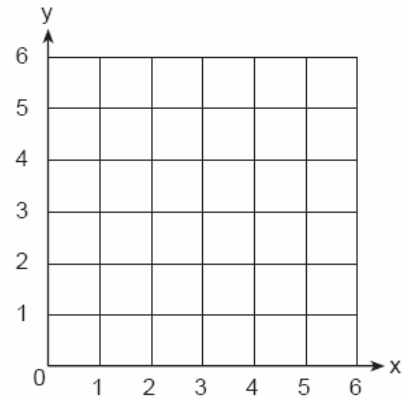

## GEOMETRY CHAPTER 7-1

241. In the accompanying figure, what is one pair of alternate interior angles?

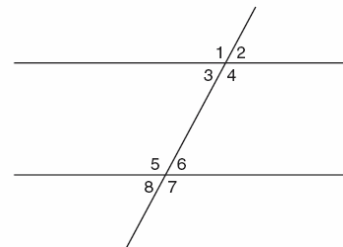

- [A]  $\angle 4$  and  $\angle 6$     [B]  $\angle 6$  and  $\angle 8$   
 [C]  $\angle 1$  and  $\angle 2$     [D]  $\angle 4$  and  $\angle 5$

242. In the accompanying diagram, lines  $a$  and  $b$  are parallel, and lines  $c$  and  $d$  are transversals.

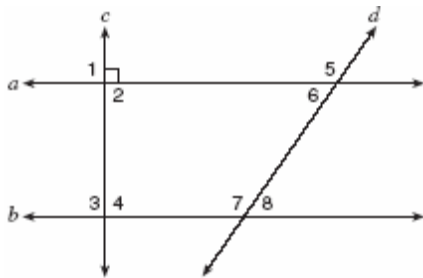

Which angle is congruent to angle 8?

- [A] 5 [B] 6 [C] 4 [D] 3

243. In the accompanying diagram, parallel lines  $\overline{AB}$  and  $\overline{CD}$  are intersected by transversal  $\overline{EF}$  at points  $G$  and  $H$ , respectively,  $m\angle AGH = x + 15$ , and  $m\angle GHD = 2x$ .

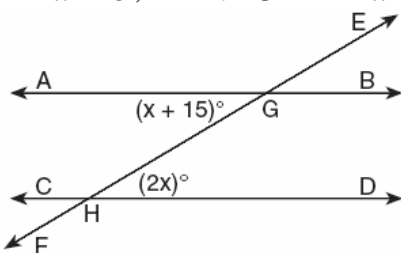

Which equation can be used to find the value of  $x$ ?

- [A]  $2x(x + 15) = 0$  [B]  $2x + x + 15 = 180$   
 [C]  $2x = x + 15$  [D]  $2x + x + 15 = 90$

244. The accompanying diagram shows a football player crossing the 20-yard line at an angle of  $30^\circ$  and continuing along the same path.

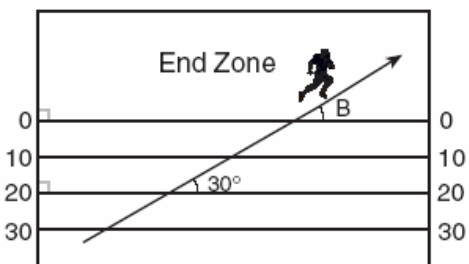

What is the measure of angle  $B$ , where the player crosses into the end zone?

- [A]  $30^\circ$  [B]  $60^\circ$  [C]  $150^\circ$  [D]  $180^\circ$

245. The accompanying diagram shows two parallel streets, Main Street and Brooks Road, intersected by Jay Street. The obtuse angle that Jay Street forms with Brooks Road is three times the measure of the acute angle that Jay Street forms with Main Street.

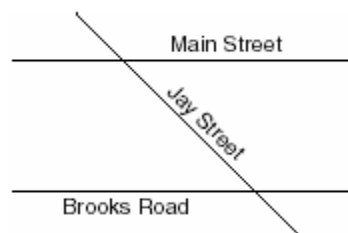

What is the measure of the acute angle formed by Jay Street and Main Street?

- [A]  $90^\circ$  [B]  $135^\circ$  [C]  $45^\circ$  [D]  $60^\circ$

246. In the accompanying diagram, parallel lines  $\overline{AB}$  and  $\overline{CD}$  are intersected by transversal  $\overline{EF}$  at points  $X$  and  $Y$ , and  $m\angle FYD = 123$ . Find  $m\angle AXY$ .

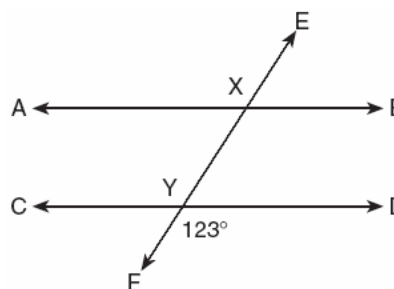

247. In the accompanying diagram, line  $m$  is parallel to line  $p$ , line  $t$  is a transversal,  $m\angle a = 3x + 12$ , and  $m\angle b = 2x + 13$ . Find the value of  $x$ .

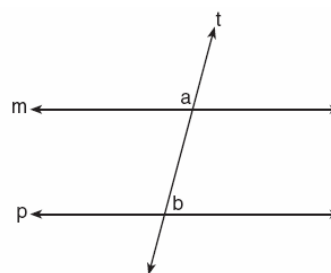

248. Two parallel roads, Elm Street and Oak Street, are crossed by a third, Walnut Street, as shown in the accompanying diagram. Find the number of degrees in the acute angle formed by the intersection of Walnut Street and Elm Street.

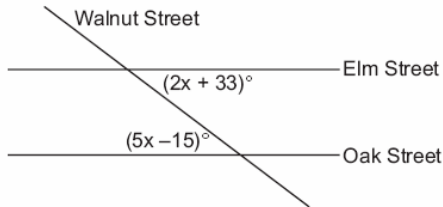

## GEOMETRY CHAPTER 8-4

249. Complete the partial proof below for the accompanying diagram by providing reasons for steps 3, 6, 8, and 9.

Given:  $\overline{AFCD}$   
 $\overline{AB} \perp \overline{BC}$   
 $\overline{DE} \perp \overline{EF}$   
 $\overline{BC} \parallel \overline{FE}$   
 $\overline{AB} \cong \overline{DE}$

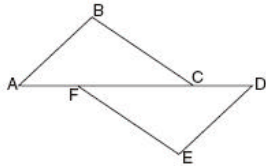

Prove:  $\overline{AC} \cong \overline{FD}$

Statements	Reasons
1 $\overline{AFCD}$	1 Given
2 $\overline{AB} \perp \overline{BC}$ , $\overline{DE} \perp \overline{EF}$	2 Given
3 $\angle B$ and $\angle E$ are right angles.	3 _____
4 $\angle B \cong \angle E$	4 All right angles are congruent.
5 $\overline{BC} \parallel \overline{FE}$	5 Given
6 $\angle BCA \cong \angle EFD$	6 _____
7 $\overline{AB} \cong \overline{DE}$	7 Given
8 $\triangle ABC \cong \triangle DEF$	8 _____
9 $\overline{AC} \cong \overline{FD}$	9 _____

## GEOMETRY CHAPTER 8-6

250. In the accompanying diagram of  $\triangle ABC$ ,  $\overline{AB} \cong \overline{AC}$ ,  $\overline{BD} = \frac{1}{3} \overline{BA}$ , and  $\overline{CE} = \frac{1}{3} \overline{CA}$ .

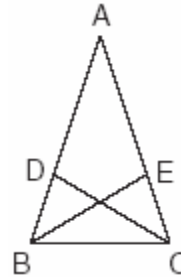

Triangle  $EBC$  can be proved congruent to triangle  $DCB$  by

- [A] HL  $\cong$  HL            [B] SSS  $\cong$  SSS  
 [C] SAS  $\cong$  SAS            [D] ASA  $\cong$  ASA

## GEOMETRY CHAPTER 8-7

251. In the accompanying diagram,  $\overline{CA} \perp \overline{AB}$ ,  $\overline{ED} \perp \overline{DF}$ ,  $\overline{ED} \parallel \overline{AB}$ ,  $\overline{CB} \cong \overline{BF}$ ,  $\overline{AB} \cong \overline{ED}$  and  $m\angle CAB = m\angle FDE = 90$ .

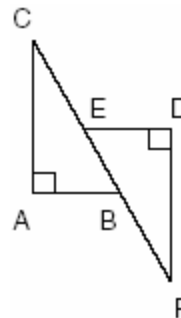

Which statement would *not* be used to prove  $\triangle ABC \cong \triangle DEF$  ?

- [A] SAS  $\cong$  SAS            [B] HL  $\cong$  HL  
 [C] AAS  $\cong$  AAS            [D] SSS  $\cong$  SSS

252. In the accompanying diagram of parallelogram  $ABCD$ ,  $\overline{DE} \cong \overline{BF}$ .

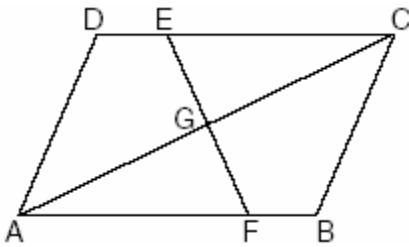

Triangle  $EGC$  can be proved congruent to triangle  $FGA$  by

- [A]  $HL \cong HL$             [B]  $AAA \cong AAA$   
[C]  $AAS \cong AAS$         [D]  $SSA \cong SSA$
253. In the accompanying diagram,  $\overline{HK}$  bisects  $\overline{IL}$  and  $\angle H \cong \angle K$ .

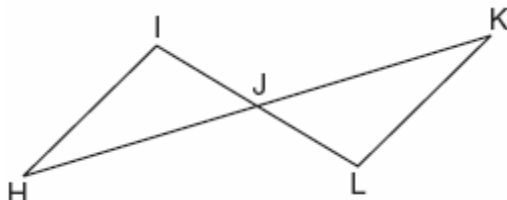

What is the most direct method of proof that could be used to prove  $\triangle HIJ \cong \triangle KLJ$ ?

- [A]  $AAS \cong AAS$             [B]  $ASA \cong ASA$   
[C]  $HL \cong HL$             [D]  $SAS \cong SAS$
254. Which condition does *not* prove that two triangles are congruent?
- [A]  $SSS \cong SSS$             [B]  $SSA \cong SSA$   
[C]  $ASA \cong ASA$             [D]  $SAS \cong SAS$
255. Which statements could be used to prove that  $\triangle ABC$  and  $\triangle A'B'C'$  are congruent?
- [A]  $\angle A \cong \angle A'$ ,  $\angle B \cong \angle B'$ , and  $\angle C \cong \angle C'$   
[B]  $\overline{AB} \cong \overline{A'B'}$ ,  $\angle A \cong \angle A'$ , and  $\angle C \cong \angle C'$   
[C]  $\overline{AB} \cong \overline{A'B'}$ ,  $\overline{BC} \cong \overline{B'C'}$ , and  $\angle A \cong \angle A'$   
[D]  $\angle A \cong \angle A'$ ,  $\overline{AC} \cong \overline{A'C'}$ , and  $\overline{BC} \cong \overline{B'C'}$

## GEOMETRY CHAPTER 9-1

256. In the accompanying diagram of parallelogram  $ABCD$ , diagonals  $\overline{AC}$  and  $\overline{DB}$  intersect at  $E$ ,  $AE = 3x - 4$ , and  $EC = x + 12$ .

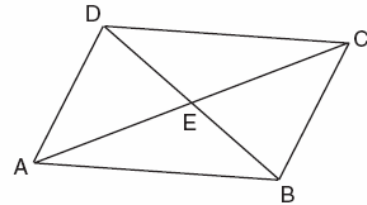

What is the value of  $x$ ?

- [A] 40    [B] 8    [C] 20    [D] 16
257. In the accompanying diagram of parallelogram  $ABCD$ ,  $m\angle A = (2x + 10)$  and  $m\angle B = 3x$ . Find the number of degrees in  $m\angle B$ .

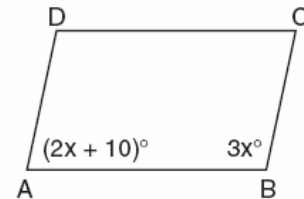

## GEOMETRY CHAPTER 9-2

258. Prove that the diagonals of a parallelogram bisect each other.
259. Given: parallelogram  $ABCD$ , diagonal  $\overline{AC}$ , and  $\overline{ABE}$

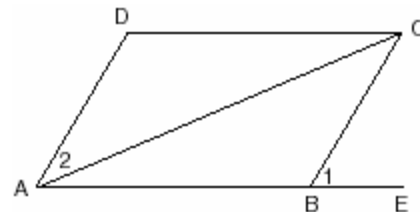

Prove:  $m\angle 1 > m\angle 2$

260. In the accompanying diagram of  $ABCD$ , where  $a \neq b$ , prove  $ABCD$  is an isosceles trapezoid.

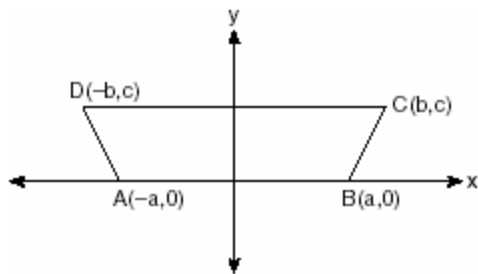

### GEOMETRY CHAPTER 9-3

261. Which quadrilateral must have diagonals that are congruent and perpendicular?

- [A] parallelogram      [B] rhombus  
[C] trapezoid          [D] square

262. In the accompanying diagram of rectangle  $ABCD$ ,  $m\angle BAC = 3x + 4$  and  $m\angle ACD = x + 28$ .

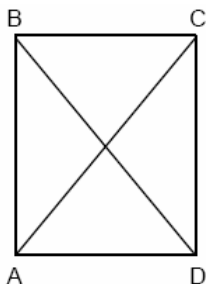

What is  $m\angle CAD$ ?

- [A] 12      [B] 37      [C] 50      [D] 40

263. In rectangle  $ABCD$ ,  $AC = 3x + 15$  and  $BD = 4x - 5$ . Find the length of  $\overline{AC}$ .

### GEOMETRY CHAPTER 9-6

264. Ashanti is surveying for a new parking lot shaped like a parallelogram. She knows that three of the vertices of parallelogram  $ABCD$  are  $A(0,0)$ ,  $B(5,2)$ , and  $C(6,5)$ . Find the coordinates of point  $D$  and sketch parallelogram  $ABCD$  on the accompanying set of axes. Justify mathematically that the figure you have drawn is a parallelogram.

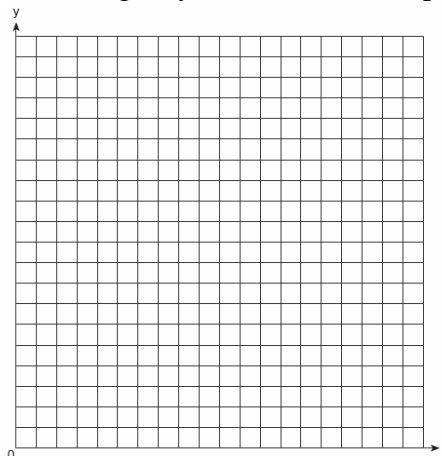

265. Given:  $A(1,6)$ ,  $B(7,9)$ ,  $C(13,6)$ , and  $D(3,1)$   
Prove:  $ABCD$  is a trapezoid. [The use of the accompanying grid is optional.]

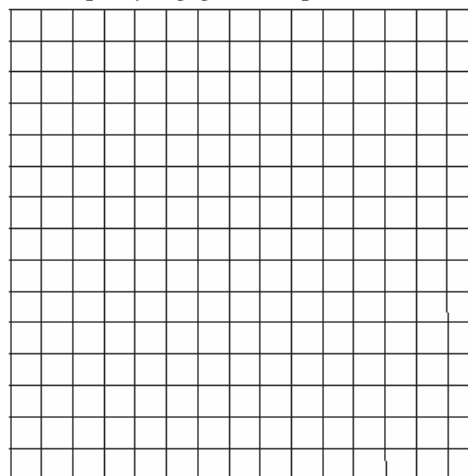



266. Quadrilateral  $KATE$  has vertices  $K(1,5)$ ,  $A(4,7)$ ,  $T(7,3)$ , and  $E(1,-1)$ .

a Prove that  $KATE$  is a trapezoid. [The use of the grid is optional.]

b Prove that  $KATE$  is *not* an isosceles trapezoid.

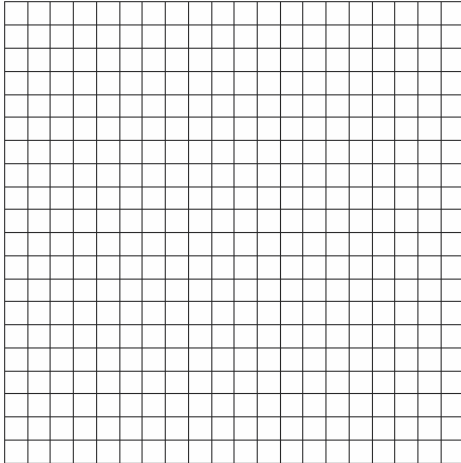

268. The coordinates of quadrilateral  $JKLM$  are  $J(1,-2)$ ,  $K(13,4)$ ,  $L(6,8)$ , and  $M(-2,4)$ . Prove that quadrilateral  $JKLM$  is a trapezoid but not an isosceles trapezoid. [The use of the grid is optional.]

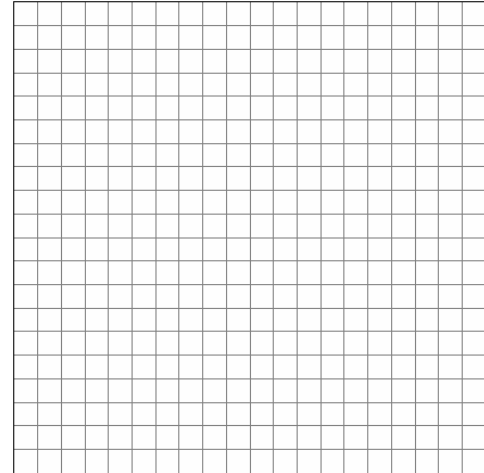

267. The coordinates of quadrilateral  $ABCD$  are  $A(-1,-5)$ ,  $B(8,2)$ ,  $C(11,13)$ , and  $D(2,6)$ . Using coordinate geometry, prove that quadrilateral  $ABCD$  is a rhombus. [The use of the grid is optional.]

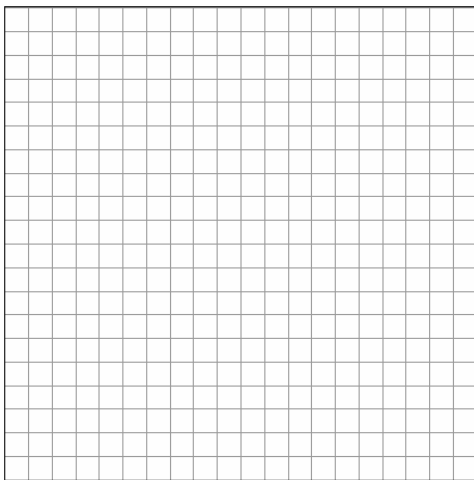

269. Jim is experimenting with a new drawing program on his computer. He created quadrilateral  $TEAM$  with coordinates  $T(-2,3)$ ,  $E(-5,-4)$ ,  $A(2,-1)$ , and  $M(5,6)$ . Jim believes that he has created a rhombus but not a square. Prove that Jim is correct. [The use of the grid is optional.]

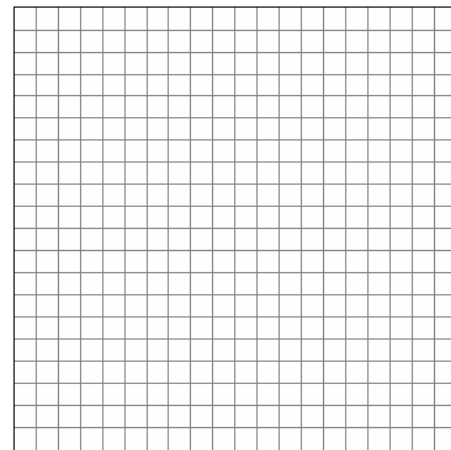

## GEOMETRY CHAPTER 10-1

270. A triangle has sides whose lengths are 5, 12, and 13. A similar triangle could have sides with lengths of

[A] 3, 4, and 15      [B] 6, 8, and 10  
[C] 10, 24, and 26      [D] 7, 24, and 25

271. The accompanying diagram shows two similar triangles.

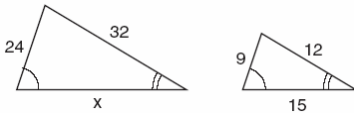

Which proportion could be used to solve for  $x$ ?

[A]  $\frac{32}{x} = \frac{12}{15}$       [B]  $\frac{32}{12} = \frac{15}{x}$   
[C]  $\frac{24}{9} = \frac{15}{x}$       [D]  $\frac{x}{24} = \frac{9}{15}$

272. The Rivera family bought a new tent for camping. Their old tent had equal sides of 10 feet and a floor width of 15 feet, as shown in the accompanying diagram.

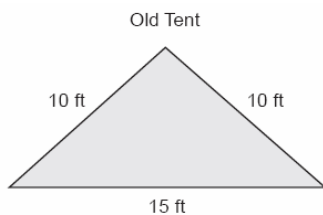

If the new tent is similar in shape to the old tent and has equal sides of 16 feet, how wide is the floor of the new tent?

273. The accompanying diagram shows a section of the city of Tacoma. High Road, State Street, and Main Street are parallel and 5 miles apart. Ridge Road is perpendicular to the three parallel streets. The distance between the intersection of Ridge Road and State Street and where the railroad tracks cross State Street is 12 miles. What is the distance between the intersection of Ridge Road and Main Street and where the railroad tracks cross Main Street?

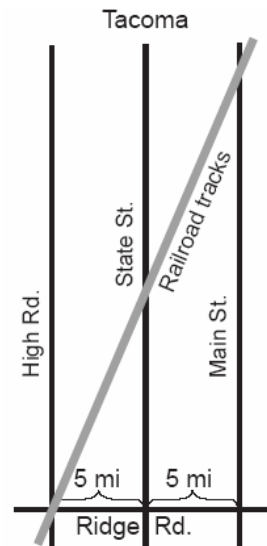

274. Fran's favorite photograph has a length of 6 inches and a width of 4 inches. She wants to have it made into a poster with dimensions that are similar to those of the photograph. She determined that the poster should have a length of 24 inches. How many inches wide will the poster be?

## GEOMETRY CHAPTER 10-5

275. The perimeter of  $\triangle A'B'C'$ , the image of  $\triangle ABC$ , is twice as large as the perimeter of  $\triangle ABC$ . What type of transformation has taken place?

[A] reflection      [B] rotation  
[C] dilation      [D] translation

276. Delroy's sailboat has two sails that are similar triangles. The larger sail has sides of 10 feet, 24 feet, and 26 feet. If the shortest side of the smaller sail measures 6 feet, what is the perimeter of the *smaller* sail?

[A] 15 ft [B] 100 ft [C] 60 ft [D] 36 ft

277. Two triangles are similar. The lengths of the sides of the smaller triangle are 3, 5, and 6, and the length of the longest side of the larger triangle is 18. What is the perimeter of the larger triangle?

[A] 18 [B] 14 [C] 42 [D] 24

278. The perimeter of an equilateral triangle varies directly as the length of a side. When the length of a side is doubled, the perimeter of the triangle is

[A] doubled [B] divided by 3  
[C] multiplied by 3 [D] halved

279. In the accompanying diagram of equilateral triangle  $ABC$ ,  $DE = 5$  and  $\overline{DE} \parallel \overline{AB}$ .

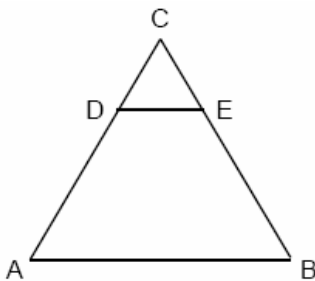

If  $AB$  is three times as long as  $DE$ , what is the perimeter of quadrilateral  $ABED$ ?

[A] 20 [B] 30 [C] 35 [D] 40

280. On a scale drawing of a new school playground, a triangular area has sides with lengths of 8 centimeters, 15 centimeters, and 17 centimeters. If the triangular area located on the playground has a perimeter of 120 meters, what is the length of its longest side?

[A] 24 m [B] 51 m  
[C] 40 m [D] 45 m

281. The ratio of the corresponding sides of two similar squares is 1 to 3. What is the ratio of the area of the smaller square to the area of the larger square ?

[A] 1:6 [B] 1:9 [C] 1:3 [D]  $1:\sqrt{3}$

282. The lengths of the sides of two similar rectangular billboards are in the ratio 5:4. If 250 square feet of material is needed to cover the larger billboard, how much material, in square feet, is needed to cover the smaller billboard?

283. If the circumference of a circle is doubled, the diameter of the circle
- [A] is doubled [B] is multiplied by 4  
[C] increases by 2 [D] remains the same

## GEOMETRY CHAPTER 10-6

284. If the length of a rectangular prism is doubled, its width is tripled, and its height remains the same, what is the volume of the new rectangular prism?

[A] double the original volume  
[B] six times the original volume  
[C] triple the original volume  
[D] nine times the original volume

## GEOMETRY CHAPTER 11-3

285. At Mogul's Ski Resort, the beginner's slope is inclined at an angle of  $12.3^\circ$ , while the advanced slope is inclined at an angle of  $26.4^\circ$ . If Rudy skis 1,000 meters down the advanced slope while Valerie skis the same distance on the beginner's slope, how much longer was the horizontal distance that Valerie covered?

- [A] 977.0 m                      [B] 895.7 m  
[C] 231.6 m                      [D] 81.3 m

## GEOMETRY CHAPTER 11-5

286. Two tow trucks try to pull a car out of a ditch. One tow truck applies a force of 1,500 pounds while the other truck applies a force of 2,000 pounds. The resultant force is 3,000 pounds. Find the angle between the two applied forces, rounded to the *nearest degree*.

287. One force of 20 pounds and one force of 15 pounds act on a body at the same point so that the resultant force is 19 pounds. Find, to the *nearest degree*, the angle between the two original forces.

288. Two equal forces act on a body at an angle of  $80^\circ$ . If the resultant force is 100 newtons, find the value of one of the two equal forces, to the *nearest hundredth of a newton*.

## GEOMETRY CHAPTER 11-6

289. Gregory wants to build a garden in the shape of an isosceles triangle with one of the congruent sides equal to 12 yards. If the area of his garden will be 55 square yards, find, to the *nearest tenth of a degree*, the *three* angles of the triangle.

290. The accompanying diagram shows the floor plan for a kitchen. The owners plan to carpet all of the kitchen except the "work space," which is represented by scalene triangle  $ABC$ . Find the area of this work space to the *nearest tenth of a square foot*.

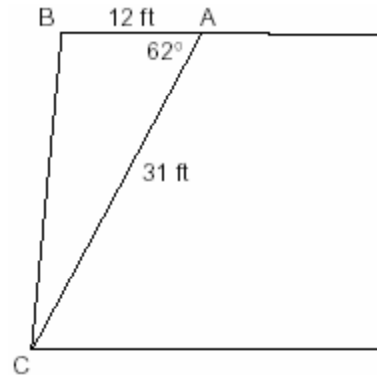

291. Two sides of a triangular-shaped pool measure 16 feet and 21 feet, and the included angle measures  $58^\circ$ . What is the area, to the *nearest tenth of a square foot*, of a nylon cover that would exactly cover the surface of the pool?

292. The triangular top of a table has two sides of 14 inches and 16 inches, and the angle between the sides is  $30^\circ$ . Find the area of the tabletop, in square inches.

293. A landscape architect is designing a triangular garden to fit in the corner of a lot. The corner of the lot forms an angle of  $70^\circ$ , and the sides of the garden including this angle are to be 11 feet and 13 feet, respectively. Find, to the *nearest integer*, the number of square feet in the area of the garden.

## GEOMETRY CHAPTER 12-1

294. What is the greatest possible number of points of intersection of a triangle and a circle?

- [A] 3                      [B] 6                      [C] 2                      [D] 4

295. In the coordinate plane, the points (2,2) and (2,12) are the endpoints of a diameter of a circle. What is the length of the radius of the circle?

- [A] 7      [B] 10      [C] 5      [D] 6

296. *a* On the set of axes provided below, sketch a circle with a radius of 3 and center at (2,1) and also sketch the graph of the line  $2x + y = 8$ .

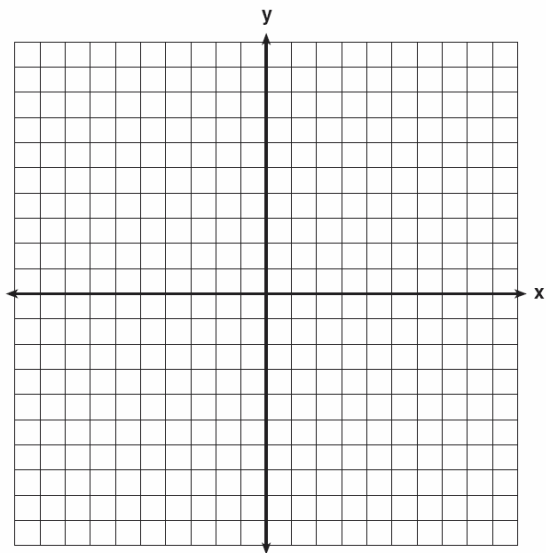

*b* What is the total number of points of intersection of the two graphs?

297. On the accompanying grid, graph a circle whose center is at (0,0) and whose radius is 5. Determine if the point (5,-2) lies on the circle.

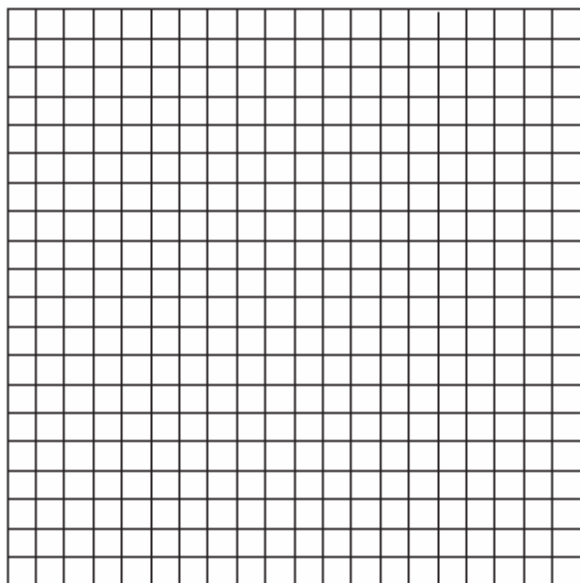

298. Which equation represents a circle whose center is (3,-2)?

- [A]  $(x - 2)^2 + (y + 3)^2 = 4$   
 [B]  $(x - 3)^2 + (y + 2)^2 = 4$   
 [C]  $(x + 2)^2 + (y - 3)^2 = 4$   
 [D]  $(x + 3)^2 + (y - 2)^2 = 4$

299. Which equation represents the locus of points 4 units from the origin?

- [A]  $x + y = 16$       [B]  $x^2 + y^2 = 16$   
 [C]  $x^2 + y^2 = 4$       [D]  $x = 4$

300. What is the total number of points of intersection in the graphs of the equations  $x^2 + y^2 = 16$  and  $y = 4$ ?

- [A] 0      [B] 2      [C] 1      [D] 3

301. The graph of the equation  $x^2 + y^2 = 4$  can be described as a

- [A] circle with its center at the origin and a radius of 2  
 [B] circle with its center at the origin and a radius of 4  
 [C] line passing through points (0,2) and (2,0)  
 [D] parabola with its vertex at (0,2)

302. John uses the equation  $x^2 + y^2 = 9$  to represent the shape of a garden on graph paper.

a Graph  $x^2 + y^2 = 9$  on the accompanying grid.

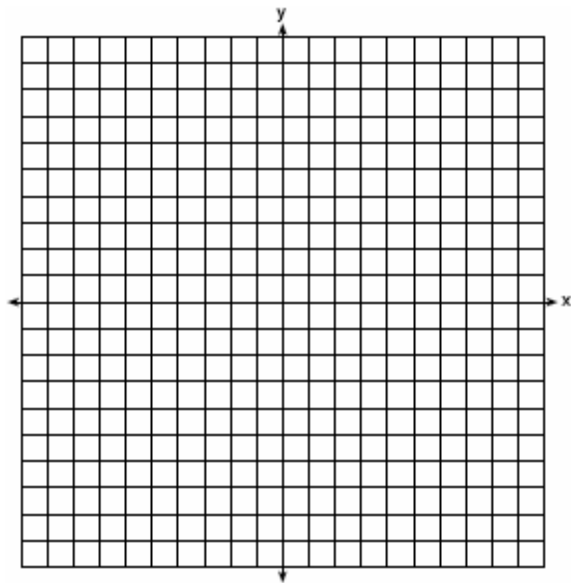

b What is the area of the garden to the nearest square unit?

303. Solve the following system of equations algebraically or graphically:

$$x^2 + y^2 = 25$$

$$3y - 4x = 0$$

[The use of the accompanying grid is optional.]

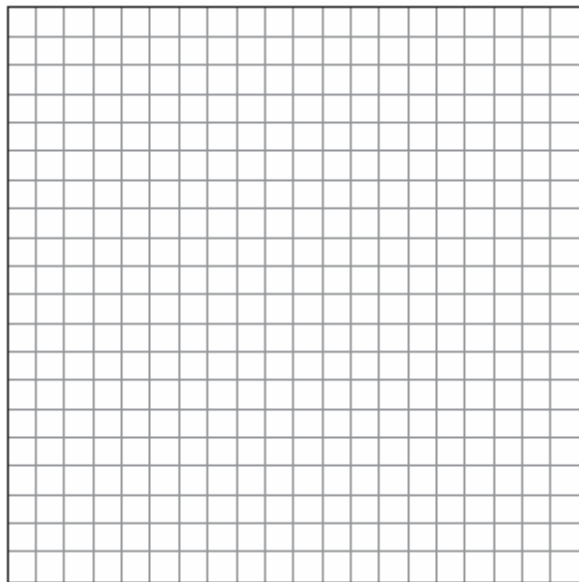

## GEOMETRY CHAPTER 12-2

304. Kimi wants to determine the radius of a circular pool without getting wet. She is located at point  $K$ , which is 4 feet from the pool and 12 feet from the point of tangency, as shown in the accompanying diagram.

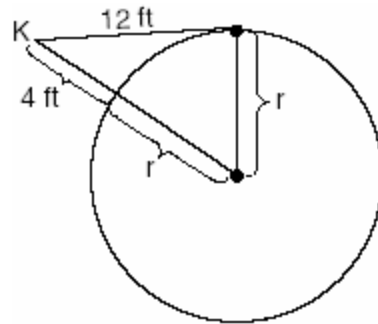

What is the radius of the pool?

[A] 20 ft

[B] 32 ft

[C] 16 ft

[D]  $4\sqrt{10}$  ft

305. In the accompanying diagram of circle  $O$ ,  $\overline{PA}$  is drawn tangent to the circle at  $A$ . Place  $B$  on  $\overline{PA}$  anywhere between  $P$  and  $A$  and draw  $\overline{OA}$ ,  $\overline{OP}$ , and  $\overline{OB}$ . Prove that  $\overline{OB}$  is not perpendicular to  $\overline{PA}$ .

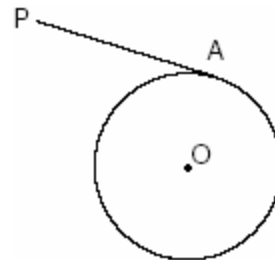

## GEOMETRY CHAPTER 12-3

306. An overhead view of a revolving door is shown in the accompanying diagram. Each panel is 1.5 meters wide.

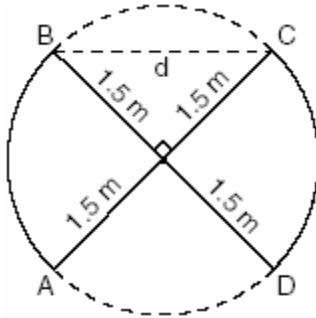

What is the approximate width of  $d$ , the opening from  $B$  to  $C$ ?

- [A] 1.50 m                      [B] 3.00 m  
[C] 1.73 m                      [D] 2.12 m
307. A toy truck is located within a circular play area. Alex and Dominic are sitting on opposite endpoints of a chord that contains the truck. Alex is 4 feet from the truck, and Dominic is 3 feet from the truck. Meira and Tamara are sitting on opposite endpoints of another chord containing the truck. Meira is 8 feet from the truck. How many feet, to the *nearest tenth of a foot*, is Tamara from the truck? Draw a diagram to support your answer.

## GEOMETRY CHAPTER 12-4

308. A regular hexagon is inscribed in a circle. What is the ratio of the length of a side of the hexagon to the minor arc that it intercepts?

- [A]  $\frac{3}{p}$     [B]  $\frac{p}{6}$     [C]  $\frac{6}{p}$     [D]  $\frac{3}{6}$

309. Given: chords  $\overline{AB}$  and  $\overline{CD}$  of circle  $O$  intersect at  $E$ , an interior point of circle  $O$ ; chords  $\overline{AD}$  and  $\overline{CB}$  are drawn.

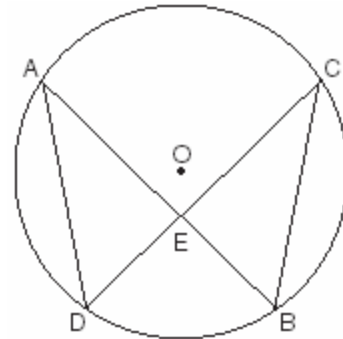

Prove:  $(AE)(EB) = (CE)(ED)$

310. The new corporate logo created by the design engineers at Magic Motors is shown in the accompanying diagram.

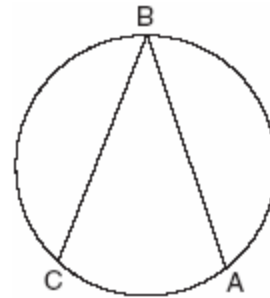

If chords  $\overline{BA}$  and  $\overline{BC}$  are congruent and  $m\widehat{BC} = 140$ , what is  $m\angle B$ ?

- [A] 280    [B] 80    [C] 40    [D] 140
311. In the accompanying diagram, the length of  $\widehat{ABC}$  is  $\frac{3p}{2}$  radians.

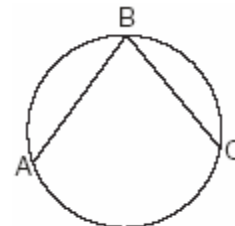

(Not drawn to scale)

What is  $m\angle ABC$ ?

- [A] 45    [B] 36    [C] 53    [D] 72

312. The accompanying diagram shows a child's spin toy that is constructed from two chords intersecting in a circle. The curved edge of the larger shaded section is one-quarter of the circumference of the circle, and the curved edge of the smaller shaded section is one-fifth of the circumference of the circle.

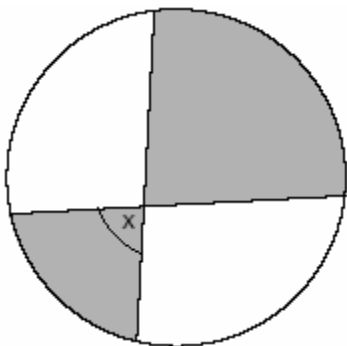

What is the measure of angle  $x$ ?

- [A]  $72^\circ$  [B]  $108^\circ$  [C]  $40^\circ$  [D]  $81^\circ$
313. The accompanying diagram represents circular pond  $O$  with docks located at points  $A$  and  $B$ . From a cabin located at  $C$ , two sightings are taken that determine an angle of  $30^\circ$  for tangents  $\overline{CA}$  and  $\overline{CB}$ .

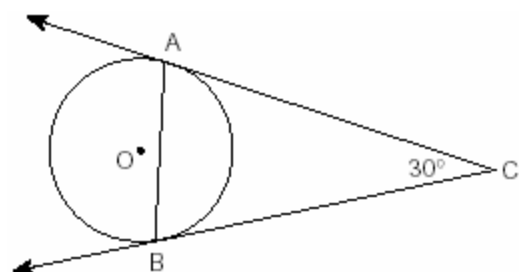

What is  $m\angle CAB$ ?

- [A] 60 [B] 30 [C] 75 [D] 150

314. An architect is designing a park with an entrance represented by point  $C$  and a circular garden with center  $O$ , as shown in the accompanying diagram. The architect plans to connect three points on the circumference of the garden,  $A$ ,  $B$ , and  $D$ , to the park entrance,  $C$ , with walkways so that walkways  $\overline{CA}$  and  $\overline{CB}$  are tangent to the garden, walkway  $\overline{DOEC}$  is a path through the center of the garden,  $m\widehat{ADB} : m\widehat{AEB} = 3 : 2$ ,  $BC = 60$  meters, and  $EC = 43.6$  meters. Find the measure of the angle between walkways  $\overline{CA}$  and  $\overline{CB}$ . Find the diameter of the circular garden, to the nearest meter.

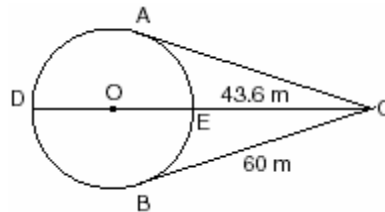

315. A small fragment of something brittle, such as pottery, is called a shard. The accompanying diagram represents the outline of a shard from a small round plate that was found at an archaeological dig.

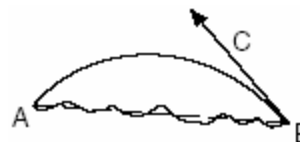

If  $\overline{BC}$  is a tangent to  $\widehat{AC}$  at  $B$  and  $m\angle ABC = 45$ , what is the measure of  $\widehat{AC}$ , the outside edge of the shard?

- [A]  $45^\circ$  [B]  $90^\circ$  [C]  $135^\circ$  [D]  $225^\circ$

316. Point  $P$  lies outside circle  $O$ , which has a diameter of  $\overline{AOC}$ . The angle formed by tangent  $\overline{PA}$  and secant  $\overline{PBC}$  measures  $30^\circ$ . Sketch the conditions given above and find the number of degrees in the measure of minor arc  $CB$ .



317. In the accompanying diagram, cabins  $B$  and  $G$  are located on the shore of a circular lake, and cabin  $L$  is located near the lake. Point  $D$  is a dock on the lake shore and is collinear with cabins  $B$  and  $L$ . The road between cabins  $G$  and  $L$  is 8 miles long and is tangent to the lake. The path between cabin  $L$  and dock  $D$  is 4 miles long.

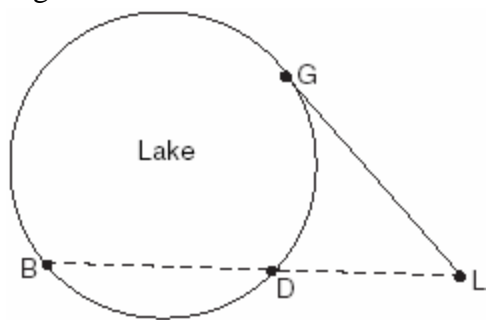

(Not drawn to scale)

What is the length, in miles, of  $\overline{BD}$ ?

- [A] 8      [B] 4      [C] 24      [D] 12

318. The accompanying diagram shows a circular machine part that has rods  $\overline{PT}$  and  $\overline{PAR}$  attached at points  $T$ ,  $A$ , and  $R$ , which are located on the circle;  $m\widehat{TA} : m\widehat{AR} : m\widehat{RT} = 1 : 3 : 5$ ;  $RA = 12$  centimeters; and  $PA = 5$  centimeters.

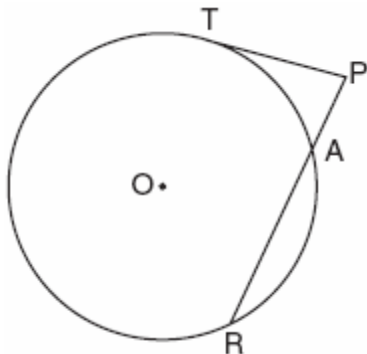

Find the measure of  $\angle P$ , in degrees, and find the length of rod  $\overline{PT}$ , to the nearest tenth of a centimeter.

319. Given circle  $O$  with diameter  $\overline{GOAL}$ ; secants  $\overline{HUG}$  and  $\overline{HTAM}$  intersect at point  $H$ ;  $m\widehat{GM} : m\widehat{ML} : m\widehat{LT} = 7 : 3 : 2$ ; and chord  $\overline{GU} \cong$  chord  $\overline{UT}$ . Find the ratio of  $m\angle UGL$  to  $m\angle H$ .

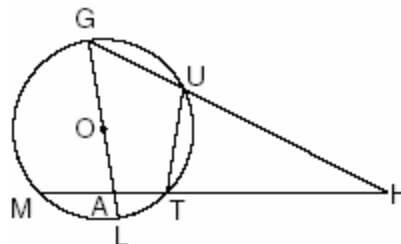

## GEOMETRY CHAPTER 12-6

320. The accompanying diagram shows a semicircular arch over a street that has a radius of 14 feet. A banner is attached to the arch at points  $A$  and  $B$ , such that  $AE = EB = 5$  feet. How many feet above the ground are these points of attachment for the banner?

