

# JEFFERSON MATH PROJECT REGENTS AT RANDOM

All 962 NY Math A Regents Exam Questions  
from June 1999 to January 2008 at Random

[www.jmap.org](http://www.jmap.org)



Dear Sir

I have to acknowledge the receipt of your favor of May 14. in which you mention that you have finished the 6. first books of Euclid, plane trigonometry, surveying & algebra and ask whether I think a further pursuit of that branch of science would be useful to you. there are some propositions in the latter books of Euclid, & some of Archimedes, which are useful, & I have no doubt you have been made acquainted with them. trigonometry, so far as this, is most valuable to every man, there is scarcely a day in which he will not resort to it for some of the purposes of common life. the science of calculation also is indispensable as far as the extraction of the square & cube roots; Algebra as far as the quadratic equation & the use of logarithms are often of value in ordinary cases: but all beyond these is but a luxury; a delicious luxury indeed; but not to be indulged in by one who is to have a profession to follow for his subsistence. in this light I view the conic sections, curves of the higher orders, perhaps even spherical trigonometry, Algebraical operations beyond the 2d dimension, and fluxions.

Letter from Thomas Jefferson to William G. Munford, Monticello, June 18, 1799.

1. 080112a, P.I. A.N.1

The operation element @ is determined by the following table:

@	$a$	$b$	$c$
$a$	$a$	$b$	$c$
$b$	$b$	$c$	$a$
$c$	$c$	$a$	$b$

What is the identity element of this operation?

- [A]  $a$ , only                      [B]  $b$ , only  
[C]  $a$  and  $b$                       [D]  $c$

2. 060629a, P.I. G.G.34

On the banks of a river, surveyors marked locations  $A$ ,  $B$ , and  $C$ . The measure of  $\angle ACB = 70^\circ$  and the measure of  $\angle ABC = 65^\circ$ .

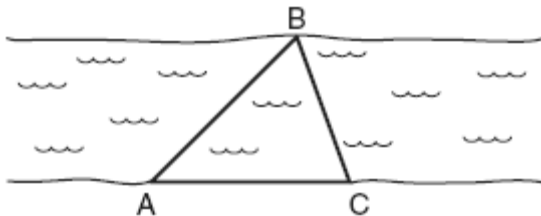

Which expression shows the relationship between the lengths of the sides of this triangle?

- [A]  $BC < AC < AB$       [B]  $AC < AB < BC$   
[C]  $AB < BC < AC$       [D]  $BC < AB < AC$

3. 010419a, P.I. A2.A.7

What is the solution set of the equation  $3x^2 - 34x - 24 = 0$ ?

- [A]  $\{-6, 2\}$                       [B]  $\{-\frac{2}{3}, 12\}$   
[C]  $\{-12, \frac{2}{3}\}$                       [D]  $\{-2, 6\}$

4. 060433a, P.I. 7.N.3

Kyoko's mathematics teacher gave her the accompanying cards and asked her to arrange the cards in order from least to greatest. In what order should Kyoko arrange the cards?

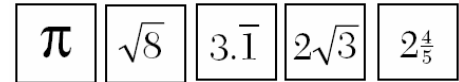

5. 080003a, P.I. G.G.22

In the coordinate plane, what is the total number of points 5 units from the origin and equidistant from both the  $x$ - and  $y$ -axes?

- [A] 2                      [B] 4                      [C] 0                      [D] 1

6. 010636a, P.I. A.A.22

Solve for  $x$ :  $\frac{1}{16}x + \frac{1}{4} = \frac{1}{2}$

7. 060630a, P.I. A.S.20

Which inequality represents the probability,  $x$ , of any event happening?

- [A]  $x < 1$                       [B]  $0 \leq x \leq 1$   
[C]  $0 < x < 1$                       [D]  $x \geq 0$

8. 080030a

Katrina hikes 5 miles north, 7 miles east, and then 3 miles north again. To the *nearest tenth of a mile*, how far, in a straight line, is Katrina from her starting point?

9. 010422a, P.I. A2.A.13

If  $a > 0$ , then  $\sqrt{9a^2 + 16a^2}$  equals

- [A]  $7a$       [B]  $5a$       [C]  $5\sqrt{a}$       [D]  $\sqrt{7a}$

10. 080727a, P.I. A2.S.10

Which expression represents the number of different 8-letter arrangements that can be made from the letters of the word "SAVANNAH" if each letter is used only once?

- [A]  $\frac{8!}{3!2!}$       [B]  $8!$       [C]  ${}_8P_5$       [D]  $\frac{8!}{5!}$

11. 010736a, P.I. G.G.48  
The perimeter of a square is 56. Express the length of a diagonal of the square in simplest radical form.

12. 060008a  
Which equation represents a circle whose center is (3, -2)?

[A]  $(x+3)^2 + (y-2)^2 = 4$

[B]  $(x+2)^2 + (y-3)^2 = 4$

[C]  $(x-2)^2 + (y+3)^2 = 4$

[D]  $(x-3)^2 + (y+2)^2 = 4$

13. 080633a, P.I. A.A.45  
In the accompanying diagram of right triangles  $ABD$  and  $DBC$ ,  $AB = 5$ ,  $AD = 4$ , and  $CD = 1$ . Find the length of  $\overline{BC}$ , to the nearest tenth.

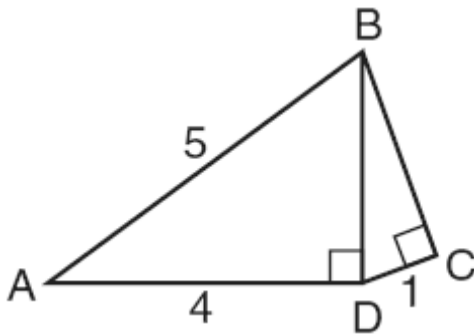

14. 010014a, P.I. A.A.26  
Sterling silver is made of an alloy of silver and copper in the ratio of 37:3. If the mass of a sterling silver ingot is 600 grams, how much silver does it contain?

[A] 450 g                      [B] 555 g

[C] 48.65 g                    [D] 200 g

15. 060229a, P.I. A.A.27  
Solve for  $x$ :  $x^2 + 3x - 28 = 0$

16. 060711a, P.I. G.G.60  
The accompanying diagram shows the transformation of  $\triangle XYZ$  to  $\triangle X'Y'Z'$ .

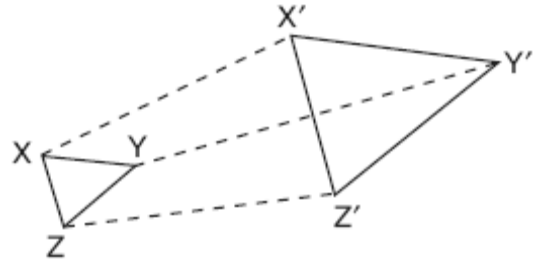

- This transformation is an example of a  
[A] rotation                      [B] line reflection

- [C] translation                    [D] dilation

17. 010420a, P.I. G.G.19  
In the accompanying diagram of a construction, what does  $\overline{PC}$  represent?

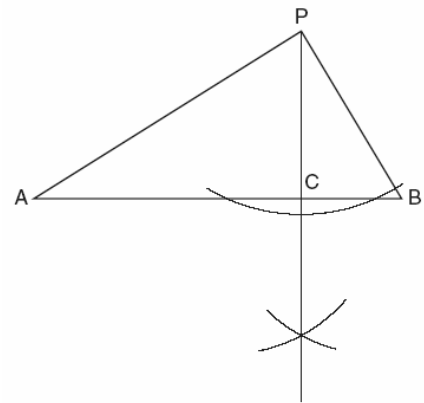

- [A] an altitude drawn to  $\overline{AB}$   
[B] the bisector of  $\angle APB$   
[C] the perpendicular bisector of  $\overline{AB}$   
[D] a median drawn to  $\overline{AB}$

18. 060635a  
On the accompanying square, draw all the lines of symmetry.

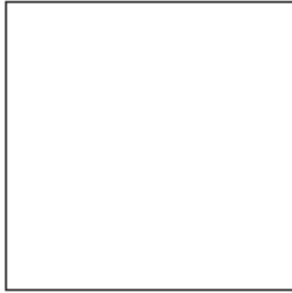

19. 060312a, P.I. A.A.12  
The expression  $3^2 \cdot 3^3 \cdot 3^4$  is equivalent to  
[A]  $3^{24}$  [B]  $3^9$  [C]  $27^{24}$  [D]  $27^9$

20. 060204a, P.I. A.A.6  
During each marking period, there are five tests. If Vanita needs a 65 average to pass this marking period and her first four grades are 60, 72, 55, and 80, what is the *lowest* score she can earn on the last test to have a passing average?  
[A] 100 [B] 65 [C] 80 [D] 58

21. 089906a, P.I. A.A.12  
The product of  $4x^2y$  and  $2xy^3$  is  
[A]  $8x^3y^4$  [B]  $8x^3y^3$   
[C]  $8x^2y^3$  [D]  $8x^2y^4$

22. 010203a, P.I. A.A.37  
What is the slope of the line whose equation is  $2y = 5x + 4$ ?  
[A]  $\frac{5}{2}$  [B] 2 [C] 5 [D]  $\frac{2}{5}$

23. 010222a, P.I. A.A.26  
A 12-foot tree casts a 16-foot shadow. How many feet tall is a nearby tree that casts a 20-foot shadow at the same time?

24. 010015a, P.I. 8.N.2  
If  $t = -3$ , then  $3t^2 + 5t + 6$  equals  
[A] -6 [B] 18 [C] -36 [D] 6

25. 080702a, P.I. 7.S.6  
The accompanying circle graph shows how Joan invested her money.

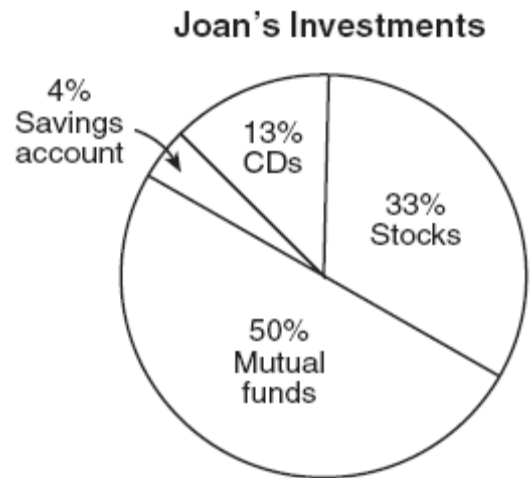

If she invested a total of \$12,000, how much money did she invest in CDs?

- [A] \$15,600 [B] \$92,308  
[C] \$9,230 [D] \$1,560

26. 010413a, P.I. A.A.12  
The expression  $8^{-4} \cdot 8^6$  is equivalent to  
[A]  $8^{-2}$  [B]  $8^{-24}$  [C]  $8^{10}$  [D]  $8^2$

27. 010710a, P.I. A.A.23  
The formula for potential energy is  $P = mgh$ , where  $P$  is potential energy,  $m$  is mass,  $g$  is gravity, and  $h$  is height. Which expression can be used to represent  $g$ ?

- [A]  $\frac{P}{mh}$  [B]  $P - mh$   
[C]  $\frac{P}{m} - h$  [D]  $P - m - h$

28. 060723a, P.I. A.N.8  
What is the total number of different four-letter arrangements that can be formed from the letters in the word "VERTICAL," if each letter is used only once in an arrangement?

[A] 8 [B] 6,720  
[C] 40,320 [D] 1,680

29. 080216a, P.I. G.G.30  
What is the measure of the largest angle in the accompanying triangle?

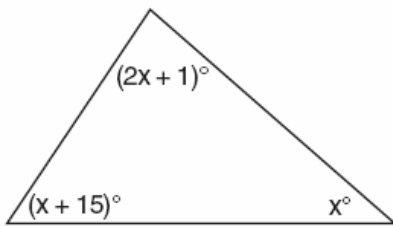

[A] 56 [B] 83 [C] 41 [D] 46.5

30. 010126a, P.I. A2.S.12  
Sal has a small bag of candy containing three green candies and two red candies. While waiting for the bus, he ate two candies out of the bag, one after another, without looking. What is the probability that both candies were the same color?

31. 060733a  
The perimeter of an isosceles triangle is 71 centimeters. The measure of one of the sides is 22 centimeters. What are all the possible measures of the other two sides?

32. 080219a, P.I. A.A.6  
If  $2x + 5 = -25$  and  $-3m - 6 = 48$ , what is the product of  $x$  and  $m$ ?

[A] -33 [B] 270 [C] 3 [D] -270

33. 060007a, P.I. A.A.10  
Which ordered pair is the solution of the following system of equations?

$$\begin{aligned} 3x + 2y &= 4 \\ -2x + 2y &= 24 \end{aligned}$$

[A] (-4,-8) [B] (-4,8)  
[C] (2,-5) [D] (2,-1)

34. 010335a, P.I. A.G.1  
On the accompanying set of axes, graph and label the following lines:

$$\begin{aligned} y &= 5 \\ x &= -4 \\ y &= \frac{5}{4}x + 5 \end{aligned}$$

Calculate the area, in square units, of the triangle formed by the three points of intersection.

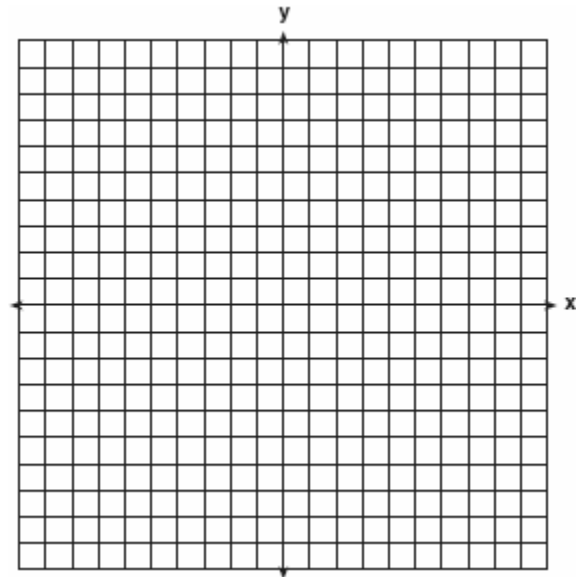

35. 089908a, P.I. A.M.2  
The formula  $C = \frac{5}{9}(F - 32)$  can be used to find the Celsius temperature ( $C$ ) for a given Fahrenheit temperature ( $F$ ). What Celsius temperature is equal to a Fahrenheit temperature of  $77^\circ$ ?

[A]  $8^\circ$  [B]  $25^\circ$  [C]  $171^\circ$  [D]  $45^\circ$

36. 060426a, P.I. A2.S.11  
In a game, each player receives 5 cards from a deck of 52 different cards. How many different groupings of cards are possible in this game?

[A]  $5!$     [B]  ${}_{52}C_5$     [C]  ${}_{52}P_5$     [D]  $\frac{52!}{5!}$

37. 080428a, P.I. G.G.36  
What is the sum, in degrees, of the measures of the interior angles of a stop sign, which is in the shape of an octagon?

[A] 1,880                      [B] 1,080  
[C] 1,440                      [D] 360

38. 060212a, P.I. G.G.22  
If point  $P$  lies on line  $\ell$ , which diagram represents the locus of points 3 centimeters from point  $P$ ?

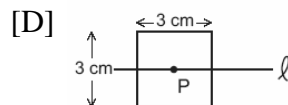
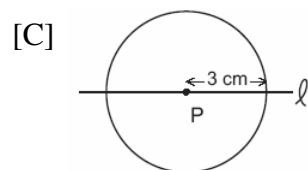
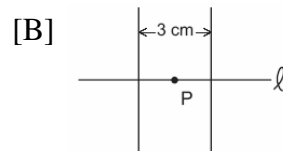
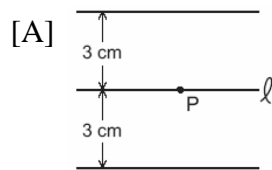

39. 080502a, P.I. A.N.7  
Cole's Ice Cream Stand serves sixteen different flavors of ice cream, three types of syrup, and seven types of sprinkles. If an ice cream sundae consists of one flavor of ice cream, one type of syrup, and one type of sprinkles, how many different ice cream sundaes can Cole serve?

[A] 336    [B] 10,836    [C] 26    [D] 3

40. 080413a, P.I. A.N.1  
Which equation illustrates the distributive property of multiplication over addition?

[A]  $6(3a + 4b) = 6(4b + 3a)$

[B]  $6(3a + 4b) = 18a + 24b$

[C]  $6(3a + 4b) = 18a + 4b$

[D]  $6(3a + 4b) = (3a + 4b)6$

41. 010104a, P.I. A.A.7  
Three times as many robins as cardinals visited a bird feeder. If a total of 20 robins and cardinals visited the feeder, how many were robins?

[A] 20    [B] 10    [C] 15    [D] 5

42. 010217a, P.I. A.N.1  
Which set is closed under division?

[A] integers                      [B] whole numbers

[C] counting numbers                      [D]  $\{1\}$

43. 060116a, P.I. A.N.5  
A boy got 50% of the questions on a test correct. If he had 10 questions correct out of the first 12, and  $\frac{1}{4}$  of the remaining questions correct, how many questions were on the test?

[A] 16    [B] 24    [C] 26    [D] 28

44. 060105a  
Which properties best describe the coordinate graph of two distinct parallel lines?  
[A] same slopes and different intercepts  
[B] different slopes and same intercepts  
[C] same slopes and same intercepts  
[D] different slopes and different intercepts

45. 010322a, P.I. A.N.5  
The world population was 4.2 billion people in 1982. The population in 1999 reached 6 billion. Find the percent of change from 1982 to 1999.

46. 080029a, P.I. A.N.5  
After an ice storm, the following headlines were reported in the *Glacier County Times*:  
Monday: Ice Storm Devastates County - 8 out of every 10 homes lose electrical power  
Tuesday: Restoration Begins - Power restored to  $\frac{1}{2}$  of affected homes  
Wednesday: More Freezing Rain - Power lost by 20% of homes that had power on Tuesday  
Based on these headlines, what fractional portion of homes in Glacier County had electrical power on Wednesday?

47. 080204a, P.I. A.N.7  
Juan has three blue shirts, two green shirts, seven red shirts, five pairs of denim pants, and two pairs of khaki pants. How many different outfits consisting of one shirt and one pair of pants are possible?  
[A] 19 [B] 84 [C] 130 [D] 420

48. 060615a, P.I. G.G.31  
The accompanying diagram shows the roof of a house that is in the shape of an isosceles triangle. The vertex angle formed at the peak of the roof is  $84^\circ$ .

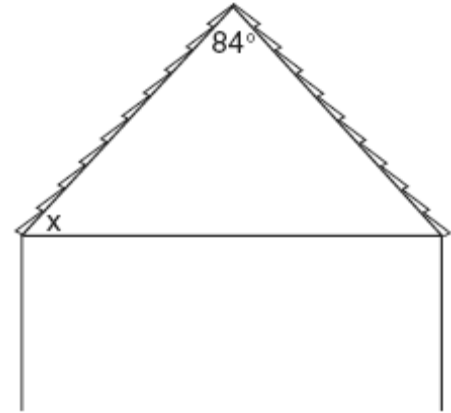

What is the measure of  $x$ ?

- [A]  $84^\circ$  [B]  $48^\circ$  [C]  $96^\circ$  [D]  $138^\circ$

49. 060603a, P.I. G.G.58  
One function of a movie projector is to enlarge the image on the film. This procedure is an example of a  
[A] translation [B] dilation  
[C] line reflection [D] line of symmetry

50. 010532a, P.I. G.G.58  
Fran's favorite photograph has a length of 6 inches and a width of 4 inches. She wants to have it made into a poster with dimensions that are similar to those of the photograph. She determined that the poster should have a length of 24 inches. How many inches wide will the poster be?

51. 010612a, P.I. A2.S.9  
Robin has 8 blouses, 6 skirts, and 5 scarves. Which expression can be used to calculate the number of different outfits she can choose, if an outfit consists of a blouse, a skirt, and a scarf?

- [A]  ${}_{19}C_3$  [B]  $8!6!5!$   
[C]  $8 \cdot 6 \cdot 5$  [D]  $8 + 6 + 5$

52. 010839a

On the accompanying set of axes, graph the parabola whose equation is  $y = x^2 - 2x - 8$  over the interval  $-3 \leq x \leq 5$  and graph the circle whose center is at  $(1, -5)$  and whose radius is 4. Using your graphs, determine how many points of intersection the two graphs have.

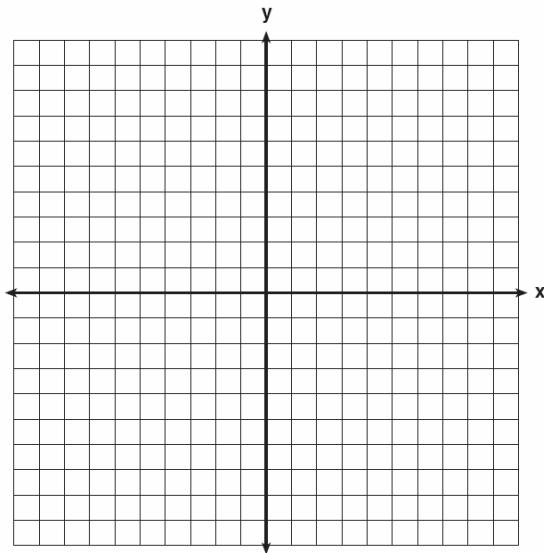

53. 010635a, P.I. A.A.6

A candy store sells 8-pound bags of mixed hazelnuts and cashews. If  $c$  pounds of cashews are in a bag, the price  $p$  of the bag can be found using the formula  $p = 2.59c + 1.72(8 - c)$ . If one bag is priced at \$18.11, how many pounds of cashews does it contain?

54. 080632a, P.I. A.A.26

Running at a constant speed, Andrea covers 15 miles in  $2\frac{1}{2}$  hours. At this speed, how many *minutes* will it take her to run 2 miles?

55. 080410a, P.I. 8.A.3

The accompanying graph shows the amount of water left in Rover's water dish over a period of time.

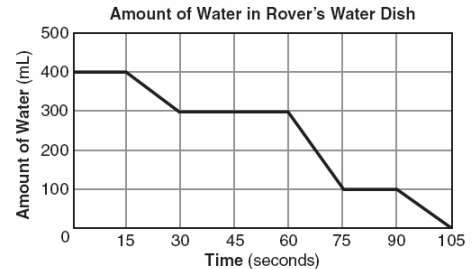

How long did Rover wait from the end of his first drink to the start of his second drink of water?

- [A] 60 sec                      [B] 10 sec  
[C] 75 sec                      [D] 30 sec

56. 080531a, P.I. A.A.45

The accompanying diagram shows a kite that has been secured to a stake in the ground with a 20-foot string. The kite is located 12 feet from the ground, directly over point X. What is the distance, in feet, between the stake and point X?

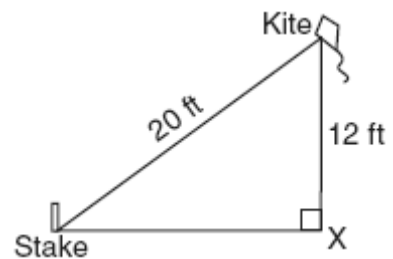

57. 080226a, P.I. A.RP.11

In a telephone survey of 100 households, 32 households purchased Brand A cereal and 45 purchased Brand B cereal. If 10 households purchased both items, how many of the households surveyed did *not* purchase either Brand A or Brand B cereal?



58. 010024a

A straight line with slope 5 contains the points  $(1,2)$  and  $(3,K)$ . Find the value of  $K$ .  
[The use of the accompanying grid is optional.]

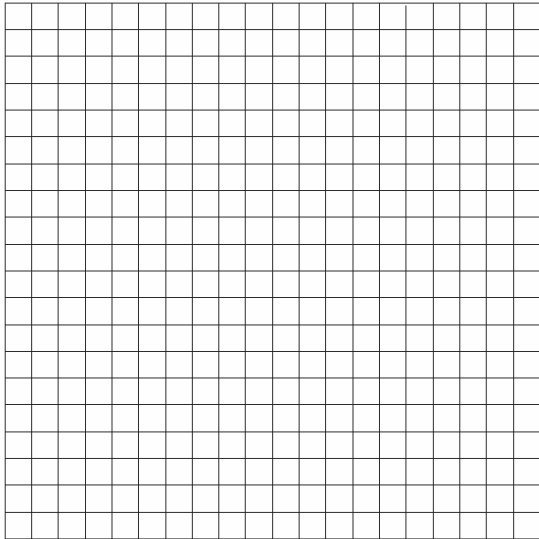

59. 010234a, P.I. A.G.7

A company manufactures bicycles and skateboards. The company's daily production of bicycles cannot exceed 10, and its daily production of skateboards must be less than or equal to 12. The combined number of bicycles and skateboards cannot be more than 16. If  $x$  is the number of bicycles and  $y$  is the number of skateboards, graph on the accompanying set of axes the region that contains the number of bicycles and skateboards the company can manufacture daily.

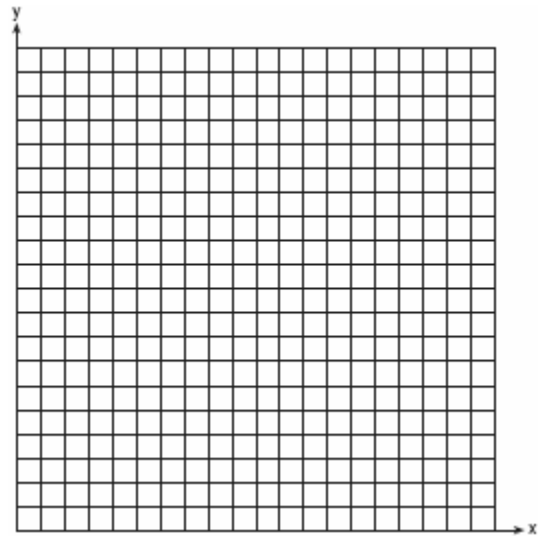

60. 010618a, P.I. 6.S.5

Melissa's test scores are 75, 83, and 75.  
Which statement is true about this set of data?

- [A] mean < mode      [B] mode < median  
[C] mode = median    [D] mean = median

61. 080602a, P.I. A.A.22

What is the value of  $p$  in the equation  $2(3p - 4) = 10$ ?

- [A] 1      [B]  $\frac{1}{3}$       [C]  $2\frac{1}{3}$       [D] 3

62. 080716a, P.I. A.A.1  
In the Ambrose family, the ages of the three children are three consecutive even integers. If the age of the youngest child is represented by  $x + 3$ , which expression represents the age of the oldest child?
- [A]  $x + 5$                       [B]  $x + 7$   
[C]  $x + 8$                       [D]  $x + 6$
63. 060409a, P.I. A.A.6  
At the beginning of her mathematics class, Mrs. Reno gives a warm-up problem. She says, "I am thinking of a number such that 6 less than the product of 7 and this number is 85." Which number is she thinking of?
- [A] 637    [B] 13    [C] 84    [D]  $11\frac{2}{7}$
64. 010722a  
If the measures of the angles of a triangle are represented by  $2x$ ,  $3x - 15$ , and  $7x + 15$ , the triangle is
- [A] an equiangular triangle  
[B] an isosceles triangle  
[C] a right triangle    [D] an acute triangle
65. 010035a, P.I. A.A.7  
The Excel Cable Company has a monthly fee of \$32.00 and an additional charge of \$8.00 for each premium channel. The Best Cable Company has a monthly fee of \$26.00 and additional charge of \$10.00 for each premium channel. The Horton family is deciding which of these two cable companies to subscribe to.
- a* For what number of premium channels will the total monthly subscription fee for the Excel and Best Cable companies be the same?  
*b* The Horton family decides to subscribe to 2 premium channels for a period of one year.
- (1) Which cable company should they subscribe to in order to spend less money?  
(2) How much money will the Hortons save in one year by using the less expensive company?
66. 080638a, P.I. 8.G.1  
 $\overline{AB}$  and  $\overline{CD}$  intersect at  $E$ . If  $m\angle AEC = 5x - 20$  and  $m\angle BED = x + 50$ , find, in degrees,  $m\angle CEB$ .
67. 080016a, P.I. A.N.3  
The expression  $2\sqrt{50} - \sqrt{2}$  is equivalent to
- [A]  $49\sqrt{2}$                       [B] 10  
[C]  $2\sqrt{48}$                       [D]  $9\sqrt{2}$
68. 060206a, P.I. A.A.20  
Which expression is a factor of  $n^2 + 3n - 54$ ?
- [A]  $n + 6$                       [B]  $n + 9$   
[C]  $n^2 + 9$                       [D]  $n - 9$
69. 060518a, P.I. A.A.12  
If  $x \neq 0$ , then  $\frac{(x^2)^3}{x^5} \cdot 1000$  is equivalent to
- [A] 0                                      [B]  $1000x$   
[C]  $1000 + x$                       [D] 1000

70. 010008a, P.I. A.A.12

The expression  $(x^2z^3)(xy^2z)$  is equivalent to

- [A]  $x^4y^2z^5$                       [B]  $x^3y^3z^4$   
[C]  $x^3y^2z^4$                       [D]  $x^2y^2z^3$

71. 060737a

Tracey has two empty cube-shaped containers with sides of 5 inches and 7 inches, as shown in the accompanying diagram. She fills the smaller container completely with water and then pours all the water from the smaller container into the larger container. How deep, to the *nearest tenth of an inch*, will the water be in the larger container?

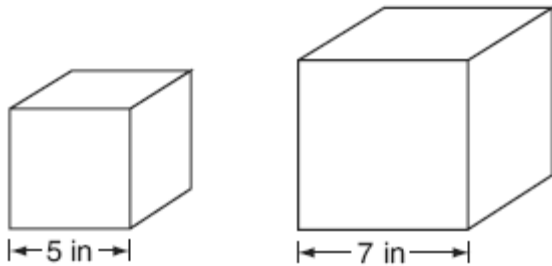

72. 080233a, P.I. A.A.7

Tanisha and Rachel had lunch at the mall. Tanisha ordered three slices of pizza and two colas. Rachel ordered two slices of pizza and three colas. Tanisha's bill was \$6.00, and Rachel's bill was \$5.25. What was the price of one slice of pizza? What was the price of one cola?

73. 010215a, P.I. A.A.27

What is the solution set of the equation  $3x^2 = 48$ ?

- [A]  $\{-2, -8\}$                       [B]  $\{2, 8\}$   
[C]  $\{4, -4\}$                       [D]  $\{4, 4\}$

74. 089929a

Line  $\ell$  contains the points  $(0,4)$  and  $(2,0)$ . Show that the point  $(-25,81)$  does or does not lie on line  $\ell$ .

75. 010424a, P.I. A2.S.11

Five people have volunteered to work on an awards dinner at Madison High School. How many different committees of four can be formed from the five people?

- [A] 20      [B] 1      [C] 5      [D] 10

76. 060201a, P.I. A.A.7

Jamie is 5 years older than her sister Amy. If the sum of their ages is 19, how old is Jamie?

- [A] 5      [B] 14      [C] 12      [D] 7

77. 010111a, P.I. 7.N.5

The distance from Earth to the Sun is approximately 93 million miles. A scientist would write that number as

- [A]  $9.3 \times 10^6$                       [B]  $93 \times 10^{10}$   
[C]  $93 \times 10^7$                       [D]  $9.3 \times 10^7$

78. 080405a, P.I. A.A.12

When  $-9x^5$  is divided by  $-3x^3$ ,  $x \neq 0$ , the quotient is

- [A]  $-27x^{15}$                       [B]  $-3x^2$   
[C]  $3x^2$                               [D]  $27x^8$

79. 010206a, P.I. 7.N.5

The approximate number of seconds in a year is 32,000,000. When this number is written in scientific notation, the numerical value of the exponent is

- [A] 7      [B] -7      [C] 6      [D] 8

80. 060529a, P.I. A.S.23

The probability that the Cubs win their first game is  $\frac{1}{3}$ . The probability that the Cubs win their second game is  $\frac{3}{7}$ . What is the probability that the Cubs win both games?

- [A]  $\frac{6}{7}$       [B]  $\frac{2}{5}$       [C]  $\frac{1}{7}$       [D]  $\frac{16}{21}$

81. 080202a, P.I. G.G.38

In the accompanying diagram of parallelogram  $ABCD$ , diagonals  $\overline{AC}$  and  $\overline{DB}$  intersect at  $E$ ,  $AE = 3x - 4$ , and  $EC = x + 12$ .

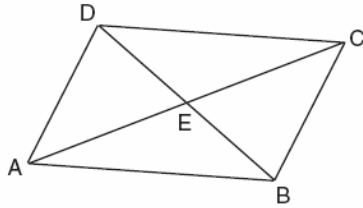

What is the value of  $x$ ?

- [A] 16    [B] 8    [C] 20    [D] 40

82. 080706a, P.I. A.A.10

If  $a + 3b = 13$  and  $a + b = 5$ , the value of  $b$  is

- [A] 4.5    [B] 4    [C] 7    [D] 1

83. 080629a, P.I. G.G.26

Which statement is logically equivalent to the statement "If Corey worked last summer, he buys a car"?

- [A] If Corey did not work last summer, he does not buy a car.  
[B] If Corey buys a car, he worked last summer.  
[C] If you are an elephant, then you forget.  
[D] If Corey does not buy a car, he did not work last summer.

84. 010027a, P.I. A.A.6

A truck traveling at a constant rate of 45 miles per hour leaves Albany. One hour later a car traveling at a constant rate of 60 miles per hour also leaves Albany traveling in the same direction on the same highway. How long will it take for the car to catch up to the truck, if both vehicles continue in the same direction on the highway?

85. 010514a, P.I. G.G.36

What is the sum, in degrees, of the measures of the interior angles of a pentagon?

- [A] 540    [B] 900    [C] 360    [D] 180

86. 060010a, P.I. A.A.6

A truck travels 40 miles from point  $A$  to point  $B$  in exactly 1 hour. When the truck is halfway between point  $A$  and point  $B$ , a car starts from point  $A$  and travels at 50 miles per hour. How many miles has the car traveled when the truck reaches point  $B$ ?

- [A] 40    [B] 25    [C] 60    [D] 50

87. 060725a, P.I. A.A.27

The solution set of the equation

$$x^2 - 4x - 12 = 0$$
 is

- [A]  $\{-3, 4\}$     [B]  $\{-6, 2\}$   
[C]  $\{-2, 6\}$     [D]  $\{-4, 3\}$

88. 080419a, P.I. A.RP.11

Seventy-eight students participate in one or more of three sports: baseball, tennis, and golf. Four students participate in all three sports; five play both baseball and golf, only; two play both tennis and golf, only; and three play both baseball and tennis, only. If seven students play only tennis and one plays only golf, what is the total number of students who play only baseball?

- [A] 56    [B] 12    [C] 60    [D] 44

89. 010103a, P.I. A2.A.13

If  $x > 0$ , the expression  $(\sqrt{x})(\sqrt{2x})$  is equivalent to

- [A]  $x^2\sqrt{2}$     [B]  $x\sqrt{2}$   
[C]  $\sqrt{2x}$     [D]  $2x$

90. 010113a, P.I. 7.A.10

Which equation could represent the relationship between the  $x$  and  $y$  values shown in the accompanying table?

$x$	$y$
0	2
1	3
2	6
3	11
4	18

- [A]  $y = 2^x$                       [B]  $y = x^2$   
 [C]  $y = x^2 + 2$                 [D]  $y = x + 2$

91. 080114a, P.I. A.N.5

In his will, a man leaves one-half of his money to his wife, one-half of what is then left to his older child, and one-half of what is then left to his younger child. His two cousins divide the remainder equally, each receiving \$2,000. What was the total amount of money in the man's will?

- [A] \$24,000                      [B] \$32,000  
 [C] \$16,000                      [D] \$40,000

92. 060613a, P.I. A.A.36

Which statement describes the graph of  $x = 4$ ?

- [A] It has a slope of 4.  
 [B] It passes through the point (0, 4).  
 [C] It is parallel to the  $y$ -axis.  
 [D] It is parallel to the  $x$ -axis.

93. 080434a, P.I. A2.A.7

Factor completely:  $3ax^2 - 27a$

94. 080134a, P.I. A.S.5

The following data consists of the weights, in pounds, of 30 adults:

195, 206, 100, 98, 150, 210, 195, 106, 195,  
 168, 180, 212, 104, 195, 100,  
 216, 195, 209, 112, 99, 206, 116, 195, 100,  
 142, 100, 135, 98, 160, 155

Using the data, complete the accompanying cumulative frequency table and construct a cumulative frequency histogram on the grid below.

Interval	Frequency	Cumulative Frequency
51–100		
101–150		
151–200		
201–250		

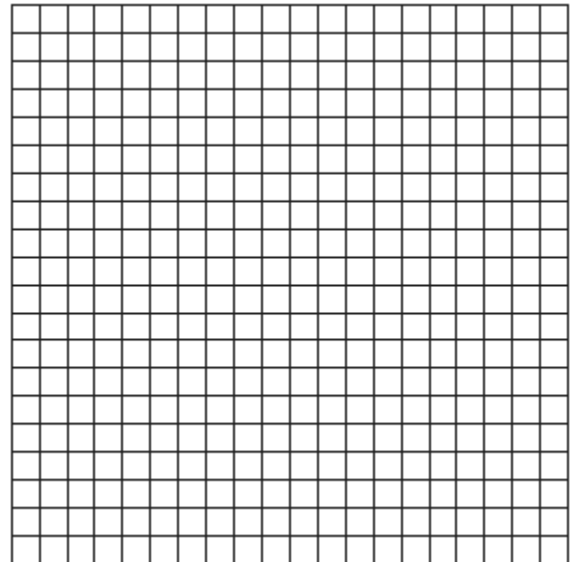

95. 060508a, P.I. G.G.56

A picture held by a magnet to a refrigerator slides to the bottom of the refrigerator, as shown in the accompanying diagram.

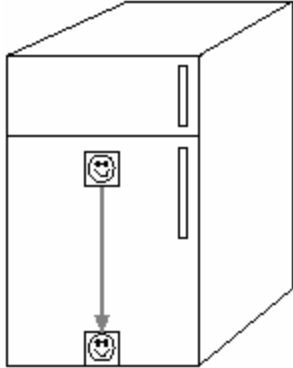

This change of position is an example of a

- [A] reflection            [B] rotation  
[C] translation        [D] dilation

96. 080530a, P.I. A.A.23

If  $\frac{x}{4} - \frac{a}{b} = 0$ ,  $b \neq 0$ , then  $x$  is equal to

- [A]  $\frac{a}{4b}$     [B]  $\frac{4a}{b}$     [C]  $-\frac{4a}{b}$     [D]  $-\frac{a}{4b}$

97. 080207a, P.I. A.A.17

The sum of  $\frac{3}{x} + \frac{2}{5}$ ,  $x \neq 0$ , is

- [A]  $\frac{2x+15}{x+5}$             [B]  $\frac{1}{x}$   
[C]  $\frac{5}{x+5}$               [D]  $\frac{2x+15}{5x}$

98. 060027a, P.I. G.G.31

Hersch says if a triangle is an obtuse triangle, then it cannot also be an isosceles triangle. Using a diagram, show that Hersch is incorrect, and indicate the measures of all the angles and sides to justify your answer.

99. 010533a, P.I. G.G.39

In rectangle  $ABCD$ ,  $AC = 3x + 15$  and  $BD = 4x - 5$ . Find the length of  $\overline{AC}$ .

100. 060432a, P.I. A.CM.5

Brett was given the problem: "Evaluate  $2x^2 + 5$  when  $x = 3$ ." Brett wrote that the answer was 41. Was Brett correct? Explain your answer.

101. 080621a, P.I. 7.N.3

Which list shows the numbers

$|-0.12|$ ,  $\sqrt{\frac{1}{82}}$ ,  $\frac{1}{8}$ ,  $\frac{1}{9}$  in order from smallest to largest?

[A]  $\sqrt{\frac{1}{82}}$ ,  $\frac{1}{9}$ ,  $|-0.12|$ ,  $\frac{1}{8}$

[B]  $|-0.12|$ ,  $\frac{1}{8}$ ,  $\frac{1}{9}$ ,  $\sqrt{\frac{1}{82}}$

[C]  $\sqrt{\frac{1}{82}}$ ,  $|-0.12|$ ,  $\frac{1}{9}$ ,  $\frac{1}{8}$

[D]  $\frac{1}{8}$ ,  $\frac{1}{9}$ ,  $\sqrt{\frac{1}{82}}$ ,  $|-0.12|$

102. 010836a, P.I. 8.G.3

In the accompanying diagram,  $\overline{BY}$  is a diameter of circle  $O$ , the measure of central angle  $ROY$  is  $(x + 60)^\circ$ , and the measure of central angle  $ROB$  is  $(3x - 20)^\circ$ . Find the number of degrees in the measure of central angle  $ROY$ .

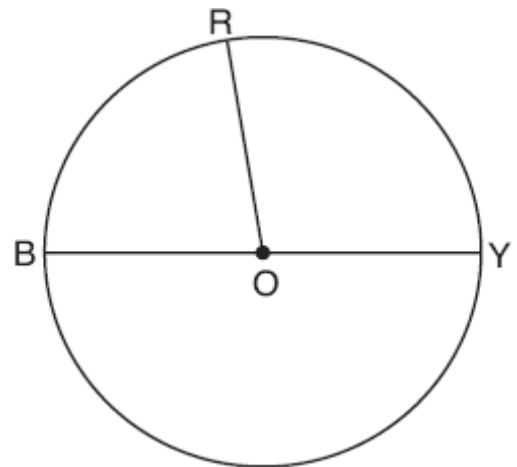

103. 010820a, P.I. A.A.1  
If  $x$  represents a given number, the expression "5 less than twice the given number" is written as

[A]  $5 < 2x$                       [B]  $2x - 5$   
[C]  $5 - 2x$                       [D]  $5 < 2 + x$

104. 060516a, P.I. G.G.37  
The accompanying figure represents a section of bathroom floor tiles shaped like regular hexagons.

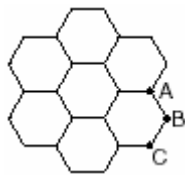

What is the measure of angle  $ABC$ ?

[A]  $150^\circ$                       [B]  $60^\circ$   
[C]  $90^\circ$                       [D]  $120^\circ$

105. 080001a, P.I. A.A.12  
The product of  $2x^3$  and  $6x^5$  is

[A]  $12x^8$                       [B]  $10x^{15}$   
[C]  $12x^{15}$                       [D]  $10x^8$

106. 060731a, P.I. A.M.2  
If a United States dollar is worth \$1.41 in Canadian money, how much is \$100 in Canadian money worth in United States money, to the *nearest cent*?

107. 060013a  
Which transformation does *not* always produce an image that is congruent to the original figure?

[A] dilation                      [B] translation  
[C] rotation                      [D] reflection

108. 060024a, P.I. G.G.45  
The Rivera family bought a new tent for camping. Their old tent had equal sides of 10 feet and a floor width of 15 feet, as shown in the accompanying diagram.

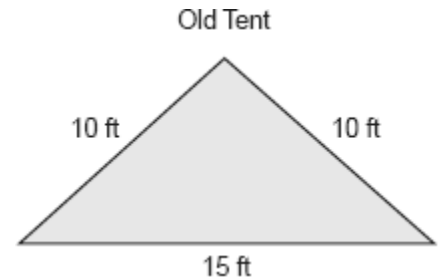

If the new tent is similar in shape to the old tent and has equal sides of 16 feet, how wide is the floor of the new tent?

109. 080538a, P.I. A.A.11  
Solve the following system of equations:

$$y = x^2 + 4x + 1$$

$$y = 5x + 3$$

[The use of the grid is optional.]

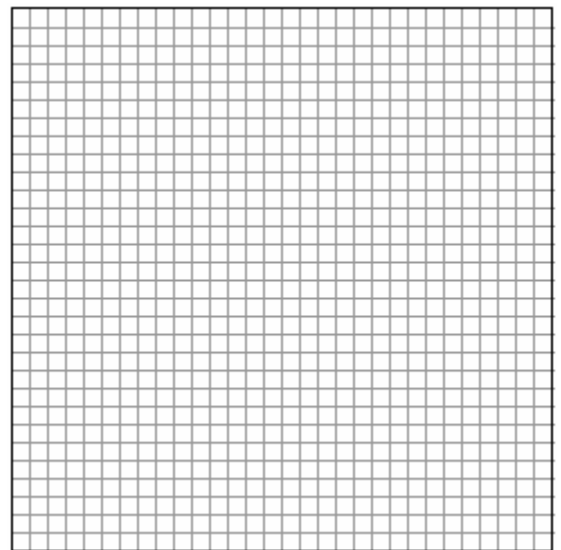

110. 060331a

Deborah built a box by cutting 3-inch squares from the corners of a rectangular sheet of cardboard, as shown in the accompanying diagram, and then folding the sides up. The volume of the box is 150 cubic inches, and the longer side of the box is 5 inches more than the shorter side. Find the number of inches in the shorter side of the *original* sheet of cardboard.

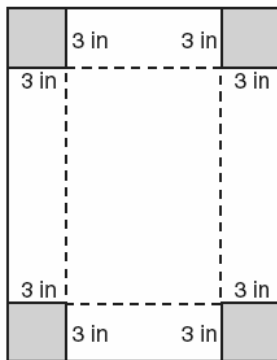

111. 069929a, P.I. A.A.6

The mean (average) weight of three dogs is 38 pounds. One of the dogs, Sparky, weighs 46 pounds. The other two dogs, Eddie and Sandy, have the same weight. Find Eddie's weight.

112. 060714a, P.I. A.N.1

Which property is illustrated by the equation

$$\frac{3}{2}x + 0 = \frac{3}{2}x?$$

[A] commutative property of addition

[B] additive identity property

[C] distributive property

[D] additive inverse property

113. 060425a, P.I. A.A.5

A farmer has a rectangular field that measures 100 feet by 150 feet. He plans to increase the area of the field by 20%. He will do this by increasing the length and width by the same amount,  $x$ . Which equation represents the area of the new field?

[A]  $2(100 + x) + 2(150 + x) = 15,000$

[B]  $(100 + x)(150 + x) = 18,000$

[C]  $(100 + x)(150 + x) = 15,000$

[D]  $(100 + 2x)(150 + x) = 18,000$

114. 060123a, P.I. A.A.7

Ben had twice as many nickels as dimes. Altogether, Ben had \$4.20. How many nickels *and* how many dimes did Ben have?

115. 010720a, P.I. A.N.1

If  $M$  and  $A$  represent integers,  $M + A = A + M$  is an example of which property?

[A] associative [B] closure

[C] commutative [D] distributive

116. 010229a, P.I. 8.G.1

In the accompanying diagram,  $\overline{AB}$  and  $\overline{CD}$  intersect at  $E$ . If  $m\angle AEC = 4x - 40$  and  $m\angle BED = x + 50$ , find the number of degrees in  $\angle AEC$ .

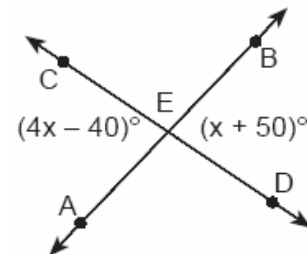

117. 010521a, P.I. G.G.42

If the midpoints of the sides of a triangle are connected, the area of the triangle formed is what part of the area of the original triangle?

[A]  $\frac{1}{3}$  [B]  $\frac{1}{4}$  [C]  $\frac{3}{8}$  [D]  $\frac{1}{2}$



118. 060106a, P.I. G.G.38  
Which statement is *not* always true about a parallelogram?
- [A] The opposite sides are parallel.  
[B] The diagonals are congruent.  
[C] The opposite angles are congruent.  
[D] The opposite sides are congruent.

119. 080415a, P.I. A.A.26  
A rocket car on the Bonneville Salt Flats is traveling at a rate of 640 miles per hour. How much time would it take for the car to travel 384 miles at this rate?
- [A] 256 minutes      [B] 36 minutes  
[C] 245 minutes      [D] 1.7 hours

120. 060111a, P.I. A.A.6  
If one-half of a number is 8 less than two-thirds of the number, what is the number?
- [A] 54      [B] 48      [C] 32      [D] 24

121. 080229a, P.I. A2.S.11  
On a bookshelf, there are five different mystery books and six different biographies. How many different sets of four books can Emilio choose if two of the books must be mystery books and two of the books must be biographies?

122. 060605a, P.I. A.N.6  
What is the value of  $\frac{8!}{4!}$ ?

[A] 4!      [B] 1,680      [C] 2!      [D] 2

123. 080711a, P.I. A.A.19  
One factor of the expression  $x^2y^2 - 16$  is
- [A]  $x^2 + 8$       [B]  $xy - 8$   
[C]  $xy - 4$       [D]  $x^2 - 4$

124. 080436a, P.I. A.N.5  
Walter is a waiter at the Towne Diner. He earns a daily wage of \$50, plus tips that are equal to 15% of the total cost of the dinners he serves. What was the total cost of the dinners he served if he earned \$170 on Tuesday?

125. 060230a, P.I. G.G.48  
In the accompanying diagram, triangle A is similar to triangle B. Find the value of  $n$ .

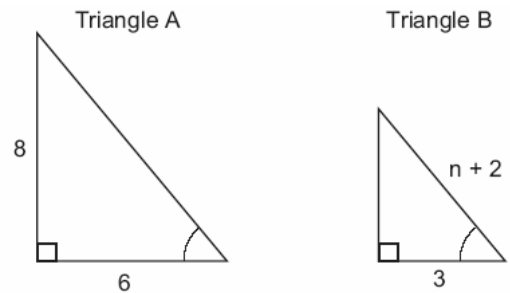

126. 069921a  
Draw all the symmetry lines on the accompanying figure.

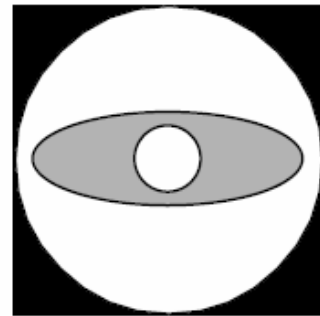

127. 060125a, P.I. A.N.8  
There were seven students running in a race. How many different arrangements of first, second, and third place are possible?

128. 010414a, P.I. A.A.19  
What is a common factor of  $x^2 - 9$  and  $x^2 - 5x + 6$ ?

[A]  $x - 2$       [B]  $x + 3$   
[C]  $x - 3$       [D]  $x^2$

129. 060631a, P.I. A.G.1  
Determine the area, in square feet, of the *smallest* square that can contain a circle with a radius of 8 feet.

130. 010613a, P.I. G.G.31  
In the accompanying diagram of  $\triangle ABC$ ,  $\overline{AB}$  is extended through  $D$ ,  $m\angle CBD = 30$ , and  $\overline{AB} \cong \overline{BC}$ .

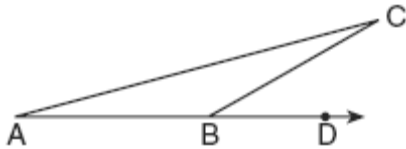

What is the measure of  $\angle A$ ?

- [A]  $30^\circ$  [B]  $150^\circ$  [C]  $75^\circ$  [D]  $15^\circ$
131. 080707a, P.I. A.A.45  
A cable 20 feet long connects the top of a flagpole to a point on the ground that is 16 feet from the base of the pole. How tall is the flagpole?  
[A] 10 ft [B] 12 ft [C] 26 ft [D] 8 ft
132. 080234a, P.I. A.A.27  
Greg is in a car at the top of a roller-coaster ride. The distance,  $d$ , of the car from the ground as the car descends is determined by the equation  $d = 144 - 16t^2$ , where  $t$  is the number of seconds it takes the car to travel down to each point on the ride. How many seconds will it take Greg to reach the ground?

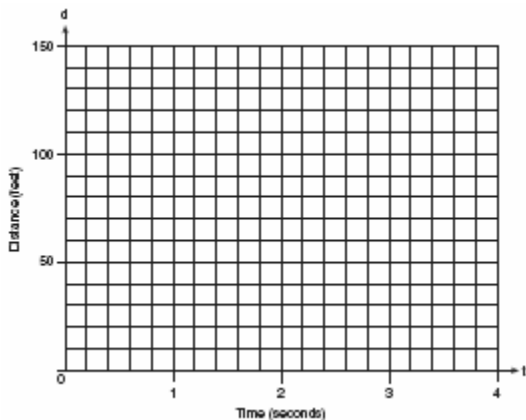

133. 010632a, P.I. 7.N.2  
Write an irrational number and explain why it is irrational.

134. 080512a, P.I. G.G.22  
Which equation represents the locus of all points 5 units below the  $x$ -axis?  
[A]  $x = 5$  [B]  $x = -5$   
[C]  $y = -5$  [D]  $y = 5$

135. 010011a, P.I. A.A.22  
If  $9x + 2a = 3a - 4x$ , then  $x$  equals  
[A]  $\frac{a}{13}$  [B]  $\frac{5a}{12}$  [C]  $a$  [D]  $-a$

136. 080732a, P.I. A.A.6  
Thelma and Laura start a lawn-mowing business and buy a lawnmower for \$225. They plan to charge \$15 to mow one lawn. What is the *minimum* number of lawns they need to mow if they wish to earn a profit of *at least* \$750?

137. 060332a, P.I. G.G.22  
A triangular park is formed by the intersection of three streets, Bridge Street, Harbor Place, and College Avenue, as shown in the accompanying diagram. A walkway parallel to Harbor Place goes through the park. A time capsule has been buried in the park in a location that is equidistant from Bridge Street and College Avenue and 5 yards from the walkway. Indicate on the diagram with an **X** *each* possible location where the time capsule could be buried.

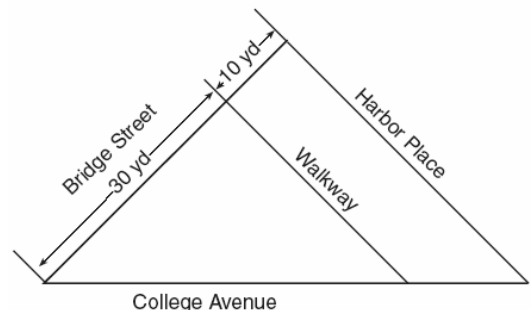

138. 080225a, P.I. A.N.5  
In bowling leagues, some players are awarded extra points called their "handicap." The "handicap" in Anthony's league is 80% of the difference between 200 and the bowler's average. Anthony's average is 145. What is Anthony's "handicap"?

139. 010216a, P.I. G.G.36  
In the accompanying diagram,  $\overline{ABCD}$  is a straight line, and angle  $E$  in triangle  $BEC$  is a right angle.

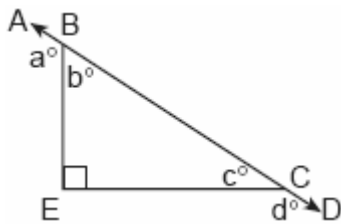

What does  $a^\circ + d^\circ$  equal?

- [A]  $135^\circ$                       [B]  $160^\circ$   
[C]  $180^\circ$                       [D]  $270^\circ$
140. 080103a, P.I. A2.A.7  
Written in simplest factored form, the binomial  $2x^2 - 50$  can be expressed as  
[A]  $2(x - 5)(x + 5)$       [B]  $2(x - 5)(x - 5)$   
[C]  $(x - 5)(x + 5)$       [D]  $2x(x - 50)$

141. 060128a, P.I. A.M.2  
Connor wants to compare Celsius and Fahrenheit temperatures by drawing a conversion graph. He knows that  $-40^\circ C = -40^\circ F$  and that  $20^\circ C = 68^\circ F$ . On the accompanying grid, construct the conversion graph and, using the graph, determine the Celsius equivalent of  $25^\circ F$ .

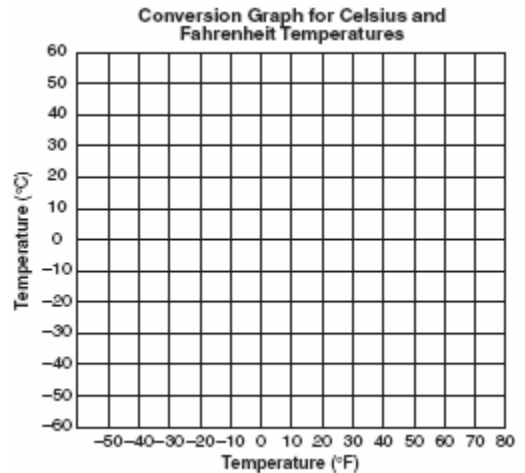

142. 060612a, P.I. A.A.26  
What is the value of  $x$  in the equation  
$$\frac{x}{2x+1} = \frac{4}{3} ?$$
  
[A]  $-\frac{5}{4}$       [B]  $-5$       [C]  $-\frac{4}{5}$       [D]  $-\frac{1}{5}$
143. 010717a, P.I. A.G.1  
A circular garden has a diameter of 12 feet. How many bags of topsoil must Linda buy to cover the garden if one bag covers an area of 3 square feet?  
[A] 13      [B] 38      [C] 40      [D] 151

144. 080615a, P.I. A.A.40  
Which ordered pair is in the solution set of the system of inequalities shown in the accompanying graph?

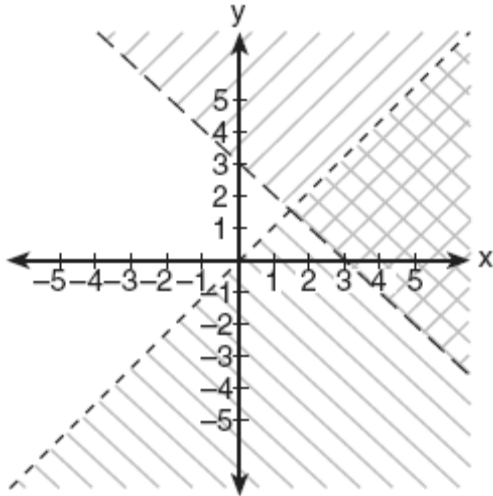

- [A] (0,1) [B] (1,5) [C] (3,2) [D] (0,0)

145. 010625a  
Which point is on the circle whose equation is  $x^2 + y^2 = 289$ ?

- [A] (7,-10) [B] (-1,-16)  
[C] (8,-15) [D] (-12,12)

146. 080622a, P.I. A.A.27  
One of the roots of the equation  $x^2 + 3x - 18 = 0$  is 3. What is the other root?  
[A] 15 [B] -21 [C] 6 [D] -6

147. 080217a  
 $M$  is the midpoint of  $\overline{AB}$ . If the coordinates of  $A$  are  $(-1,5)$  and the coordinates of  $M$  are  $(3,3)$ , what are the coordinates of  $B$ ?

- [A] (2,8) [B] (1,4)  
[C] (-5,7) [D] (7,1)

148. 010231a, P.I. A2.S.13  
A square dartboard is represented in the accompanying diagram. The entire dartboard is the first quadrant from  $x = 0$  to 6 and from  $y = 0$  to 6. A triangular region on the dartboard is enclosed by the graphs of the equations  $y = 2$ ,  $x = 6$ , and  $y = x$ . Find the probability that a dart that randomly hits the dartboard will land in the triangular region formed by the three lines.

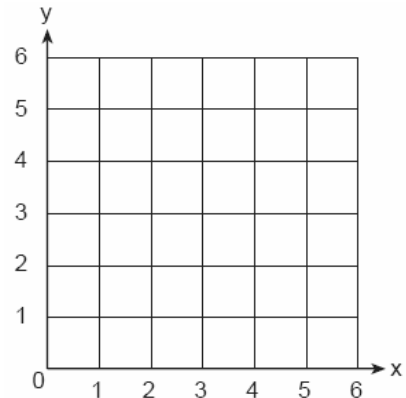

149. 010732a, P.I. A.N.5  
A 14-gram serving of mayonnaise contains 11 grams of fat. What percent of the mayonnaise, to the nearest tenth of a percent, is fat?
150. 010602a, P.I. G.G.56  
Ms. Brewer's art class is drawing reflected images. She wants her students to draw images reflected in a line. Which diagram represents a correctly drawn image?

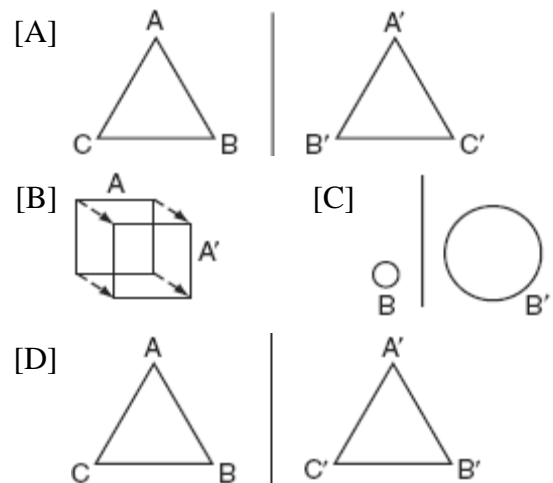

151. 060414a, P.I. 8.G.3  
The ratio of two supplementary angles is 2:7.  
What is the measure of the *smaller* angle?  
[A]  $20^\circ$  [B]  $40^\circ$  [C]  $14^\circ$  [D]  $10^\circ$
152. 010205a, P.I. A.A.12  
The product of  $3x^2y$  and  $-4xy^3$  is  
[A]  $-12x^2y^3$  [B]  $12x^3y^4$   
[C]  $12x^2y^3$  [D]  $-12x^3y^4$
153. 010539a, P.I. A.A.7  
The tickets for a dance recital cost \$5.00 for adults and \$2.00 for children. If the total number of tickets sold was 295 and the total amount collected was \$1,220, how many adult tickets were sold? [Only an algebraic solution can receive full credit.]

154. 060134a, P.I. A.G.1  
The plan of a parcel of land is represented by trapezoid  $ABCD$  in the accompanying diagram. If the area of  $\triangle ABE$  is 600 square feet, find the minimum number of feet of fence needed to completely enclose the entire parcel of land,  $ABCD$ .

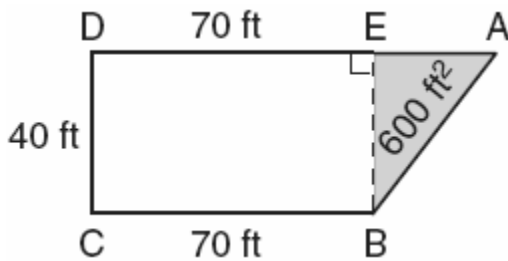

155. 060614a, P.I. G.G.25  
Given the statement: "If  $x$  is a rational number, then  $\sqrt{x}$  is irrational." Which value of  $x$  makes the statement *false*?  
[A] 3 [B] 2 [C] 4 [D]  $\frac{3}{2}$

156. 010814a, P.I. A.A.20  
What are the factors of  $x^2 - 5x + 6$ ?  
[A]  $(x + 6)$  and  $(x - 1)$   
[B]  $(x - 6)$  and  $(x + 1)$   
[C]  $(x - 2)$  and  $(x - 3)$   
[D]  $(x + 2)$  and  $(x + 3)$
157. 089934a, P.I. A.G.1  
Mr. Gonzalez owns a triangular plot of land  $BCD$  with  $DB = 25$  yards and  $BC = 16$  yards. He wishes to purchase the adjacent plot of land in the shape of right triangle  $ABD$ , as shown in the accompanying diagram, with  $AD = 15$  yards. If the purchase is made, what will be the total number of square yards in the area of his plot of land,  $\triangle ACD$ ?

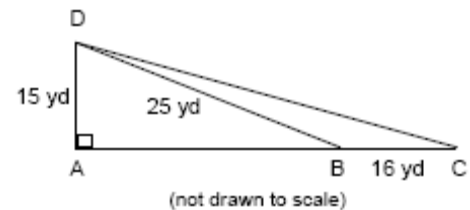

158. 010333a, P.I. G.G.54  
On the accompanying grid, draw and label quadrilateral  $ABCD$  with points  $A(1,2)$ ,  $B(6,1)$ ,  $C(7,6)$ , and  $D(3,7)$ . On the same set of axes, plot and label quadrilateral  $A'B'C'D'$ , the reflection of quadrilateral  $ABCD$  in the  $y$ -axis. Determine the area, in square units, of quadrilateral  $A'B'C'D'$ .

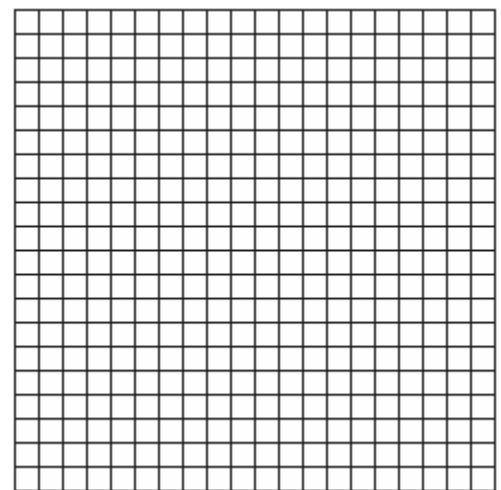

159. 060102a, P.I. A.A.14

Which polynomial is the quotient of

$$\frac{6x^3 + 9x^2 + 3x}{3x}?$$

- [A]  $2x + 3$                       [B]  $6x^2 + 9x$   
[C]  $2x^2 + 3x$                     [D]  $2x^2 + 3x + 1$

160. 080519a

Which letter demonstrates line symmetry but *not* point symmetry?

- [A] **H**    [B] **T**    [C] **S**    [D] **N**

161. 080232a, P.I. A.A.8

A rectangular park is three blocks longer than it is wide. The area of the park is 40 square blocks. If  $w$  represents the width, write an equation in terms of  $w$  for the area of the park. Find the length and the width of the park.

162. 080720a, P.I. A2.S.11

The expression  ${}_8C_3$  is equivalent to

- [A]  ${}_8P_5$     [B]  ${}_8C_5$     [C]  ${}_8P_3$     [D]  $\frac{8!}{3!}$

163. 010825a, P.I. A.A.26

If  $\frac{5}{n} - \frac{1}{2} = \frac{3}{6n}$ , what is the value of  $n$ ?

- [A] 2            [B] -2            [C]  $\frac{2}{7}$             [D] 9

164. 080705a, P.I. A2.S.7

The population growth of Boomtown is shown in the accompanying graph.

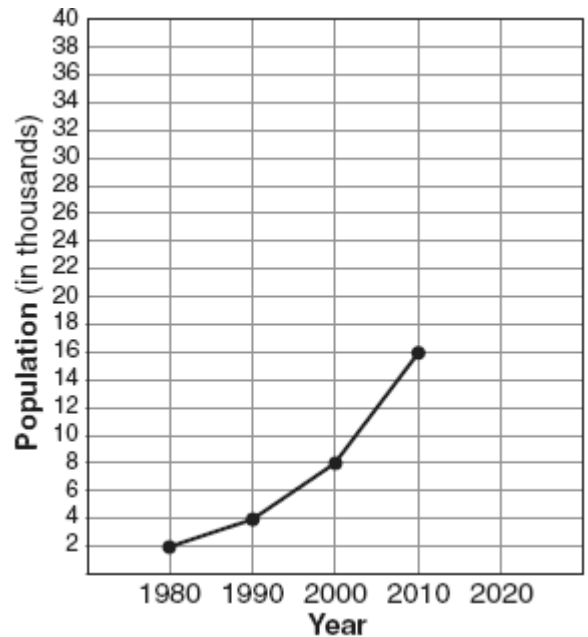

If the same pattern of population growth continues, what will the population of Boomtown be in the year 2020?

- [A] 32,000                      [B] 40,000  
[C] 64,000                      [D] 20,000

165. 010402a, P.I. 8.A.12

In the accompanying diagram, parallel lines  $\overline{AB}$  and  $\overline{CD}$  are intersected by transversal  $\overline{EF}$  at points  $G$  and  $H$ , respectively,  $m\angle AGH = x + 15$ , and  $m\angle GHD = 2x$ .

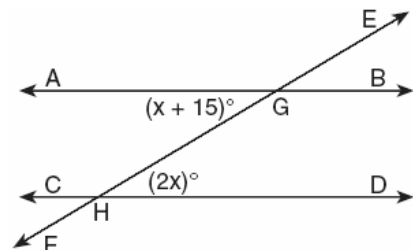

Which equation can be used to find the value of  $x$ ?

- [A]  $2x = x + 15$                       [B]  $2x + x + 15 = 90$   
[C]  $2x(x + 15) = 0$                     [D]  $2x + x + 15 = 180$

166. 089903a, P.I. G.G.56  
The transformation of  $\triangle ABC$  to  $\triangle AB'C'$  is shown in the accompanying diagram.

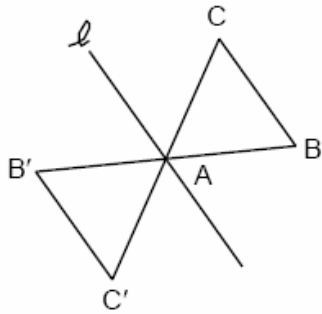

This transformation is an example of a

- [A] line reflection in line  $\ell$   
 [B] dilation [C] translation  
 [D] rotation about point A
167. 010837a, P.I. G.G.26  
In the spaces provided below, write the converse, the inverse, and the contrapositive of the statement "If I run, then I am tired."
- Converse: \_\_\_\_\_  
 \_\_\_\_\_
- Inverse: \_\_\_\_\_  
 \_\_\_\_\_
- Contrapositive: \_\_\_\_\_  
 \_\_\_\_\_

168. 080523a, P.I. 7.N.2  
Which is an irrational number?  
 [A]  $\pi$  [B]  $\sqrt{49}$  [C]  $0.\bar{3}$  [D]  $\frac{3}{8}$

169. 060722a, P.I. G.G.63  
Which statement describes the lines whose equations are  $y = \frac{1}{3}x + 12$  and  $6y = 2x + 6$ ?  
 [A] They are segments.  
 [B] They intersect each other.  
 [C] They are perpendicular to each other.  
 [D] They are parallel to each other.

170. 089930a, P.I. A.N.5  
A painting that regularly sells for a price of \$55 is on sale for 20% off. The sales tax on the painting is 7%. Will the final total cost of the painting differ depending on whether the salesperson deducts the discount before adding the sales tax or takes the discount after computing the sum of the original price and the sales tax on \$55?

171. 060104a, P.I. A2.A.7  
One root of the equation  $2x^2 - x - 15 = 0$  is  
 [A] 3 [B]  $\frac{3}{2}$  [C]  $\frac{5}{2}$  [D]  $-3$

172. 080109a, P.I. G.G.36  
The sum of the measures of the interior angles of an octagon is  
 [A]  $1,080^\circ$  [B]  $540^\circ$   
 [C]  $360^\circ$  [D]  $180^\circ$

173. 010827a, P.I. G.G.48  
Which set of numbers could be the lengths of the sides of a right triangle?  
 [A] {12,16,30} [B] {10,24,26}  
 [C] {4,7,8} [D] {3,4,6}

174. 060109a, P.I. A2.A.7  
Factor completely:  $3x^2 - 27$   
 [A]  $(3x + 3)(x - 9)$  [B]  $3(x - 3)^2$   
 [C]  $3(x^2 - 27)$  [D]  $3(x + 3)(x - 3)$

175. 010114a, P.I. A.N.8  
A locker combination system uses three digits from 0 to 9. How many different three-digit combinations with no digit repeated are possible?

[A] 720 [B] 504 [C] 30 [D] 1,000

176. 010032a, P.I. A.S.5  
In the time trials for the 400-meter run at the state sectionals, the 15 runners recorded the times shown in the table below.

400-Meter Run	
Time (sec)	Frequency
50.0–50.9	
51.0–51.9	
52.0–52.9	
53.0–53.9	
54.0–54.9	

a Using the data from the frequency column, draw a frequency histogram on the grid provided below.

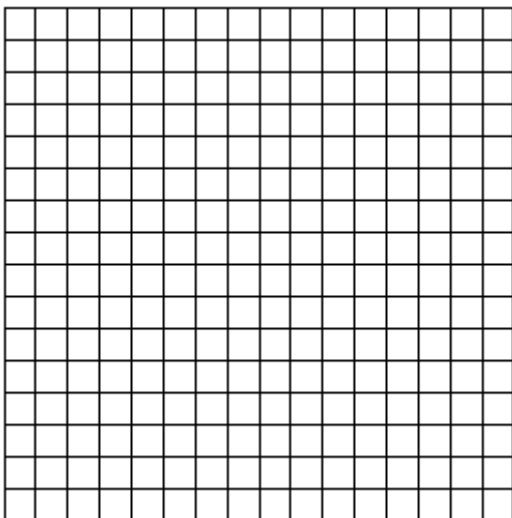

b What percent of the runners completed the time trial between 52.0 and 53.9 seconds?

177. 069931a, P.I. A.G.1  
A target shown in the accompanying diagram consists of three circles with the same center. The radii of the circles have lengths of 3 inches, 7 inches, and 9 inches.

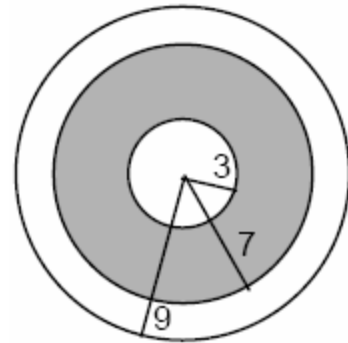

- a What is the area of the shaded region to the nearest tenth of a square inch?  
b To the nearest percent, what percent of the target is shaded?

178. 060129a, P.I. A.G.1  
Virginia has a circular rug on her square living room floor, as represented in the accompanying diagram. If her entire living room floor measures 100 square feet, what is the area of the part of the floor covered by the rug?

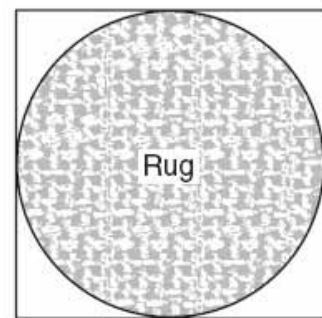

179. 080513a, P.I. A.A.21  
Which ordered pair is not in the solution set of  $y > 2x + 1$ ?  
[A] (1,6) [B] (1,4) [C] (3,8) [D] (2,5)



180. 060715a, P.I. 7.S.6  
In a recent poll in Syracuse, New York, 3,000 people were asked to pick their favorite baseball team. The accompanying circle graph shows the results of that poll.

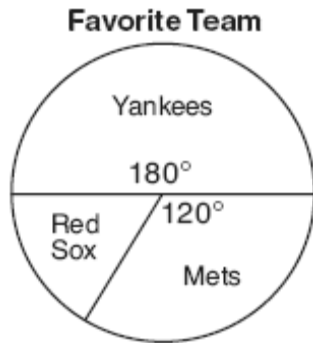

How many of the people polled picked the Red Sox as their favorite team?

- [A] 500 [B] 300 [C] 1,800 [D] 1,200
181. 060712a, P.I. A.S.20  
When a fair coin was tossed ten times, it landed heads up the first seven times. What is the probability that on the eighth toss the coin will land with tails up?
- [A]  $\frac{3}{7}$  [B]  $\frac{3}{10}$  [C]  $\frac{7}{10}$  [D]  $\frac{1}{2}$
182. 010131a, P.I. A.A.26

Solve algebraically for  $x$ :  $\frac{1}{x} = \frac{x+1}{6}$

183. 060410a, P.I. G.G.56  
Which type of transformation is illustrated in the accompanying diagram?

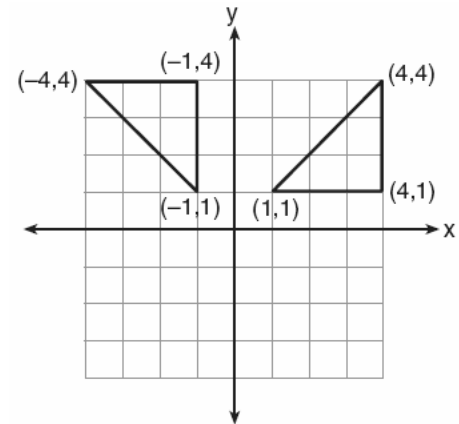

- [A] translation [B] dilation  
[C] reflection [D] rotation

184. 060524a, P.I. G.G.45  
On a scale drawing of a new school playground, a triangular area has sides with lengths of 8 centimeters, 15 centimeters, and 17 centimeters. If the triangular area located on the playground has a perimeter of 120 meters, what is the length of its longest side?
- [A] 24 m [B] 40 m  
[C] 45 m [D] 51 m
185. 080505a, P.I. G.G.25  
The statement " $x$  is divisible by 5 or  $x$  is divisible by 4" is *false* when  $x$  equals
- [A] 27 [B] 16 [C] 20 [D] 10

186. 060221a  
Given the true statement "John is not handsome" and the false statement "John is handsome or smart." Determine the truth value for the statement "John is smart."

187. 010134a, P.I. A.A.7

There were 100 more balcony tickets than main-floor tickets sold for a concert. The balcony tickets sold for \$4 and the main-floor tickets sold for \$12. The total amount of sales for both types of tickets was \$3,056.

a Write an equation or a system of equations that describes the given situation. Define the variables.

b Find the number of balcony tickets that were sold.

188. 010633a

In a circle whose center is (2,3), one endpoint of a diameter is (-1,5). Find the coordinates of the other endpoint of that diameter. [The use of the accompanying grid is optional.]

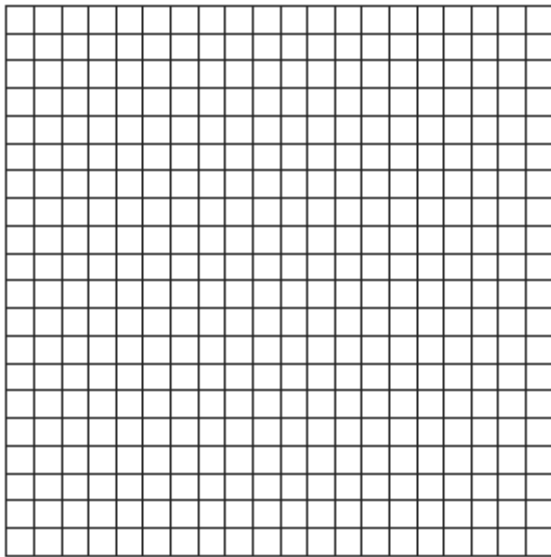

189. 080518a, P.I. A.A.6

A bicyclist leaves Bay Shore traveling at an average speed of 12 miles per hour. Three hours later, a car leaves Bay Shore, on the same route, traveling at an average speed of 30 miles per hour. How many hours after the car leaves Bay Shore will the car catch up to the cyclist?

- [A] 5      [B] 4      [C] 2      [D] 8

190. 089927a, P.I. A.A.43

A person standing on level ground is 2,000 feet away from the foot of a 420-foot-tall building, as shown in the accompanying diagram. To the *nearest degree*, what is the value of  $x$ ?

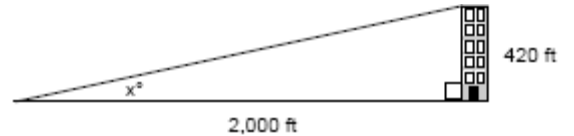

191. 060113a, P.I. 7.N.11

If  $a$  is an odd number,  $b$  an even number, and  $c$  an odd number, which expression will always be equivalent to an odd number?

- [A]  $a(bc)$                       [B]  $ac(b)^2$   
[C]  $ac(b)^1$                     [D]  $ac(b)^0$

192. 060030a, P.I. A.A.44

A surveyor needs to determine the distance across the pond shown in the accompanying diagram. She determines that the distance from her position to point  $P$  on the south shore of the pond is 175 meters and the angle from her position to point  $X$  on the north shore is  $32^\circ$ . Determine the distance,  $PX$ , across the pond, rounded to the *nearest meter*.

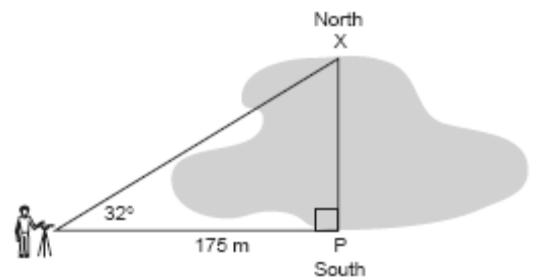

193. 080517a, P.I. G.G.39

In a certain quadrilateral, two opposite sides are parallel, and the other two opposite sides are *not* congruent. This quadrilateral could be a

- [A] trapezoid                    [B] rhombus  
[C] parallelogram              [D] square

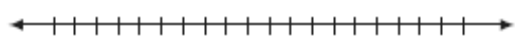
194. 080008a, P.I. A2.S.3  
On an English examination, two students received scores of 90, five students received 85, seven students received 75, and one student received 55. The average score on this examination was  
[A] 77 [B] 76 [C] 75 [D] 79
195. 060520a, P.I. G.G.26  
What is the converse of the statement "If it is Sunday, then I do not go to school"?  
[A] If I go to school, then it is not Sunday.  
[B] If I do not go to school, then it is Sunday.  
[C] If it is not Sunday, then I go to school.  
[D] If it is not Sunday, then I do not go to school.
196. 010526a, P.I. 7.N.3  
Which expression has the *smallest* value?  
[A]  $-3.02$  [B]  $-\pi$   
[C]  $-\frac{16}{5}$  [D]  $-\sqrt{10}$
197. 080532a, P.I. A.RP.11  
There are 30 students on a school bus. Of these students, 24 either play in the school band or sing in the chorus. Six of the students play in the school band but do not sing in the chorus. Fourteen of the students sing in the chorus and also play in the school band. How many students on the school bus sing in the chorus but do not play in the band?
198. 080535a, P.I. 6.S.5  
Seth bought a used car that had been driven 20,000 miles. After he owned the car for 2 years, the total mileage of the car was 49,400. Find the average number of miles he drove *each month* during those 2 years.
199. 080027a, P.I. A.G.1  
To measure the length of a hiking trail, a worker uses a device with a 2-foot-diameter wheel that counts the number of revolutions the wheel makes. If the device reads 1,100.5 revolutions at the end of the trail, how many miles long is the trail, to the *nearest tenth of a mile*?
200. 060404a, P.I. A.A.22  
If  $3(x - 2) = 2x + 6$ , the value of  $x$  is  
[A] 20 [B] 12 [C] 0 [D] 5
201. 080524a, P.I. A.N.3  
What is the sum of  $5\sqrt{7}$  and  $3\sqrt{28}$ ?  
[A]  $8\sqrt{35}$  [B]  $60\sqrt{7}$   
[C]  $9\sqrt{7}$  [D]  $11\sqrt{7}$
202. 060308a, P.I. G.G.26  
Which statement is logically equivalent to "If it is Saturday, then I am not in school"?  
[A] If it is not Saturday, then I am in school.  
[B] If I am in school, then it is not Saturday.  
[C] If I am not in school, then it is Saturday.  
[D] If it is Saturday, then I am in school.
203. 060532a, P.I. 8.G.19  
The manufacturer of Ron's car recommends that the tire pressure be at least 26 pounds per square inch and less than 35 pounds per square inch. On the accompanying number line, graph the inequality that represents the recommended tire pressure.
- 
204. 060403a, P.I. A.N.7  
How many different outfits consisting of a hat, a pair of slacks, and a sweater can be made from two hats, three pairs of slacks, and four sweaters?  
[A] 29 [B] 12 [C] 24 [D] 9

205. 060536a, P.I. A.A.8  
Mr. James wanted to plant a garden that would be in the shape of a rectangle. He was given 80 feet of fencing to enclose his garden. He wants the length to be 10 feet more than twice the width. What are the dimensions, in feet, for a rectangular garden that will use exactly 80 feet of fencing?

206. 010022a, P.I. A.A.7  
Mary and Amy had a total of 20 yards of material from which to make costumes. Mary used three times more material to make her costume than Amy used, and 2 yards of material was not used. How many yards of materials did Amy use for her costume?

207. 010135a, P.I. A.A.44  
Find, to the *nearest tenth of a foot*, the height of the tree represented in the accompanying diagram.

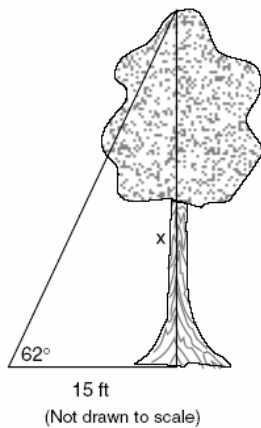

208. 010026a, P.I. A.A.6  
Judy needs a mean (average) score of 86 on four tests to earn a midterm grade of B. If the mean of her scores for the first three tests was 83, what is the *lowest* score on a 100-point scale that she can receive on the fourth test to have a midterm grade of B?

209. 060628a  
What is the sum of  $6 \times 10^3$  and  $3 \times 10^2$  ?  
[A]  $6.3 \times 10^3$  [B]  $18 \times 10^5$   
[C]  $9 \times 10^6$  [D]  $9 \times 10^5$

210. 080626a, P.I. A2.S.11  
In the next Olympics, the United States can enter four athletes in the diving competition. How many different teams of four divers can be selected from a group of nine divers?  
[A] 36 [B] 126 [C] 6,561 [D] 3,024

211. 080435a, P.I. 7.S.6  
The accompanying circle graph shows the favorite colors of the 300 students in the ninth grade. How many students chose red as their favorite color?

Favorite Colors

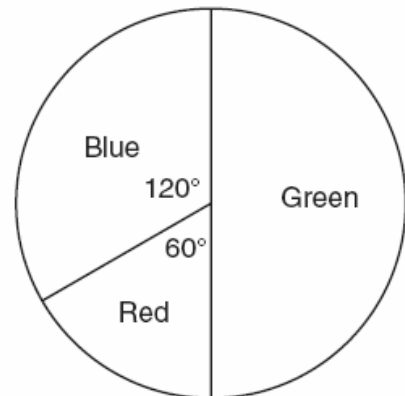

212. 010425a, P.I. A.A.24  
The inequality  $\frac{1}{2}x + 3 < 2x - 6$  is equivalent to  
[A]  $x < 6$  [B]  $x > 6$   
[C]  $x > -\frac{5}{6}$  [D]  $x < -\frac{5}{6}$

213. 010312a, P.I. 8.A.13

Which graph represents the solution set for  $2x - 4 \leq 8$  and  $x + 5 \geq 7$ ?

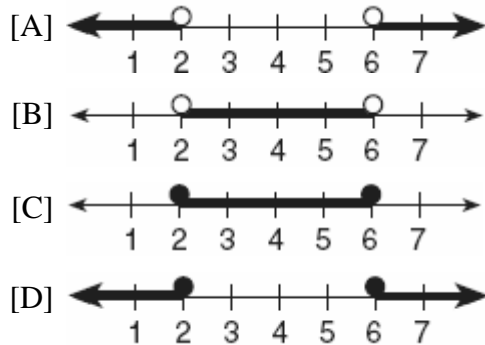

214. 010412a, P.I. 8.A.3

John left his home and walked 3 blocks to his school, as shown in the accompanying graph.

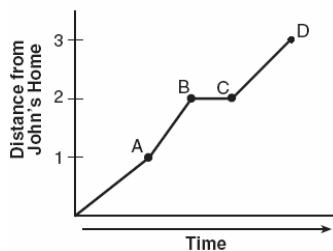

What is one possible interpretation of the section of the graph from point  $B$  to point  $C$ ?

- [A] John waited before crossing a busy street.
- [B] John reached the top of a hill and began walking on level ground.
- [C] John arrived at school and stayed throughout the day.
- [D] John returned home to get his mathematics homework.

215. 010715a, P.I. G.G.26

What is the inverse of the statement "If Bob gets hurt, then the team loses the game"?

- [A] Bob gets hurt if the team loses the game.
- [B] If the team does not lose the game, then Bob does not get hurt.
- [C] If the team loses the game, then Bob gets hurt.
- [D] If Bob does not get hurt, then the team does not lose the game.

216. 080627a, P.I. A.A.8

When Albert flips open his mathematics textbook, he notices that the product of the page numbers of the two facing pages that he sees is 156. Which equation could be used to find the page numbers that Albert is looking at?

- [A]  $(x + 1) + (x + 2) = 156$
- [B]  $x + (x + 1) = 156$
- [C]  $(x + 1)(x + 3) = 156$
- [D]  $x(x + 1) = 156$

217. 060416a, P.I. G.G.25

The statement " $x$  is *not* the square of an integer and  $x$  is a multiple of 3" is true when  $x$  is equal to

- [A] 9      [B] 32      [C] 36      [D] 18

218. 080131a, P.I. G.G.22

Point  $P$  is located on  $\overline{AB}$ .

$a$  Describe the locus of points that are

- (1) 3 units from  $\overline{AB}$
- (2) 5 units from point  $P$

$b$  How many points satisfy both conditions in part  $a$ ?

219. 010128a, P.I. 8.G.3  
In the accompanying figure, two lines intersect,  $m\angle 3 = 6t + 30$ , and  $m\angle 2 = 8t - 60$ . Find the number of degrees in  $m\angle 4$ .

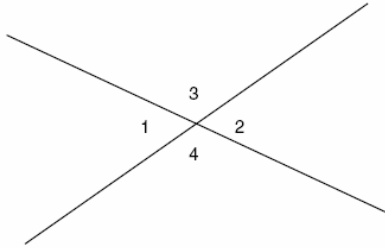

220. 060633a  
Two hikers started at the same location. One traveled 2 miles east and then 1 mile north. The other traveled 1 mile west and then 3 miles south. At the end of their hikes, how many miles apart are the two hikers? [The use of the accompanying grid is optional.]

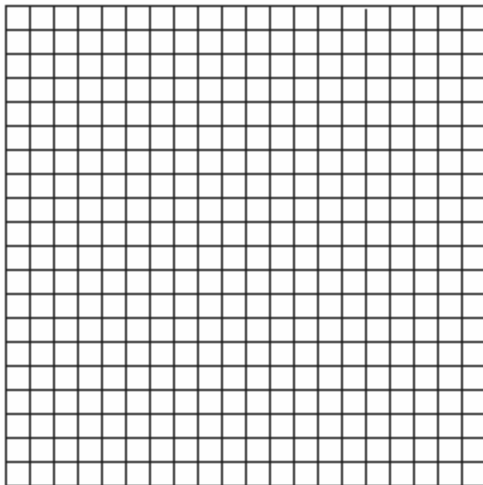

221. 080715a, P.I. 7.N.5  
The video of the movie *Star Wars* earned \$193,500,000 in rental fees during its first year. Expressed in scientific notation, the number of dollars earned is
- [A]  $1.935 \times 10^6$       [B]  $1935 \times 10^8$   
[C]  $193.5 \times 10^6$       [D]  $1.935 \times 10^8$

222. 010204a, P.I. A.A.22  
What is the value of  $x$  in the equation  $\frac{3}{4}x + 2 = \frac{5}{4}x - 6$ ?
- [A] -16    [B] 16    [C] 4    [D] -4

223. 060421a, P.I. A.A.20  
If  $3x$  is one factor of  $3x^2 - 9x$ , what is the other factor?
- [A]  $x + 3$       [B]  $x - 3$   
[C]  $3x$       [D]  $x^2 - 6x$

224. 080521a, P.I. G.G.26  
What is the converse of the statement "If Alicia goes to Albany, then Ben goes to Buffalo"?
- [A] If Ben does not go to Buffalo, then Alicia does not go to Albany.  
[B] Alicia goes to Albany if and only if Ben goes to Buffalo.  
[C] If Alicia does not go to Albany, then Ben does not go to Buffalo.  
[D] If Ben goes to Buffalo, then Alicia goes to Albany.

225. 089917a, P.I. A.N.8  
How many different 6-letter arrangements can be formed using the letters in the word "ABSENT," if each letter is used only once?
- [A] 36    [B] 720    [C] 6    [D] 46,656

226. 010324a  
A fish tank with a rectangular base has a volume of 3,360 cubic inches. The length and width of the tank are 14 inches and 12 inches, respectively. Find the height, in inches, of the tank.

227. 060205a, P.I. A.A.37  
What is the slope of the linear equation  $5y - 10x = -15$ ?
- [A] -10    [B] 2    [C] 10    [D] -15

228. 060402a, P.I. G.G.61  
What is the image of  $(x, y)$  after a translation of 3 units right and 7 units down?

[A]  $(x + 3, y + 7)$       [B]  $(x - 3, y + 7)$   
[C]  $(x + 3, y - 7)$       [D]  $(x - 3, y - 7)$

229. 010631a, P.I. A.A.16

Simplify:  $\frac{x^2 + 6x + 5}{x^2 - 25}$

230. 080606a, P.I. A.A.7  
Sal keeps quarters, nickels, and dimes in his change jar. He has a total of 52 coins. He has three more quarters than dimes and five fewer nickels than dimes. How many dimes does Sal have?

[A] 20      [B] 18      [C] 13      [D] 21

231. 060511a, P.I. A.A.13  
The expression  $(x^2 - 5x - 2) - (-6x^2 - 7x - 3)$  is equivalent to

[A]  $7x^2 - 2x + 1$       [B]  $7x^2 + 2x - 5$   
[C]  $7x^2 - 12x - 5$       [D]  $7x^2 + 2x + 1$

232. 010028a, P.I. A.G.1  
In the figure below, the large rectangle,  $ABCD$ , is divided into four smaller rectangles. The area of rectangle  $AEHG = 5x$ , the area of rectangle  $GHFB = 2x^2$ , the area of rectangle  $HJCF = 6x$ , segment  $AG = 5$ , and segment  $AE = x$ .

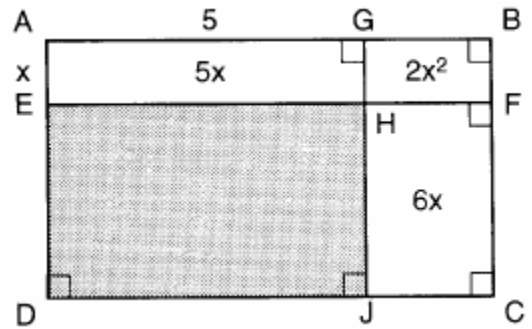

- a Find the area of the shaded region.  
b Write an expression for the area of the rectangle  $ABCD$  in terms of  $x$ .

233. 069933a, P.I. G.G.40  
The cross section of an attic is in the shape of an isosceles trapezoid, as shown in the accompanying figure. If the height of the attic is 9 feet,  $BC = 12$  feet, and  $AD = 28$  feet, find the length of  $\overline{AB}$  to the nearest foot.

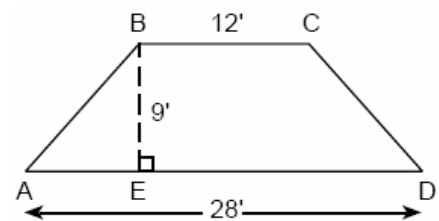

234. 010806a, P.I. A.N.5  
If  $x$  varies directly as  $y$ , and  $x = 8$  when  $y = 24$ , what is the value of  $x$  when  $y = 6$ ?

[A] 1      [B] 3      [C] 4      [D] 2

235. 069907a, P.I. A2.S.11  
How many different three-member teams can be formed from six students?

[A] 20      [B] 216      [C] 120      [D] 720

236. 060523a, P.I. A.A.36

Which graph represents the equation  $x = 2$ ?

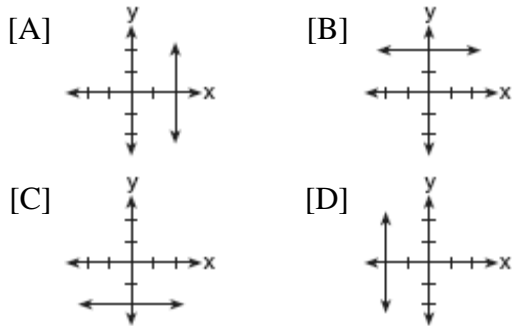

237. 060424a, P.I. A.N.1

Which expression is an example of the associative property?

- [A]  $x(y + z) = xy + xz$   
 [B]  $(x + y) + z = x + (y + z)$   
 [C]  $x \cdot 1 = x$       [D]  $x + y + z = z + y + x$

238. 060602a, P.I. A.A.22

What is the value of  $x$  in the equation  $13x - 2(x + 4) = 8x + 1$ ?

- [A] 2      [B] 3      [C] 1      [D] 4

239. 080439a, P.I. A.A.26

Solve for all values of  $x$  that satisfy the equation  $\frac{x}{x+3} = \frac{5}{x+7}$ .

240. 069916a, P.I. A.G.1

In the accompanying figure,  $ACDH$  and  $BCEF$  are rectangles,  $AH = 2$ ,  $GH = 3$ ,  $GF = 4$ , and  $FE = 5$ .

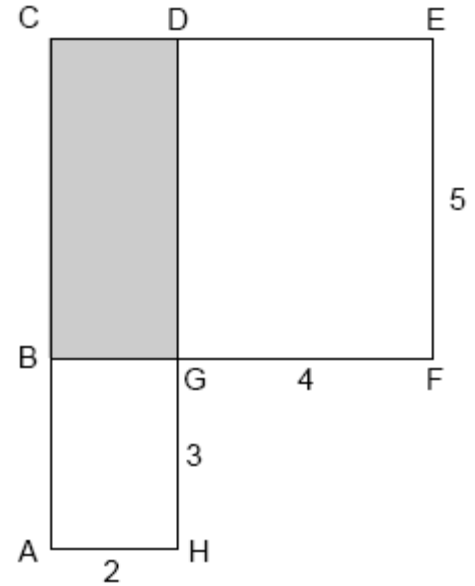

What is the area of  $BCDG$ ?

- [A] 6      [B] 8      [C] 20      [D] 10

241. 080620a, P.I. A.A.22

What is the value of  $w$  in the equation

$$\frac{3}{4}w + 8 = \frac{1}{3}w - 7?$$

- [A] -36      [B] 2.4      [C] -13.846      [D] -0.2



242. 010611a, P.I. 7.S.6

The accompanying circle graph shows how Shannon earned \$600 during her summer vacation.



What is the measure of the central angle of the section labeled "Chores"?

- [A]  $120^\circ$  [B]  $30^\circ$  [C]  $90^\circ$  [D]  $60^\circ$

243. 010634a, P.I. A2.S.13

The accompanying diagram shows a square dartboard. The side of the dartboard measures 30 inches. The square shaded region at the center has a side that measures 10 inches. If darts thrown at the board are equally likely to land anywhere on the board, what is the theoretical probability that a dart does *not* land in the shaded region?

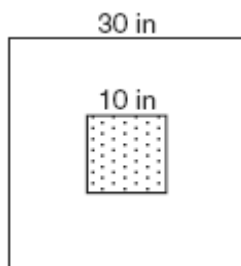

244. 080616a, P.I. A.N.8

Julia has four different flags that she wants to hang on the wall of her room. How many different ways can the flags be arranged in a row?

- [A] 16 [B] 1 [C] 24 [D] 10

245. 010712a, P.I. A.A.1

Which expression represents the product of two consecutive odd integers, where  $n$  is an odd integer?

- [A]  $n(n + 2)$  [B]  $2n + 1$   
[C]  $n(n + 1)$  [D]  $n(n + 3)$

246. 060316a, P.I. A.N.3

The sum of  $\sqrt{18}$  and  $\sqrt{72}$  is

- [A]  $\sqrt{90}$  [B]  $6\sqrt{3}$   
[C]  $9\sqrt{2}$  [D]  $3\sqrt{10}$

247. 080104a, P.I. G.G.26

Which statement is logically equivalent to "If I did not eat, then I am hungry"?

- [A] If I did not eat, then I am not hungry.  
[B] If I am not hungry, then I did eat.  
[C] If I am hungry, then I did eat.  
[D] If I am not hungry, then I did not eat.

248. 080031a, P.I. A.G.1

Mr. Santana wants to carpet exactly half of his rectangular living room. He knows that the perimeter of the room is 96 feet and that the length of the room is 6 feet longer than the width. How many square feet of carpeting does Mr. Santana need?

249. 080423a, P.I. A.A.13

The expression  $(3x^2 + 2xy + 7) - (6x^2 - 4xy + 3)$  is equivalent to

- [A]  $3x^2 - 6xy - 4$  [B]  $3x^2 - 2xy + 4$   
[C]  $-3x^2 + 6xy + 4$  [D]  $-3x^2 - 2xy + 4$

250. 060621a, P.I. 8.G.3

The measures of two complementary angles are represented by  $(3x + 15)$  and  $(2x - 10)$ . What is the value of  $x$ ?

- [A] 19 [B] 17 [C] 37 [D] 35

251. 080122a, P.I. A.A.45  
How many feet from the base of a house must a 39-foot ladder be placed so that the top of the ladder will reach a point on the house 36 feet from the ground?

252. 069919a, P.I. A.RP.11  
In a class of 50 students, 18 take music, 26 take art, and 2 take both art and music. How many students in the class are not enrolled in either music or art?

- [A] 8      [B] 16      [C] 24      [D] 6

253. 080205a, P.I. G.G.26  
Given the statement: "If two lines are cut by a transversal so that the corresponding angles are congruent, then the lines are parallel."  
What is true about the statement and its converse?

- [A] The statement and its converse are both true.  
[B] The statement and its converse are both false.  
[C] The statement is false, but its converse is true.  
[D] The statement is true, but its converse is false.

254. 010502a, P.I. 8.G.4  
In the accompanying diagram, lines  $a$  and  $b$  are parallel, and lines  $c$  and  $d$  are transversals.

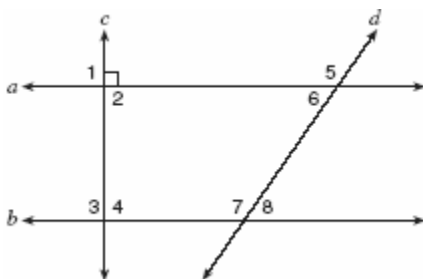

Which angle is congruent to angle 8?

- [A] 4      [B] 5      [C] 6      [D] 3

255. 069911a, P.I. A.A.12  
The expression  $2^3 \cdot 4^2$  is equivalent to

- [A]  $2^7$       [B]  $8^6$       [C]  $2^{12}$       [D]  $8^5$

256. 010438a, P.I. A.A.43  
In the accompanying diagram, the base of a 15-foot ladder rests on the ground 4 feet from a 6-foot fence.

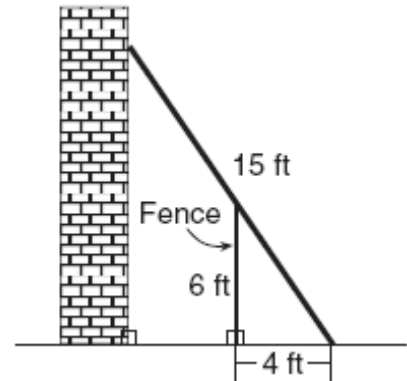

$a$  If the ladder touches the top of the fence and the side of a building, what angle, to the nearest degree, does the ladder make with the ground?

$b$  Using the angle found in part  $a$ , determine how far the top of the ladder reaches up the side of the building, to the nearest foot.

257. 060401a, P.I. A.S.9

The test scores for 10 students in Ms. Sampson's homeroom were 61, 67, 81, 83, 87, 88, 89, 90, 98, and 100. Which frequency table is accurate for this set of data?

[A]

Interval	Frequency
61–70	2
71–80	2
81–90	7
91–100	10

[B]

Interval	Frequency
61–70	2
71–80	0
81–90	8
91–100	10

[C]

Interval	Frequency
61–70	2
71–80	0
81–90	6
91–100	2

[D]

Interval	Frequency
61–70	2
71–80	2
81–90	8
91–100	10

258. 010819a, P.I. A.A.13

What is the product of  $2r^2 - 5$  and  $3r$ ?

- [A]  $6r^2 - 15$                       [B]  $6r^2 - 15r$   
 [C]  $6r^3 - 5$                         [D]  $6r^3 - 15r$

259. 010101a, P.I. A.A.6

There are 461 students and 20 teachers taking buses on a trip to a museum. Each bus can seat a maximum of 52. What is the *least* number of buses needed for the trip?

- [A] 8      [B] 9      [C] 11      [D] 10

260. 060438a, P.I. A.A.6

On the first six tests in her social studies course, Jerelyn's scores were 92, 78, 86, 92, 95, and 91. Determine the median and the mode of her scores. If Jerelyn took a seventh test and raised the mean of her scores exactly 1 point, what was her score on the seventh test?

261. 060531a, P.I. A.A.7

A ribbon 56 centimeters long is cut into two pieces. One of the pieces is three times longer than the other. Find the lengths, in centimeters, of both pieces of ribbon.

262. 080618a, P.I. G.G.38

The measures of two consecutive angles of a parallelogram are in the ratio 5:4. What is the measure of an obtuse angle of the parallelogram?

- [A]  $100^\circ$     [B]  $20^\circ$     [C]  $80^\circ$     [D]  $160^\circ$

263. 010309a

Line  $P$  and line  $C$  lie on a coordinate plane and have equal slopes. Neither line crosses the second or third quadrant. Lines  $P$  and  $C$  must

- [A] be horizontal            [B] be vertical  
 [C] form an angle of  $45^\circ$   
 [D] be perpendicular

264. 010529a, P.I. A.A.12

Expressed in its simplest form,  $(3x^3)(2y)^2(4x^4)$  is equivalent to

- [A]  $48x^{12}y^2$                       [B]  $24x^7y^2$   
 [C]  $24x^{12}y^2$                       [D]  $48x^7y^2$

265. 010320a, P.I. 8.G.4

In the accompanying figure, what is one pair of alternate interior angles?

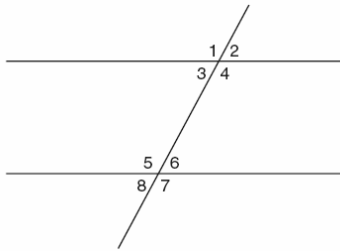

- [A]  $\angle 1$  and  $\angle 2$       [B]  $\angle 4$  and  $\angle 5$   
[C]  $\angle 6$  and  $\angle 8$       [D]  $\angle 4$  and  $\angle 6$

266. 080117a, P.I. A.RP.11

In a class of 450 students, 300 are taking a mathematics course and 260 are taking a science course. If 140 of these students are taking both courses, how many students are not taking either of these courses?

- [A] 140    [B] 40    [C] 30    [D] 110

267. 060020a, P.I. A2.A.8

What is the value of  $3^{-2}$ ?

- [A]  $\frac{1}{9}$       [B]  $-\frac{1}{9}$       [C] -9    [D] 9

268. 010315a, P.I. 6.S.5

The ages of five children in a family are 3, 3, 5, 8, and 18. Which statement is true for this group of data?

- [A] median  $>$  mean    [B] mode  $>$  mean  
[C] median = mode    [D] mean  $>$  median

269. 060115a, P.I. A.A.45

A woman has a ladder that is 13 feet long. If she sets the base of the ladder on level ground 5 feet from the side of a house, how many feet above the ground will the top of the ladder be when it rests against the house?

- [A] 8      [B] 9      [C] 11      [D] 12

270. 080020a, P.I. A.A.13

When  $3x^2 - 2x + 1$  is subtracted from  $2x^2 + 7x + 5$ , the result will be

- [A]  $-x^2 + 9x + 4$       [B]  $x^2 - 9x - 4$   
[C]  $x^2 + 5x + 6$       [D]  $-x^2 + 5x + 6$

271. 010528a, P.I. A.A.40

Which point is in the solution set of the system of inequalities shown in the accompanying graph?

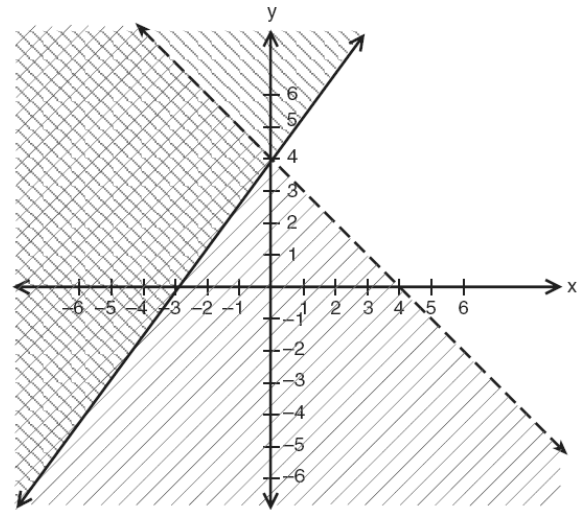

- [A] (-4, 1)      [B] (2, 4)  
[C] (4, -1)      [D] (0, 4)

272. 010433a, P.I. A.A.6

Bob and Latoya both drove to a baseball game at a college stadium. Bob lives 70 miles from the stadium and Latoya lives 60 miles from it, as shown in the accompanying diagram. Bob drove at a rate of 50 miles per hour, and Latoya drove at a rate of 40 miles per hour. If they both left home at the same time, who got to the stadium first?

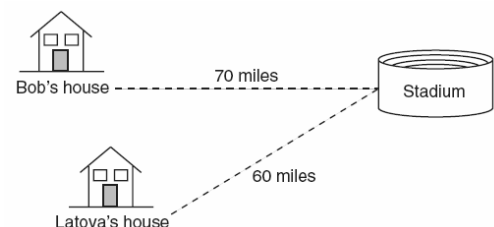

273. 010023a, P.I. A.A.45

A wall is supported by a brace 10 feet long, as shown in the diagram below. If one end of the brace is placed 6 feet from the base of the wall, how many feet up the wall does the brace reach?

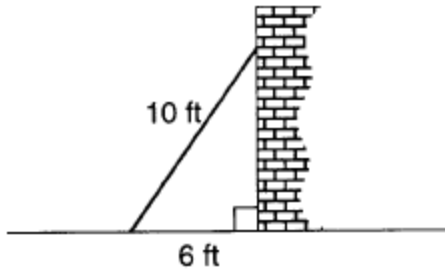

274. 010004a, P.I. A.A.20

Which expression is a factor of  $x^2 + 2x - 15$

- [A]  $(x + 15)$       [B]  $(x - 5)$   
[C]  $(x - 3)$       [D]  $(x + 3)$

275. 010826a, P.I. A.N.3

The expression  $\sqrt{28} - \sqrt{7}$  is equivalent to

- [A] 2    [B] 4    [C]  $3\sqrt{7}$     [D]  $\sqrt{7}$

276. 060033a, P.I. A.S.5

The scores on a mathematics test were 70, 55, 61, 80, 85, 72, 65, 40, 74, 68, and 84.

Complete the accompanying table, and use the table to construct a frequency histogram for these scores.

Score	Tally	Frequency
40–49		
50–59		
60–69		
70–79		
80–89		

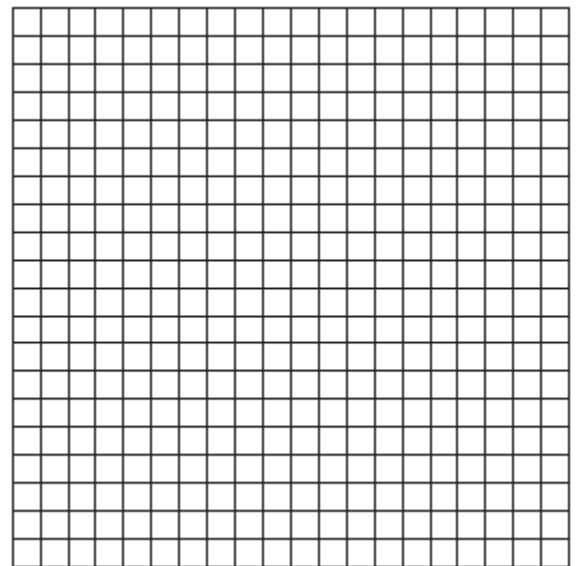

277. 080019a, P.I. A.A.6

A girl can ski down a hill five times as fast as she can climb up the same hill. If she can climb up the hill and ski down in a total of 9 minutes, how many minutes does it take her to climb up the hill?

- [A] 7.5    [B] 1.8    [C] 4.5    [D] 7.2

278. 080126a, P.I. A.2.S.11  
Megan decides to go out to eat. The menu at the restaurant has four appetizers, three soups, seven entrees, and five desserts. If Megan decides to order an appetizer or a soup, and one entree, and two different desserts, how many different choices can she make?
279. 060503a, P.I. A.N.1  
Which equation illustrates the distributive property?  
[A]  $a + 0 = a$                       [B]  $a + b = b + a$   
[C]  $a + (b + c) = (a + b) + c$   
[D]  $5(a + b) = 5a + 5b$
280. 010731a, P.I. A.S.19  
Kimberly has three pair of pants: one black, one red, and one tan. She also has four shirts: one pink, one white, one yellow, and one green. Draw a tree diagram or list the sample space showing all possible outfits that she could wear, if an outfit consists of one pair of pants and one shirt. How many different outfits can Kimberly wear?
281. 060032a, P.I. G.G.22  
A treasure map shows a treasure hidden in a park near a tree and a statue. The map indicates that the tree and the statue are 10 feet apart. The treasure is buried 7 feet from the base of the tree and also 5 feet from the base of the statue. How many places are possible locations for the treasure to be buried? Draw a diagram of the treasure map, and indicate with an **X** *each* possible location of the treasure.
282. 010726a, P.I. A.A.6  
Mario paid \$44.25 in taxi fare from the hotel to the airport. The cab charged \$2.25 for the first mile plus \$3.50 for each additional mile. How many miles was it from the hotel to the airport?  
[A] 13      [B] 11      [C] 10      [D] 12
283. 060417a  
Which phrase does *not* describe a triangle?  
[A] equilateral equiangular  
[B] isosceles right  
[C] acute scalene              [D] obtuse right
284. 010331a, P.I. A.A.26  
At the Phoenix Surfboard Company, \$306,000 in profits was made last year. This profit was shared by the four partners in the ratio 3:3:5:7. How much *more* money did the partner with the largest share make than one of the partners with the smallest share?
285. 060207a, P.I. A.N.4  
If  $3.85 \times 10^6$  is divided by  $385 \times 10^4$ , the result is  
[A]  $3.85 \times 10^{10}$                       [B] 1  
[C] 0.01                                  [D]  $3.85 \times 10^4$
286. 010516a, P.I. A.N.1  
What is the multiplicative inverse of  $\frac{3}{4}$ ?  
[A]  $-\frac{4}{3}$       [B]  $-\frac{3}{4}$       [C] -1      [D]  $\frac{4}{3}$
287. 060107a, P.I. G.G.30  
In isosceles triangle *DOG*, the measure of the vertex angle is three times the measure of one of the base angles. Which statement about  $\triangle DOG$  is true?  
[A]  $\triangle DOG$  is a scalene triangle.  
[B]  $\triangle DOG$  is an obtuse triangle.  
[C]  $\triangle DOG$  is an acute triangle.  
[D]  $\triangle DOG$  is a right triangle.
288. 060023a, P.I. A.N.8  
All seven-digit telephone numbers in a town begin with 245. How many telephone numbers may be assigned in the town if the last four digits do *not* begin or end in a zero?

289. 010519a, P.I. A.RP.11  
In Ms. Wright's English class, 16 students are in band, 7 students play sports, 3 students participate in both activities, and 9 students are not in band and do not play sports. How many students are in Ms. Wright's English class?  
[A] 10 [B] 26 [C] 29 [D] 7
290. 080522a, P.I. A2.A.8  
What is the value of  $2^{-3}$ ?  
[A]  $\frac{1}{6}$  [B]  $\frac{1}{8}$  [C] -6 [D] -8
291. 080612a, P.I. 7.N.11  
What is the first step in simplifying the expression  $(2 - 3 \times 4 + 5)^2$ ?  
[A] subtract 3 from 2 [B] add 4 and 5  
[C] square 5 [D] multiply 3 by 4
292. 010209a, P.I. A.S.20  
A fair coin is tossed three times. What is the probability that the coin will land tails up on the second toss?  
[A]  $\frac{1}{3}$  [B]  $\frac{2}{3}$  [C]  $\frac{1}{2}$  [D]  $\frac{3}{4}$
293. 080409a, P.I. G.G.61  
What are the coordinates of  $P'$ , the image of  $P(-4, 0)$  under the translation  $(x - 3, y + 6)$ ?  
[A] (7,-6) [B] (2,-3)  
[C] (-7,6) [D] (1,6)
294. 010622a, P.I. A.N.3  
The expression  $\frac{6\sqrt{20}}{3\sqrt{5}}$  is equivalent to  
[A]  $2\sqrt{15}$  [B] 8 [C] 4 [D]  $3\sqrt{15}$
295. 080432a, P.I. 7.N.2  
Given:  $\frac{\sqrt{99}}{11}$ ,  $\sqrt{164}$ ,  $\sqrt{196}$   
Identify the expression that is a rational number and explain why it is rational.
296. 010009a, P.I. A.N.5  
Twenty-five percent of 88 is the same as what percent of 22?  
[A]  $12\frac{1}{2}\%$  [B] 100%  
[C] 40% [D] 50%
297. 010220a, P.I. G.G.26  
Which statement is logically equivalent to "If the team has a good pitcher, then the team has a good season"?  
[A] The team has a good pitcher and the team does not have a good season.  
[B] If the team does not have a good season, then the team does not have a good pitcher.  
[C] If the team has a good season, then the team has a good pitcher.  
[D] If the team does not have a good pitcher, then the team does not have a good season.
298. 080416a, P.I. G.G.26  
What is the inverse of the statement "If I do not buy a ticket, then I do not go to the concert"?  
[A] If I do not go to the concert, then I do not buy a ticket.  
[B] If I buy a ticket, then I go to the concert.  
[C] If I go to the concert, then I buy a ticket.  
[D] If I buy a ticket, then I do not go to the concert.

299. 010225a  
Construct a triangle with sides of lengths  $a$ ,  $b$ , and  $c$ , as shown below. Be sure the longest side of your triangle lies on  $\overline{PQ}$  and that point  $P$  is one of the triangle's vertices. [Show all arcs necessary for a valid construction.]

a \_\_\_\_\_  
b \_\_\_\_\_  
c \_\_\_\_\_



300. 060527a, P.I. A.G.1  
The length of a side of a square window in Jessica's bedroom is represented by  $2x - 1$ . Which expression represents the area of the window?
- [A]  $4x^2 + 4x - 1$       [B]  $4x^2 - 4x + 1$   
[C]  $4x^2 + 1$       [D]  $2x^2 + 1$
301. 080214a, P.I. G.G.33  
If the lengths of two sides of a triangle are 4 and 10, what could be the length of the third side?
- [A] 16      [B] 6      [C] 8      [D] 14
302. 010428a, P.I. A.N.1  
Which equation illustrates the associative property of addition?
- [A]  $x + y = y + x$       [B]  $3 + x = 0$   
[C]  $(3 + x) + y = 3 + (x + y)$   
[D]  $3(x + 2) = 3x + 6$
303. 010704a, P.I. G.G.45  
The base of an isosceles triangle is 5 and its perimeter is 11. The base of a similar isosceles triangle is 10. What is the perimeter of the larger triangle?
- [A] 21      [B] 110      [C] 22      [D] 15

304. 060304a  
Which shape does *not* have rotational symmetry?
- [A] regular pentagon      [B] square  
[C] circle      [D] trapezoid
305. 080729a, P.I. G.G.45  
Which is *not* a property of all similar triangles?
- [A] The corresponding angles are congruent.  
[B] The corresponding sides are congruent.  
[C] The altitudes are in the same ratio as the corresponding sides.  
[D] The perimeters are in the same ratio as the corresponding sides.
306. 060501a, P.I. A.N.7  
Jeremy's bedroom has two doors leading into the hallway. His house has four doors leading to the outside. Using the doorways, in how many different ways can Jeremy leave his room and go outside?
- [A] 4      [B] 6      [C] 5      [D] 8
307. 089926a, P.I. A.A.27  
Solve for  $x$ :  $x^2 + 3x - 40 = 0$
308. 080610a, P.I. A.A.15  
For which value of  $x$  is the expression  $\frac{3}{x-2}$  undefined?
- [A] -2      [B] 2      [C] 0      [D] 3
309. 060222a, P.I. A.N.5  
Ninety percent of the ninth grade students at Richbartville High School take algebra. If 180 ninth grade students take algebra, how many ninth grade students do *not* take algebra?





318. 060736a, P.I. G.G.38

In the accompanying diagram of parallelogram  $ABCD$ ,  $m\angle B = 5x$  and  $m\angle C = 2x + 12$ . Find the number of degrees in  $\angle D$ .

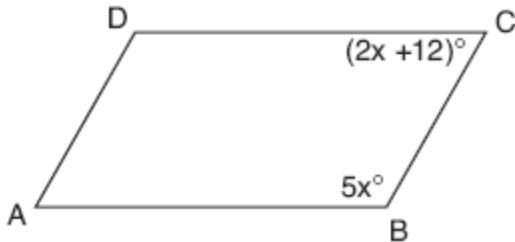

319. 010232a, P.I. A.A.7

When Tony received his weekly allowance, he decided to purchase candy bars for all his friends. Tony bought three Milk Chocolate bars and four Creamy Nougat bars, which cost a total of \$4.25 without tax. Then he realized this candy would not be enough for all his friends, so he returned to the store and bought an additional six Milk Chocolate bars and four Creamy Nougat bars, which cost a total of \$6.50 without tax. How much did *each* type of candy bar cost?

320. 060328a, P.I. A.N.5

In a town election, candidates  $A$  and  $B$  were running for mayor. There were 30,500 people

eligible to vote, and  $\frac{3}{4}$  of them actually

voted. Candidate  $B$  received  $\frac{1}{3}$  of the votes cast. How many people voted for candidate  $B$ ? What percent of the votes cast, to the *nearest tenth of a percent*, did candidate  $A$  receive?

321. 060618a

If a line is horizontal, its slope is

- [A] 1                      [B] 0  
[C] undefined          [D] negative

322. 010314a, P.I. A.N.1

Which equation illustrates the multiplicative identity element?

- [A]  $x \cdot \frac{1}{x} = 1$                       [B]  $x \cdot 1 = x$   
[C]  $x - x = 0$                       [D]  $x + 0 = x$

323. 060310a, P.I. A.A.22

If  $x + y = 9x + y$ , then  $x$  is equal to

- [A]  $\frac{1}{5}y$     [B]  $y$     [C] 8    [D] 0

324. 060017a, P.I. A.A.6

For five algebra examinations, Maria has an average of 88. What must she score on the sixth test to bring her average up to exactly 90?

- [A] 92    [B] 94    [C] 100    [D] 98

325. 080206a

If the area of a square garden is 48 square feet, what is the length, in feet, of one side of the garden?

- [A]  $4\sqrt{3}$                       [B]  $4\sqrt{6}$   
[C]  $16\sqrt{3}$                       [D]  $12\sqrt{2}$

326. 060707a, P.I. A.A.12

The expression  $\frac{-32x^8}{4x^2}$ ,  $x \neq 0$ , is equivalent to

- [A]  $8x^6$                       [B]  $-8x^6$   
[C]  $-8x^4$                       [D]  $8x^4$

327. 060427a

A box in the shape of a cube has a volume of 64 cubic inches. What is the length of a side of the box?

- [A] 8 in                      [B]  $21\bar{3}$  in  
[C] 16 in                      [D] 4 in

328. 010219a, P.I. 7.N.2

Which is an irrational number?

- [A]  $\frac{3}{4}$  [B]  $\sqrt{9}$  [C]  $\sqrt{3}$  [D] 3.14

329. 060031a, P.I. A.A.7

The owner of a movie theater was counting the money from 1 day's ticket sales. He knew that a total of 150 tickets were sold. Adult tickets cost \$7.50 each and children's tickets cost \$4.75 each. If the total receipts for the day were \$891.25, how many of *each* kind of ticket were sold?

330. 060735a, P.I. A.A.43

Ron and Francine are building a ramp for performing skateboard stunts, as shown in the accompanying diagram. The ramp is 7 feet long and 3 feet high. What is the measure of the angle,  $x$ , that the ramp makes with the ground, to the *nearest tenth of a degree*?

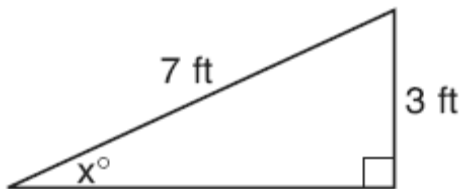

331. 060127a, P.I. A.N.5

A factory packs CD cases into cartons for a music company. Each carton is designed to hold 1,152 CD cases. The Quality Control Unit in the factory expects an error of less than 5% over or under the desired packing number. What is the *least* number and the *most* number of CD cases that could be packed in a carton and still be acceptable to the Quality Control Unit?

332. 010838a, P.I. A.A.44

A lighthouse is built on the edge of a cliff near the ocean, as shown in the accompanying diagram. From a boat located 200 feet from the base of the cliff, the angle of elevation to the top of the cliff is  $18^\circ$  and the angle of elevation to the top of the lighthouse is  $28^\circ$ . What is the height of the lighthouse,  $x$ , to the *nearest tenth of a foot*?

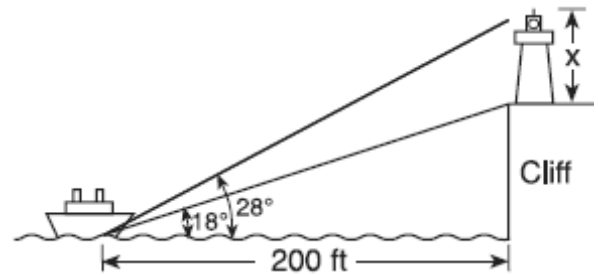

333. 069912a, P.I. G.G.32

In the accompanying diagram of  $\triangle ABC$ ,  $\overline{AB}$  is extended to  $D$ , exterior angle  $CBD$  measures  $145^\circ$ , and  $m\angle C = 75^\circ$ .

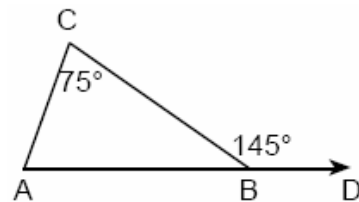

What is  $m\angle CAB$ ?

- [A] 70 [B] 220 [C] 110 [D] 35

334. 080004a, P.I. 7.N.6

Expressed in decimal notation,  $4.726 \times 10^{-3}$  is

- [A] 0.04726 [B] 0.004726  
[C] 4,726 [D] 472.6

335. 010832a, P.I. A.S.20  
As captain of his football team, Jamal gets to call heads or tails for the toss of a fair coin at the beginning of each game. At the last three games, the coin has landed with heads up. What is the probability that the coin will land with heads up at the next game? Explain your answer.

336. 010614a, P.I. G.G.54  
The image of point  $(-2,3)$  under translation  $T$  is  $(3,-1)$ . What is the image of point  $(4,2)$  under the same translation?

- [A]  $(5,4)$                       [B]  $(9,-2)$   
[C]  $(-1,6)$                     [D]  $(0,7)$

337. 060637a, P.I. 6.S.5  
Sara's test scores in mathematics were 64, 80, 88, 78, 60, 92, 84, 76, 86, 78, 72, and 90. Determine the mean, the median, and the mode of Sara's test scores.

338. 060408a, P.I. A.A.1  
Tara buys two items that cost  $d$  dollars each. She gives the cashier \$20. Which expression represents the change she should receive?

- [A]  $20 + 2d$                     [B]  $20 - d$   
[C]  $2d - 20$                     [D]  $20 - 2d$

339. 010707a, P.I. A.A.13  
The expression  $(2x^2 + 6x + 5) - (6x^2 + 3x + 5)$  is equivalent to

- [A]  $-4x^2 + 3x$                 [B]  $4x^2 - 3x$   
[C]  $4x^2 + 3x - 10$         [D]  $-4x^2 - 3x + 10$

340. 010515a, P.I. A2.S.11  
How many different three-member teams can be selected from a group of seven students?

- [A] 5,040    [B] 1    [C] 210    [D] 35

341. 010017a, P.I. A.S.20  
The party registration of the voters in Jonesville is shown in the table below.

Registered Voters in Jonesville	
Party Registration	Number of Voters Registered
Democrat	6,000
Republican	5,300
Independent	3,700

If one of the registered Jonesville voters is selected at random, what is the probability that the person selected is *not* a Democrat?

- [A] 0.333                      [B] 0.400  
[C] 0.600                      [D] 0.667

342. 060235a, P.I. A.G.9  
A rocket is launched from the ground and follows a parabolic path represented by the equation  $y = -x^2 + 10x$ . At the same time, a flare is launched from a height of 10 feet and follows a straight path represented by the equation  $y = -x + 10$ . Using the accompanying set of axes, graph the equations that represent the paths of the rocket and the flare, and find the coordinates of the point or points where the paths intersect.

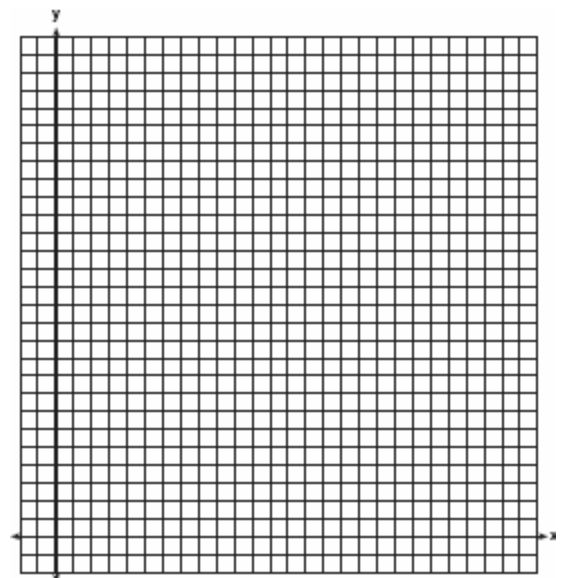

343. 060108a, P.I. A.N.1  
Which equation illustrates the distributive property for real numbers?

[A]  $(1.3 \times 0.07) \times 0.63 = 1.3 \times (0.07 \times 0.63)$

[B]  $\frac{1}{3} + \frac{1}{2} = \frac{1}{2} + \frac{1}{3}$       [C]  $\sqrt{3} + 0 = \sqrt{3}$

[D]  $-3(5 + 7) = (-3)(5) + (-3)(7)$

344. 060208a, P.I. G.G.45  
Two triangles are similar. The lengths of the sides of the smaller triangle are 3, 5, and 6, and the length of the longest side of the larger triangle is 18. What is the perimeter of the larger triangle?

[A] 42      [B] 18      [C] 24      [D] 14

345. 080424a, P.I. 7.N.6  
The number  $156 \times 10^{-2}$  is equivalent to

[A] 0.0156      [B] 0.156

[C] 0.00156      [D] 156

346. 080723a  
When graphed on the coordinate plane, the equations  $y = 2x^2 + 4x + 5$  and  $x^2 + y^2 = 36$  form

[A] a parabola and a circle

[B] two parabolas

[C] a parabola and a straight line

[D] two circles

347. 080115a  
If  $a + b$  is less than  $c + d$ , and  $d + e$  is less than  $a + b$ , then  $e$  is

[A] equal to  $c$       [B] greater than  $d$

[C] less than  $c$       [D] less than  $d$

348. 089925a, P.I. G.G.22  
Maria's backyard has two trees that are 40 feet apart, as shown in the accompanying diagram. She wants to place lampposts so that the posts are 30 feet from both of the trees. Draw a sketch to show where the lampposts could be placed in relation to the trees. How many locations for the lampposts are possible?

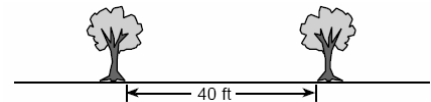

349. 010006a, P.I. A.A.1  
If the number represented by  $n-3$  is an odd integer, which expression represents the next greater odd integer?

[A]  $n - 2$       [B]  $n + 1$       [C]  $n - 1$       [D]  $n - 5$

350. 010110a  
Helen is using a capital H in an art design. The H has

[A] only one line of symmetry

[B] two lines of symmetry and two points of symmetry

[C] only two points of symmetry

[D] two lines of symmetry and only one point of symmetry

351. 080224a, P.I. A.A.6  
A doughnut shop charges \$0.70 for each doughnut and \$0.30 for a carryout box. Shirley has \$5.00 to spend. At most, how many doughnuts can she buy if she also wants them in one carryout box?

352. 089932a, P.I. A.G.1  
If asphalt pavement costs \$0.78 per square foot, determine, to the *nearest cent*, the cost of paving the shaded circular road with center O, an outside radius of 50 feet, and an inner radius of 36 feet, as shown in the accompanying diagram.

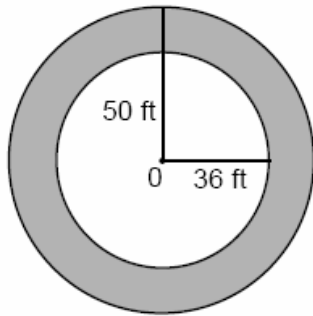

353. 060608a  
What is the length of one side of the square whose perimeter has the same numerical value as its area?  
[A] 3 [B] 4 [C] 5 [D] 6
354. 060214a, P.I. A.A.22  
What is the solution of the equation  $3y - 5y + 10 = 36$ ?  
[A] 13 [B] 4.5 [C] 2 [D] -13
355. 010624a, P.I. 8.G.3  
The ratio of two supplementary angles is 3:6. What is the measure of the *smaller* angle?  
[A]  $10^\circ$  [B]  $60^\circ$  [C]  $20^\circ$  [D]  $30^\circ$
356. 010525a, P.I. A.S.23  
A student council has seven officers, of which five are girls and two are boys. If two officers are chosen at random to attend a meeting with the principal, what is the probability that the first officer chosen is a girl and the second is a boy?  
[A]  $\frac{7}{13}$  [B]  $\frac{10}{42}$  [C]  $\frac{7}{14}$  [D]  $\frac{2}{7}$
357. 010013a, P.I. A.N.8  
How many different 4-letter arrangements can be formed using the letters of the word "JUMP," if each letter is used only once?  
[A] 4 [B] 16 [C] 24 [D] 12
358. 060315a, P.I. A.N.1  
What is the additive inverse of  $\frac{2}{3}$ ?  
[A]  $-\frac{2}{3}$  [B]  $\frac{3}{2}$  [C]  $-\frac{3}{2}$  [D]  $\frac{1}{3}$
359. 060526a, P.I. G.G.39  
Which quadrilateral must have diagonals that are congruent and perpendicular?  
[A] trapezoid [B] rhombus  
[C] parallelogram [D] square
360. 010607a, P.I. A.A.15  
For which value of  $x$  will the fraction  $\frac{3}{2x+4}$  be undefined?  
[A] -2 [B] 2 [C] -4 [D] 0
361. 060110a  
At a school costume party, seven girls wore masks and nine boys did not. If there were 15 boys at the party and 20 students did not wear masks, what was the total number of students at the party?  
[A] 42 [B] 33 [C] 30 [D] 35

362. 010537a

As shown in the accompanying diagram, the length, width, and height of Richard's fish tank are 24 inches, 16 inches, and 18 inches, respectively. Richard is filling his fish tank with water from a hose at the rate of 500 cubic inches per minute. How long will it take, to the *nearest minute*, to fill the tank to a depth of 15 inches?

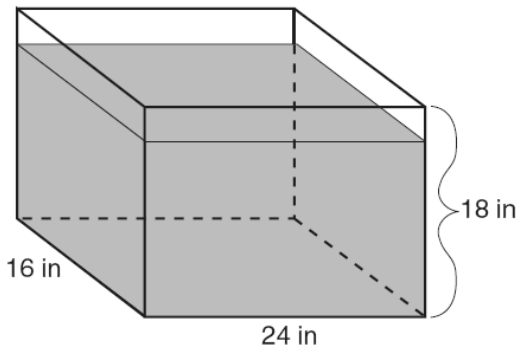

(Not drawn to scale)

363. 010705a, P.I. A.A.22

What is the value of  $n$  in the equation  $3n - 8 = 32 - n$ ?

- [A] -6 [B] 6 [C] 10 [D] -10

364. 060035a, P.I. A.A.8

The area of the rectangular playground enclosure at South School is 500 square meters. The length of the playground is 5 meters longer than the width. Find the dimensions of the playground, in meters. [Only an algebraic solution will be accepted.]

365. 010703a, P.I. 7.N.18

Which point on the accompanying number line best represents the position of  $\sqrt{5}$ ?

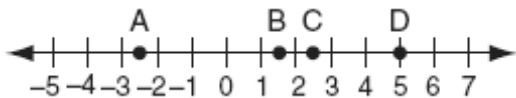

- [A] A [B] C [C] B [D] D

366. 089920a, P.I. A.G.1

What is the perimeter of an equilateral triangle whose height is  $2\sqrt{3}$ ?

- [A]  $12\sqrt{3}$  [B]  $6\sqrt{3}$  [C] 6 [D] 12

367. 060638a, P.I. A.A.7

Sharu has \$2.35 in nickels and dimes. If he has a total of thirty-two coins, how many of *each* coin does he have?

368. 060405a, P.I. G.G.26

Which statement is logically equivalent to "If a triangle is an isosceles triangle, then it has two congruent sides"?

- [A] If a triangle does not have two congruent sides, then it is an isosceles triangle.  
[B] If a triangle is an isosceles triangle, then it does not have two congruent sides.  
[C] If a triangle is not an isosceles triangle, then it has two congruent sides.  
[D] If a triangle does not have two congruent sides, then it is not an isosceles triangle.

369. 060126a, P.I. G.G.38

In the accompanying diagram of parallelogram  $ABCD$ ,  $m\angle A = (2x + 10)$  and  $m\angle B = 3x$ . Find the number of degrees in  $m\angle B$ .

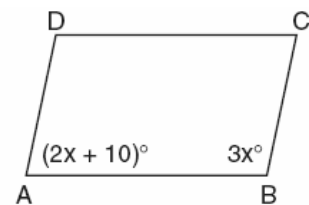

370. 060302a, P.I. A.G.1

The accompanying diagram shows a square with side  $y$  inside a square with side  $x$ .

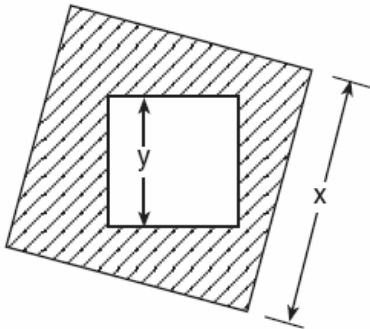

Which expression represents the area of the shaded region?

- [A]  $y^2 - x^2$                       [B]  $x^2$   
[C]  $y^2$                                 [D]  $x^2 - y^2$

371. 060028a, P.I. G.G.16

Tamika has a hard rubber ball whose circumference measures 13 inches. She wants to box it for a gift but can only find cube-shaped boxes of sides 3 inches, 4 inches, 5 inches, or 6 inches. What is the *smallest* box that the ball will fit into with the top on?

372. 010805a, P.I. A.S.20

A box contains 6 dimes, 8 nickels, 12 pennies, and 3 quarters. What is the probability that a coin drawn at random is *not* a dime?

- [A]  $\frac{23}{29}$     [B]  $\frac{8}{29}$     [C]  $\frac{12}{29}$     [D]  $\frac{6}{29}$

373. 010708a, P.I. A.N.5

Which equation represents the direct variation relationship of the equation  $\frac{x}{y} = \frac{1}{2}$ ?

- [A]  $y = 2x$                       [B]  $y = 3x$   
[C]  $x = 2y$                       [D]  $y = x + \frac{1}{2}$

374. 010423a, P.I. A.A.17

What is the sum of  $\frac{2}{x}$  and  $\frac{x}{2}$ ?

- [A]  $\frac{4+x^2}{2x}$                       [B] 1  
[C]  $\frac{4+x}{2x}$                       [D]  $\frac{2+x}{2x}$

375. 010034a, P.I. A2.S.12

Three roses will be selected for a flower vase. The florist has 1 red rose, 1 white rose, 1 yellow rose, 1 orange rose and 1 pink rose from which to choose.

- a* How many different three rose selections can be formed from the 5 roses?  
*b* What is the probability that 3 roses selected at random will contain 1 red rose, 1 white rose, and 1 pink rose?  
*c* What is the probability that 3 roses selected at random will *not* contain an orange rose?

376. 080125a, P.I. A2.A.13

Simplify:  $\sqrt{50r^2s^4}$

377. 010623a, P.I. G.G.22

In the accompanying diagram, point  $P$  lies 3 centimeters from line  $\ell$ .

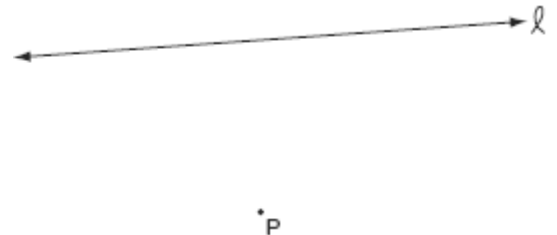

How many points are both 2 centimeters from line  $\ell$  and 1 centimeter from point  $P$ ?

- [A] 4                      [B] 1                      [C] 0                      [D] 2



378. 060610a, P.I. A.S.6

The accompanying box-and-whisker plot represents the scores earned on a science test.

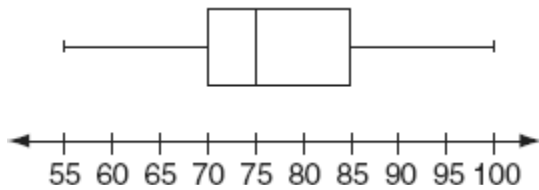

What is the median score?

- [A] 77 [B] 70 [C] 85 [D] 75

379. 010503a, P.I. A.N.7

A deli has five types of meat, two types of cheese, and three types of bread. How many different sandwiches, consisting of one type of meat, one type of cheese, and one type of bread, does the deli serve?

- [A] 10 [B] 30 [C] 25 [D] 75

380. 080035a, P.I. A.A.8

Jack is building a rectangular dog pen that he wishes to enclose. The width of the pen is 2 yards less than the length. If the area of the dog pen is 15 square yards, how many yards of fencing would he need to completely enclose the pen?

381. 010212a, P.I. A.G.1

What is the area of a square whose perimeter is represented by  $12x$ ?

- [A]  $12x^2$  [B]  $6x\sqrt{2}$   
[C]  $9x^2$  [D]  $144x^2$

382. 080231a, P.I. A.A.44

In the accompanying diagram,  $x$  represents the length of a ladder that is leaning against a wall of a building, and  $y$  represents the distance from the foot of the ladder to the base of the wall. The ladder makes a  $60^\circ$  angle with the ground and reaches a point on the wall 17 feet above the ground. Find the number of feet in  $x$  and  $y$ .

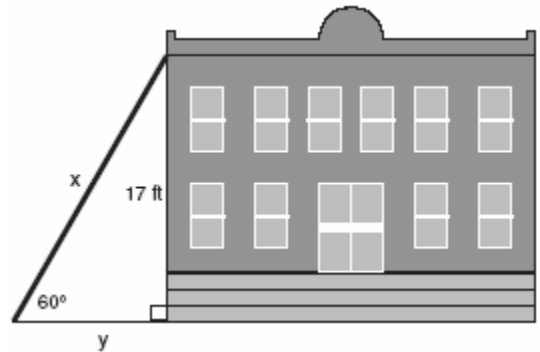

383. 080515a

A line segment on the coordinate plane has endpoints  $(2,4)$  and  $(4,y)$ . The midpoint of the segment is point  $(3,7)$ . What is the value of  $y$ ?

- [A] 5 [B] 10 [C] 11 [D] -2

384. 060231a, P.I. A.A.43, G.G.48

As seen in the accompanying diagram, a person can travel from New York City to Buffalo by going north 170 miles to Albany and then west 280 miles to Buffalo.

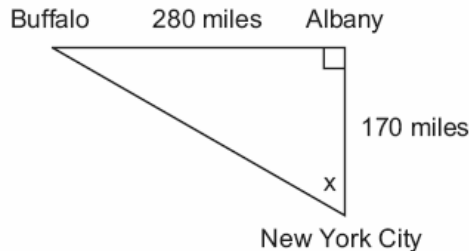

a If an engineer wants to design a highway to connect New York City directly to Buffalo, at what angle,  $x$ , would she need to build the highway? Find the angle to the *nearest degree*.

b To the *nearest mile*, how many miles would be saved by traveling directly from New York City to Buffalo rather than by traveling first to Albany and then to Buffalo?

385. 069905a, P.I. G.G.33

The direct distance between city A and city B is 200 miles. The direct distance between city B and city C is 300 miles. Which could be the direct distance between city C and city A?

- [A] 550 miles                      [B] 50 miles  
[C] 650 miles                      [D] 350 miles

386. 010124a, P.I. G.G.54

The coordinates of the endpoints of  $\overline{AB}$  are  $A(0,2)$  and  $B(4,6)$ . Graph and state the coordinates of  $A'$  and  $B'$ , the images of  $A$  and  $B$  after  $\overline{AB}$  is reflected in the  $x$ -axis.

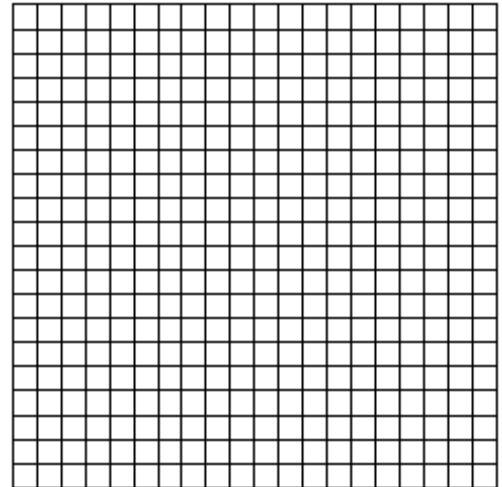

387. 060502a, P.I. 7.A.6

The amount of time,  $t$ , in seconds, it takes an object to fall a distance,  $d$ , in meters, is

expressed by the formula  $t = \sqrt{\frac{d}{4.9}}$ .

Approximately how long will it take an object to fall 75 meters?

- [A] 0.26 sec                      [B] 7.7 sec  
[C] 3.9 sec                        [D] 2.34 sec

388. 060431a, P.I. G.G.32

In the accompanying diagram of  $\triangle BCD$ ,  $m\angle C = 70$ ,  $m\angle CDE = 130$ , and side  $\overline{BD}$  is extended to  $A$  and to  $E$ . Find  $m\angle CBA$ .

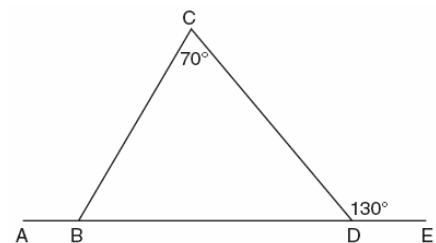

389. 060307a, P.I. G.G.45  
A triangle has sides whose lengths are 5, 12, and 13. A similar triangle could have sides with lengths of

[A] 3, 4, and 15      [B] 6, 8, and 10  
[C] 10, 24, and 26    [D] 7, 24, and 25

390. 060623a, P.I. A.A.20  
Factored completely, the expression  $2y^2 + 12y - 54$  is equivalent to

[A]  $2(y - 3)(y - 9)$       [B]  $(2y + 6)(y - 9)$   
[C]  $(y + 6)(2y - 9)$       [D]  $2(y + 9)(y - 3)$

391. 060333a, P.I. A.G.4  
An architect is designing a museum entranceway in the shape of a parabolic arch represented by the equation  $y = -x^2 + 20x$ , where  $0 \leq x \leq 20$  and all dimensions are expressed in feet. On the accompanying set of axes, sketch a graph of the arch and determine its maximum height, in feet.

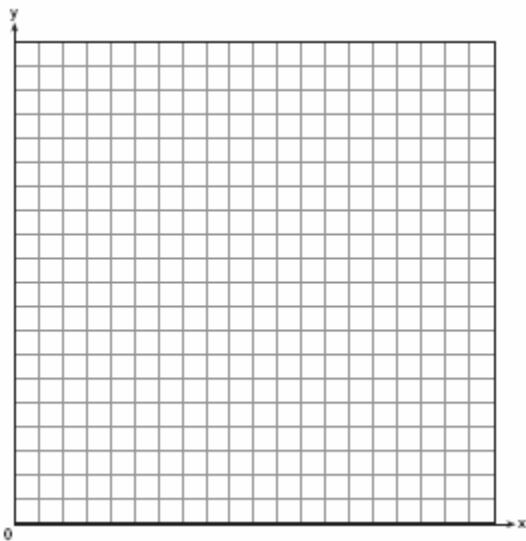

392. 060210a  
If two lines are parallel and the slope of one of the lines is  $m$ , what is the product of their slopes?

[A]  $m^2$     [B] 1    [C] 0    [D]  $2m$

393. 089921a, P.I. A.A.22  
Solve for  $x$ :  $2(x - 3) = 1.2 - x$

394. 069920a, P.I. A.N.3  
The expression  $\sqrt{27} + \sqrt{12}$  is equivalent to

[A]  $13\sqrt{3}$       [B]  $5\sqrt{3}$   
[C]  $5\sqrt{6}$       [D]  $\sqrt{39}$

395. 010520a, P.I. A.A.27  
What is the solution set for the equation  $x^2 - 5x + 6 = 0$ ?

[A]  $\{-2, -3\}$       [B]  $\{6, -1\}$   
[C]  $\{-6, 1\}$       [D]  $\{2, 3\}$

396. 080010a, P.I. A.N.1  
The operation  $*$  for the set  $\{p, r, s, v\}$  is defined in the accompanying table. What is the inverse element of  $r$  under the operation  $*$ ?

$*$	$p$	$r$	$s$	$v$
$p$	$s$	$v$	$p$	$r$
$r$	$v$	$p$	$r$	$s$
$s$	$p$	$r$	$s$	$v$
$v$	$r$	$s$	$v$	$p$

[A]  $p$     [B]  $s$     [C]  $r$     [D]  $v$

397. 080733a, P.I. A.A.27  
What is the positive solution of the equation  $4x^2 - 36 = 0$ ?

398. 080536a, P.I. A.A.44  
A tree casts a shadow that is 20 feet long. The angle of elevation from the end of the shadow to the top of the tree is  $66^\circ$ . Determine the height of the tree, to the nearest foot.

399. 060533a, P.I. A.RP.11  
In a survey of 400 teenage shoppers at a large mall, 240 said they shopped at Abernathy's, 210 said they shopped at Bongo Republic, and 90 said they shopped at both stores. How many of the teenage shoppers surveyed did not shop at either store?

400. 010803a, P.I. G.G.25  
The statement " $a > 2$  and  $a < 5$ " is true when  $a$  is equal to  
[A] 3 [B] 5 [C] 2 [D] 10

401. 060504a, P.I. 7.N.5  
The mass of an orchid seed is approximately 0.0000035 gram. Written in scientific notation, that mass is equivalent to  $3.5 \times 10^n$ . What is the value of  $n$ ?  
[A] -8 [B] -7 [C] -5 [D] -6

402. 010213a, P.I. 7.N.3  
Which inequality is true if  $x = \frac{3.04}{1.48}$ ,  $y = 1.99 + 0.33$ , and  $z = (1.3)^3$ ?  
[A]  $y < z < x$  [B]  $x < z < y$   
[C]  $x < y < z$  [D]  $y < x < z$

403. 010821a, P.I. A.N.1  
The additive inverse of  $\frac{1}{a}$  is  
[A]  $a$  [B]  $-a$  [C] 0 [D]  $-\frac{1}{a}$

404. 080228a, P.I. A.N.5  
There are 28 students in a mathematics class. If  $\frac{1}{4}$  of the students are called to the guidance office,  $\frac{1}{3}$  of the remaining students are called to the nurse, and, finally,  $\frac{1}{2}$  of those left go to the library, how many students remain in the classroom?

405. 069902a, P.I. G.G.25  
The statement "If  $x$  is divisible by 8, then it is divisible by 6" is false if  $x$  equals  
[A] 48 [B] 14 [C] 32 [D] 6

406. 060734a, P.I. G.G.18  
Using a compass and straightedge, construct the perpendicular bisector of  $\overline{AB}$  shown below. Show all construction marks.



407. 060133a, P.I. A.A.7  
Ramón rented a sprayer and a generator. On his first job, he used each piece of equipment for 6 hours at a total cost of \$90. On his second job, he used the sprayer for 4 hours and the generator for 8 hours at a total cost of \$100. What was the hourly cost of *each* piece of equipment?

408. 010317a, P.I. G.G.22  
The locus of points equidistant from two sides of an acute scalene triangle is  
[A] a median [B] an altitude  
[C] an angle bisector [D] the third side

409. 010304a, P.I. 7.N.3  
In which list are the numbers in order from least to greatest?  
[A]  $\sqrt{3}$ ,  $\pi$ , 3.2,  $3\frac{1}{3}$  [B]  $\sqrt{3}$ , 3.2,  $\pi$ ,  $3\frac{1}{3}$   
[C] 3.2,  $\pi$ ,  $3\frac{1}{3}$ ,  $\sqrt{3}$  [D] 3.2,  $3\frac{1}{3}$ ,  $\sqrt{3}$ ,  $\pi$

410. 010702a, P.I. 8.G.5

The accompanying diagram shows two parallel roads, Hope Street and Grand Street, crossed by a transversal road, Broadway.

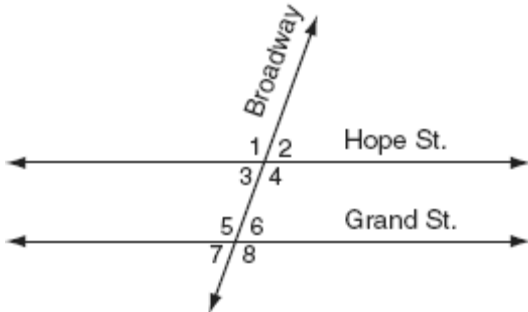

If  $m\angle 1 = 110$ , what is the measure of  $\angle 7$ ?

- [A]  $40^\circ$  [B]  $70^\circ$  [C]  $180^\circ$  [D]  $110^\circ$

411. 080421a, P.I. 8.G.4

The accompanying diagram shows a football player crossing the 20-yard line at an angle of  $30^\circ$  and continuing along the same path.

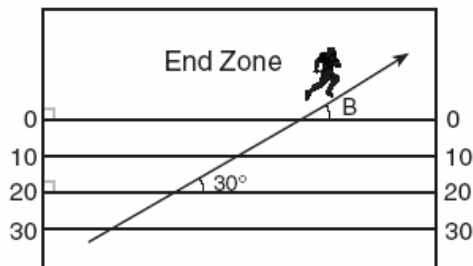

What is the measure of angle B, where the player crosses into the end zone?

- [A]  $180^\circ$  [B]  $30^\circ$  [C]  $150^\circ$  [D]  $60^\circ$

412. 010417a

Triangle  $ABC$  represents a metal flag on pole  $AD$ , as shown in the accompanying diagram. On a windy day the triangle spins around the pole so fast that it looks like a three-dimensional shape.

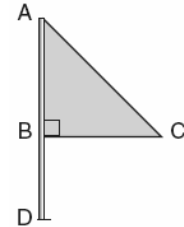

Which shape would the spinning flag create?

- [A] right circular cylinder [B] sphere  
[C] pyramid [D] cone

413. 080221a, P.I. G.G.31

In the accompanying diagram of  $\triangle BCD$ ,  $\triangle ABC$  is an equilateral triangle and  $AD = AB$ . What is the value of  $x$ , in degrees?

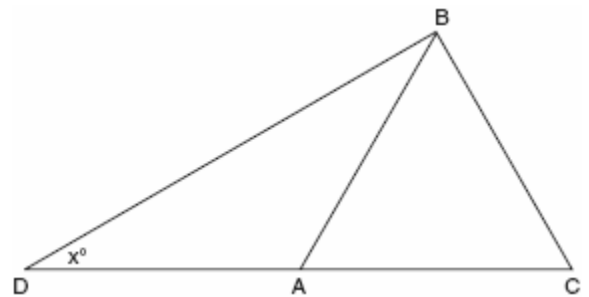

414. 060015a, P.I. A.A.13

The expression  $(x - 6)^2$  is equivalent to

- [A]  $x^2 - 12x + 36$  [B]  $x^2 + 12x + 36$   
[C]  $x^2 - 36$  [D]  $x^2 + 36$

415. 060224a, P.I. A.N.1

An addition table for a subset of real numbers is shown below. Which number is the identity element? Explain your answer.

+	0	1	2	3
0	0	1	2	3
1	1	2	3	4
2	2	3	4	0
3	3	4	0	1

416. 060413a, P.I. A.N.1

Which property of real numbers is illustrated by the equation  $-\sqrt{3} + \sqrt{3} = 0$

- [A] commutative property of addition
- [B] associative property of addition
- [C] additive identity
- [D] additive inverse

417. 080624a, P.I. G.G.66

The coordinates of  $A$  are  $(-9, 2)$  and the coordinates of  $G$  are  $(3, 14)$ . What are the coordinates of the midpoint of  $\overline{AG}$ ?

- [A]  $(-6, 6)$
- [B]  $(-3, 8)$
- [C]  $(-6, 16)$
- [D]  $(-21, -10)$

418. 069915a, P.I. A.A.26

During a recent winter, the ratio of deer to foxes was 7 to 3 in one county of New York State. If there were 210 foxes in the county, what was the number of deer in the county?

- [A] 280
- [B] 490
- [C] 147
- [D] 90

419. 060622a, P.I. G.G.25

If  $x = 3$ , which statement is *false*?

- [A]  $x$  is odd and  $2x$  is even.
- [B]  $x$  is prime and  $x$  is odd.
- [C]  $x$  is not prime and  $x$  is odd.
- [D]  $x$  is odd or  $x$  is even.

420. 010115a, P.I. 8.G.13

What is the slope of line  $\ell$  in the accompanying diagram?

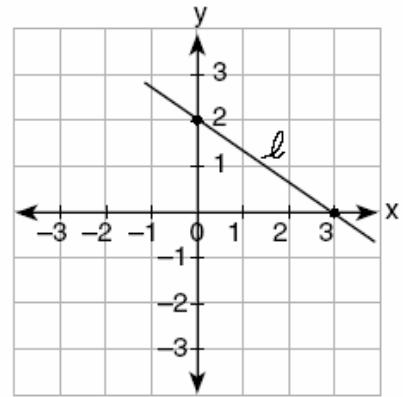

- [A]  $-\frac{2}{3}$
- [B]  $-\frac{3}{2}$
- [C]  $\frac{2}{3}$
- [D]  $\frac{3}{2}$

421. 060507a

The accompanying diagram shows the graphs of a linear equation and a quadratic equation.

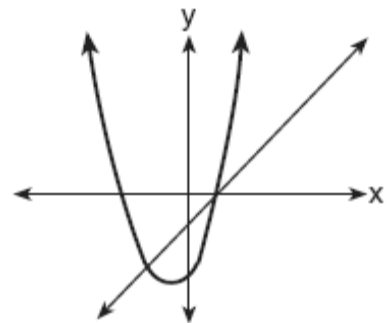

How many solutions are there to this system of equations?

- [A] 3
- [B] 2
- [C] 0
- [D] 1

422. 010430a, P.I. A.A.13

The expression  $(a^2 + b^2)^2$  is equivalent to

- [A]  $a^4 + a^2b^2 + b^4$
- [B]  $a^4 + 2a^2b^2 + b^4$
- [C]  $a^4 + 4a^2b^2 + b^4$
- [D]  $a^4 + b^4$

423. 080407a, P.I. 8.G.1  
 $\overline{AB}$  and  $\overline{CD}$  intersect at point  $E$ ,  
 $m\angle AEC = 6x + 20$ , and  $m\angle DEB = 10x$ .  
 What is the value of  $x$ ?

[A]  $21\frac{1}{4}$  [B] 5 [C] 10 [D]  $4\frac{3}{8}$

424. 089914a, P.I. A.A.6  
 In a hockey league, 87 players play on seven different teams. Each team has at least 12 players. What is the largest possible number of players on any one team?

[A] 21 [B] 13 [C] 15 [D] 14

425. 010835a, P.I. G.G.38  
 As shown in the accompanying diagram, a rectangular gate has two diagonal supports. If  $m\angle 1 = 42$ , what is  $m\angle 2$ ?

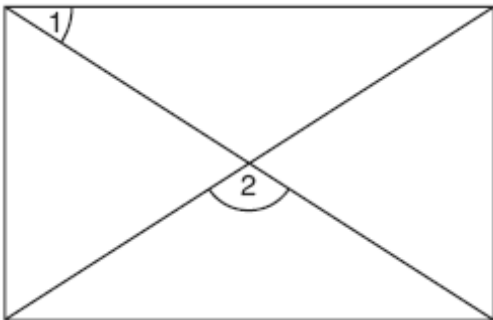

426. 010437a, P.I. A.G.1  
 A wheel has a radius of 5 feet. What is the minimum number of *complete* revolutions that the wheel must make to roll at least 1,000 feet?

427. 080738a, P.I. A.G.1  
 The accompanying diagram represents a scale drawing of the property where Brendan's business is located. He needs to purchase rock salt to melt the ice on the parking lot (shaded area) around his building. A bag of rock salt covers an area of 1,500 square feet. How many bags of rock salt does Brendan need to purchase to salt the entire parking lot?

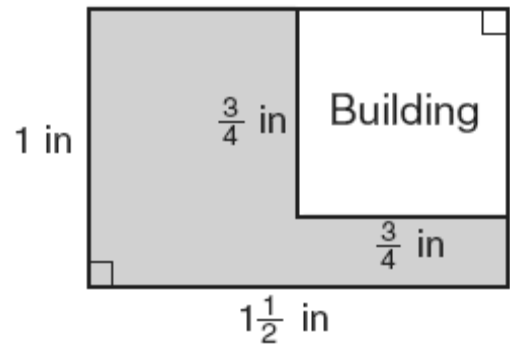

Scale:  $\frac{1}{4}$  in = 18 ft

428. 060026a, P.I. A.RP.11  
 The accompanying Venn diagram shows the number of students who take various courses. All students in circle A take mathematics. All in circle B take science. All in circle C take technology. What percentage of the students take mathematics or technology?

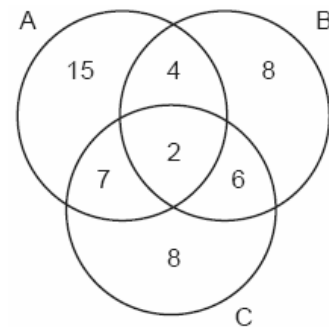

429. 060131a, P.I. A.A.8  
 Find three consecutive odd integers such that the product of the first and the second exceeds the third by 8.

430. 010228a, P.I. A.A.7  
A total of 600 tickets were sold for a concert. Twice as many tickets were sold in advance than were sold at the door. If the tickets sold in advance cost \$25 each and the tickets sold at the door cost \$32 each, how much money was collected for the concert?
431. 080527a, P.I. A2.S.11  
The expression  ${}_9C_2$  is equivalent to  
[A]  ${}_9P_2$  [B]  ${}_9C_7$  [C]  ${}_9P_7$  [D]  $\frac{9!}{2!}$
432. 080636a, P.I. A.N.7  
Debbie goes to a diner famous for its express lunch menu. The menu has five appetizers, three soups, seven entrees, six vegetables, and four desserts. How many different meals consisting of either an appetizer *or* a soup, one entree, one vegetable, and one dessert can Debbie order?
433. 060412a  
What is the least common denominator of  $\frac{1}{2}$ ,  $\frac{2}{7x}$ , and  $\frac{5}{x}$ ?  
[A]  $14x^2$  [B]  $9x$  [C]  $14x$  [D]  $2x$
434. 060708a, P.I. A.A.13  
What is the product of  $(c+8)$  and  $(c-5)$ ?  
[A]  $c^2 - 3c - 40$  [B]  $c^2 - 40$   
[C]  $c^2 + 3c - 40$  [D]  $c^2 + 13c - 40$
435. 080605a, P.I. A.A.12  
What is the product of  $10x^4y^2$  and  $3xy^3$ ?  
[A]  $30x^4y^6$  [B]  $30x^5y^6$   
[C]  $30x^5y^5$  [D]  $30x^4y^5$
436. 080135a, P.I. A.A.11  
Solve the following system of equations algebraically:  
$$y = x^2 + 4x - 2$$
$$y = 2x + 1$$
437. 010012a  
If the circumference of a circle is  $10\pi$  inches, what is the area, in square inches, of the circle?  
[A]  $10\pi$  [B]  $25\pi$   
[C]  $50\pi$  [D]  $100\pi$



438. 080721a, P.I. G.G.61

The accompanying diagram shows the starting position of the spinner on a board game.



How does this spinner appear after a  $270^\circ$  counterclockwise rotation about point  $P$ ?

[A]

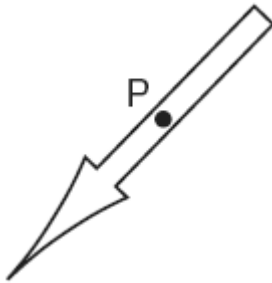

[B]



[C]



[D]

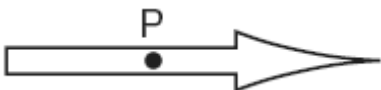

439. 080412a, P.I. A.A.7

The ratio of Tariq's telephone bill to Pria's telephone bill was 7:5. Tariq's bill was \$14 more than Pria's bill. What was Tariq's bill?

- [A] \$28 [B] \$21 [C] \$49 [D] \$35

440. 010606b, P.I. A.G.10

Which is an equation of the line of symmetry for the parabola in the accompanying diagram?

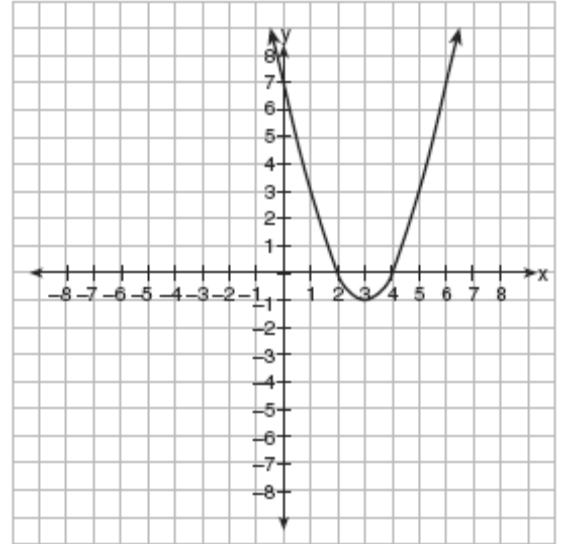

[A]  $x = 2$

[B]  $y = 3$

[C]  $x = 3$

[D]  $x = 4$

441. 080534a, P.I. 7.S.6

Nine hundred students were asked whether they thought their school should have a dress code. A circle graph was constructed to show the results. The central angles for two of the three sectors are shown in the accompanying diagram. What is the number of students who felt that the school should have no dress code?

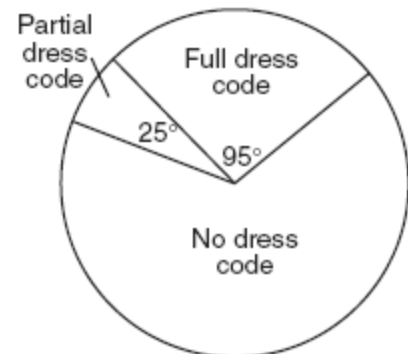

442. 010434a, P.I. A.RP.11  
A car dealer has 22 vehicles on his lot. If 8 of the vehicles are vans and 6 of the vehicles are red, and 10 vehicles are neither vans nor red, how many red vans does he have on his lot?

443. 010629a, P.I. A.G.6  
Which inequality is represented by the accompanying graph?

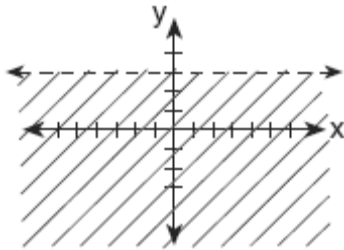

- [A]  $y \leq 3$                       [B]  $y > 3$   
[C]  $y \geq 3$                       [D]  $y < 3$

444. 060025a  
The accompanying graph represents the yearly cost of playing 0 to 5 games of golf at the Shadybrook Golf Course. What is the total cost of joining the club and playing 10 games during the year?

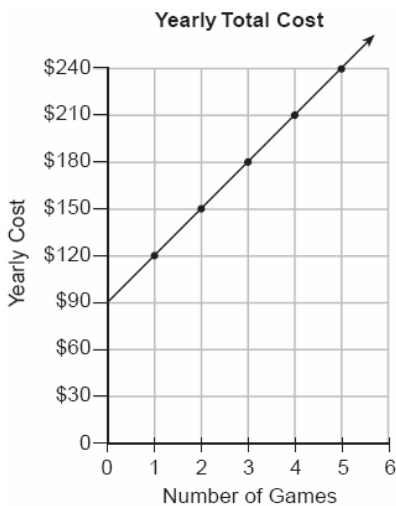

445. 080017a, P.I. A.G.4  
Which is an equation of the parabola shown in the accompanying diagram?

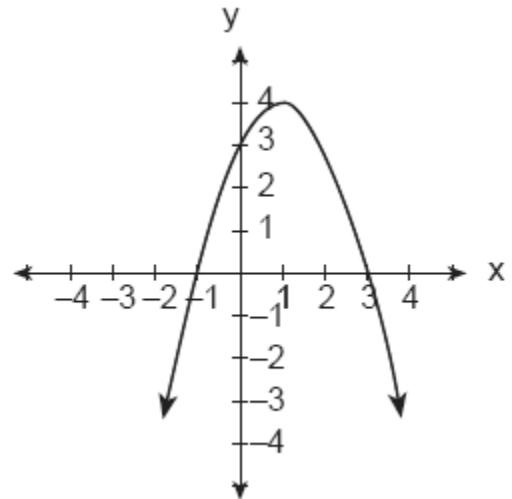

- [A]  $y = x^2 - 2x + 3$             [B]  $y = -x^2 + 2x + 3$   
[C]  $y = -x^2 - 2x + 3$             [D]  $y = x^2 + 2x + 3$

446. 010108a, P.I. A.A.13  
The sum of  $3x^2 + 4x - 2$  and  $x^2 - 5x + 3$  is
- [A]  $4x^2 - x - 1$             [B]  $4x^2 + x + 1$   
[C]  $4x^2 - x + 1$             [D]  $4x^2 + x - 1$

447. 010830a, P.I. G.G.22  
The locus of points equidistant from the points (4,-5) and (4,7) is the line whose equation is
- [A]  $y = 2$                       [B]  $x = 4$   
[C]  $y = 1$                       [D]  $x = 1$

448. 080402a, P.I. 6.S.5  
Rosario and Enrique are in the same mathematics class. On the first five tests, Rosario received scores of 78, 77, 64, 86, and 70. Enrique received scores of 90, 61, 79, 73, and 87. How much higher was Enrique's average than Rosario's average?
- [A] 15 points                      [B] 4 points  
[C] 3 points                        [D] 2 points

449. 010511a, P.I. A2.A.9

Which expression is equivalent to  $x^{-4}$ ?

- [A]  $-4x$  [B]  $0$  [C]  $\frac{1}{x^4}$  [D]  $x^4$

450. 010738a, P.I. A.G.7

Graph the following systems of inequalities on the accompanying set of axes and label the solution set  $S$ :

$$y > x - 4$$

$$y + x \geq 2$$

[Only a graphic solution can receive full credit.]

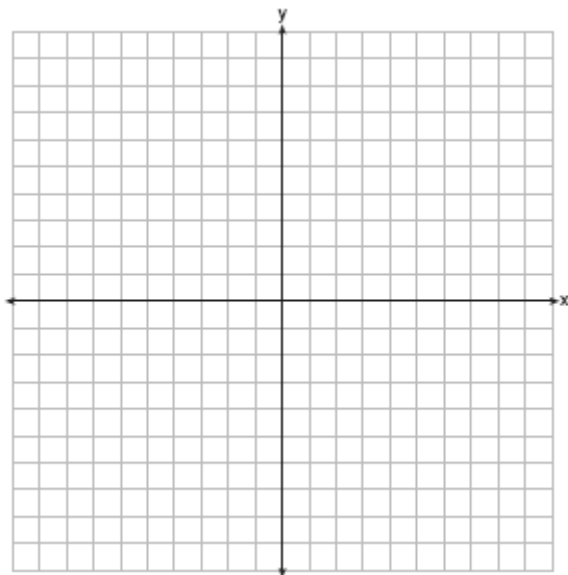

451. 010416a, P.I. 7.N.2

Which number is irrational?

- [A]  $0.3333$  [B]  $\sqrt{9}$  [C]  $\frac{2}{3}$  [D]  $\sqrt{8}$

452. 060418a, P.I. A.A.6

The number of people on the school board is represented by  $x$ . Two subcommittees with an equal number of members are formed, one with  $\frac{2}{3}x - 5$  members and the other with  $\frac{x}{4}$  members. How many people are on the school board?

- [A]  $12$  [B]  $8$  [C]  $4$  [D]  $20$

453. 060718a, P.I. G.G.37

One piece of the birdhouse that Natalie is building is shaped like a regular pentagon, as shown in the accompanying diagram.

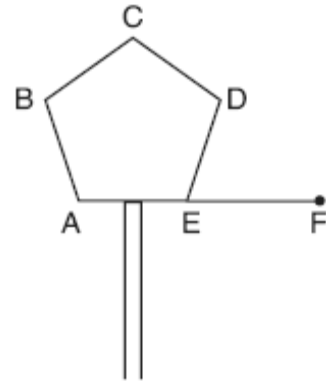

If side  $AE$  is extended to point  $F$ , what is the measure of exterior angle  $DEF$ ?

- [A]  $72^\circ$  [B]  $36^\circ$  [C]  $108^\circ$  [D]  $144^\circ$

454. 010406a, P.I. 8.N.2

What is the value of  $\frac{x^2 - 4y}{2}$ , if  $x = 4$  and  $y = -3$ ?

- [A]  $10$  [B]  $2$  [C]  $-2$  [D]  $14$

455. 010813a, P.I. 7.A.10

Which equation expresses the relationship between  $x$  and  $y$ , as shown in the accompanying table?

$x$	0	1	2	3	4
$y$	2	5	8	11	14

- [A]  $y = 2x + 3$  [B]  $y = x + 3$   
[C]  $y = x + 2$  [D]  $y = 3x + 2$

456. 010107a, P.I. A.N.1

If  $a$  and  $b$  are integers, which equation is always true?

- [A]  $a + b = b + a$  [B]  $a + 2b = b + 2a$   
[C]  $a - b = b - a$  [D]  $\frac{a}{b} = \frac{b}{a}$

457. 060435a, P.I. G.G.18

Using only a compass and a straightedge, construct the perpendicular bisector of  $\overline{AB}$  and label it  $c$ . [Leave all construction marks.]



458. 080401a

Which diagram shows a dotted line that is *not* a line of symmetry?

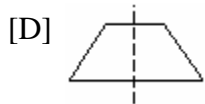
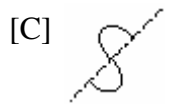
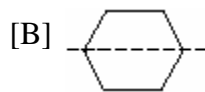
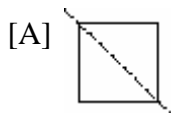

459. 010132a, P.I. A.S.5

On a science quiz, 20 students received the following scores: 100, 95, 95, 90, 85, 85, 85, 80, 80, 80, 80, 75, 75, 75, 70, 70, 65, 65, 60, 55. Construct a statistical graph, such as a histogram or a stem-and-leaf plot, to display this data. [Be sure to title the graph and label all axes or parts used.]

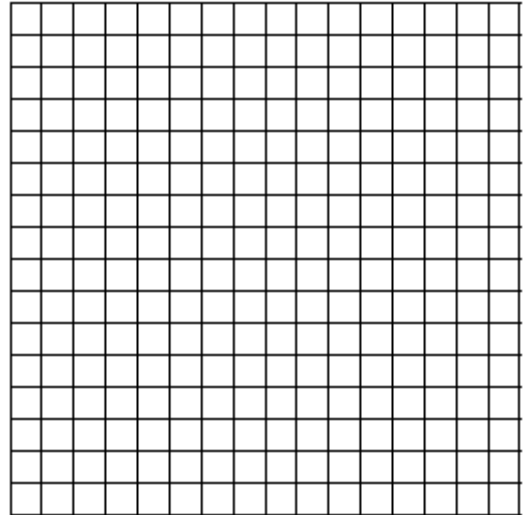

460. 060121a, P.I. A.RP.11

A school district offers hockey and basketball. The result of a survey of 300 students showed:  
120 students play hockey, only  
90 students play basketball, only  
30 students do not participate in either sport  
Of those surveyed, how many students play both hockey and basketball?

461. 089901a

A roll of candy is shown in the accompanying diagram.



The shape of the candy is best described as a

- [A] rectangular solid    [B] cylinder  
[C] cone    [D] pyramid

462. 010018a, P.I. A.N.4  
If the number of molecules in 1 mole of a substance is  $6.02 \times 10^{23}$ , then the number of molecules in 100 moles is

[A]  $6.02 \times 10^{24}$       [B]  $6.02 \times 10^{25}$   
[C]  $6.02 \times 10^{22}$       [D]  $6.02 \times 10^{21}$

463. 010616a, P.I. G.G.26  
Which statement is the inverse of "If the waves are small, I do not go surfing"?

[A] If I go surfing, the waves are not small.  
[B] If the waves are not small, I do not go surfing.  
[C] If I do not go surfing, the waves are small.  
[D] If the waves are not small, I go surfing.

464. 010601a, P.I. A.A.22  
What is the value of  $x$  in the equation  $5(2x - 7) = 15x - 10$ ?

[A] 1      [B] 0.6      [C] -9      [D] -5

465. 080021a, P.I. G.G.45  
The accompanying diagram shows a section of the city of Tacoma. High Road, State Street, and Main Street are parallel and 5 miles apart. Ridge Road is perpendicular to the three parallel streets. The distance between the intersection of Ridge Road and State Street and where the railroad tracks cross State Street is 12 miles. What is the distance between the intersection of Ridge Road and Main Street and where the railroad tracks cross Main Street?

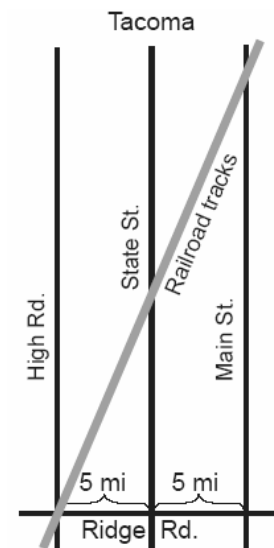

466. 060202a, P.I. A.S.20  
If the probability that it will rain on Thursday is  $\frac{5}{6}$ , what is the probability that it will *not* rain on Thursday?

[A]  $\frac{1}{6}$       [B] 1      [C] 0      [D]  $\frac{5}{6}$

467. 060130a, P.I. A.S.23  
Mr. Yee has 10 boys and 15 girls in his mathematics class. If he chooses two students at random to work on the blackboard, what is the probability that both students chosen are girls?

468. 010305a, P.I. G.G.56

The accompanying diagram shows a transformation.

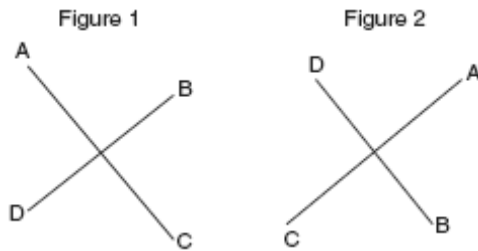

Which transformation performed on figure 1 resulted in figure 2?

- [A] dilation                      [B] rotation  
[C] reflection                    [D] translation

469. 080013a, P.I. A.A.10

What is the value of  $y$  in the following system of equations?

$$\begin{aligned} 2x + 3y &= 6 \\ 2x + y &= -2 \end{aligned}$$

- [A] -3      [B] 4      [C] 1      [D] 2

470. 089919a, P.I. A.A.37

What is the slope of the line whose equation is  $3x - 4y - 16 = 0$ ?

- [A] 3      [B] -4      [C]  $\frac{3}{4}$       [D]  $\frac{4}{3}$

471. 010117a, P.I. A.A.26

In a molecule of water, there are two atoms of hydrogen and one atom of oxygen. How many atoms of hydrogen are in 28 molecules of water?

- [A] 14      [B] 42      [C] 29      [D] 56

472. 060606a, P.I. G.G.36

In the accompanying diagram,  $\overleftrightarrow{AB} \parallel \overleftrightarrow{CD}$ . From point  $E$  on  $\overleftrightarrow{AB}$ , transversals  $\overleftrightarrow{EF}$  and  $\overleftrightarrow{EG}$  are drawn, intersecting  $\overleftrightarrow{CD}$  at  $H$  and  $I$ , respectively.

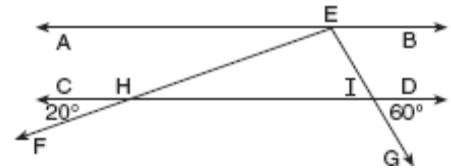

If  $m\angle CHF = 20$  and  $m\angle DIG = 60$ , what is  $m\angle HEI$ ?

- [A] 80      [B] 60      [C] 120      [D] 100

473. 010120a, P.I. 7.N.3

Let  $x$  and  $y$  be numbers such that  $0 < x < y < 1$ , and let  $d = x - y$ . Which graph could represent the location of  $d$  on the number line?

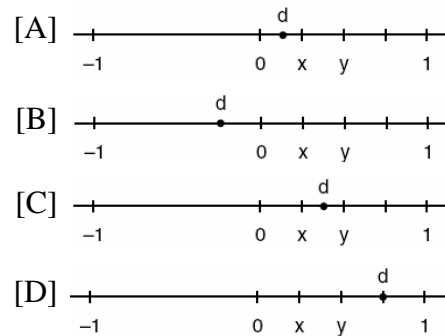

474. 080607a, P.I. 7.N.5

A micron is a unit used to measure specimens viewed with a microscope. One micron is equivalent to 0.00003937 inch. How is this number expressed in scientific notation?

- [A]  $3937 \times 10^8$                       [B]  $3.937 \times 10^5$   
[C]  $3.937 \times 10^{-5}$                     [D]  $3937 \times 10^{-8}$

475. 010628a, P.I. A2.S.9  
A committee of five members is to be randomly selected from a group of nine freshmen and seven sophomores. Which expression represents the number of different committees of three freshmen and two sophomores that can be chosen?

[A]  ${}_9C_3 + {}_7C_2$       [B]  ${}_9C_3 \cdot {}_7C_2$   
[C]  ${}_9P_3 \cdot {}_7P_2$       [D]  ${}_{16}C_3 \cdot {}_{16}C_2$

476. 080107a, P.I. A.N.6  
The value of  $5!$  is

[A] 5      [B]  $\frac{1}{5}$       [C] 20      [D] 120

477. 010630a, P.I. A.N.1  
Which equation illustrates the multiplicative inverse property?

[A]  $1 \cdot x = x$       [B]  $1 \cdot 0 = 0$   
[C]  $-1 \cdot x = -x$       [D]  $x \cdot \frac{1}{x} = 1$

478. 060528a, P.I. G.G.63  
Which equation represents a line that is perpendicular to the line whose equation is  $-2y = 3x + 7$ ?

[A]  $y = \frac{2}{3}x - 3$       [B]  $2y = 3x - 3$   
[C]  $y = \frac{3}{2}x - 3$       [D]  $y = x + 7$

479. 080433a, P.I. G.G.31  
Dylan says that all isosceles triangles are acute triangles. Mary Lou wants to prove that Dylan is *not* correct. Sketch an isosceles triangle that Mary Lou could use to show that Dylan's statement is not true. In your sketch, state the measure of *each* angle of the isosceles triangle.

480. 080717a, P.I. 7.N.3  
If  $t < \sqrt{t}$ ,  $t$  could be

[A]  $\frac{1}{2}$       [B] 2      [C] 4      [D] 0

481. 080637a, P.I. G.G.54  
Triangle  $ABC$  has coordinates  $A(2,0)$ ,  $B(1,7)$ , and  $C(5,1)$ . On the accompanying set of axes, graph, label, and state the coordinates of  $\Delta A'B'C'$ , the reflection of  $\Delta ABC$  in the  $y$ -axis.

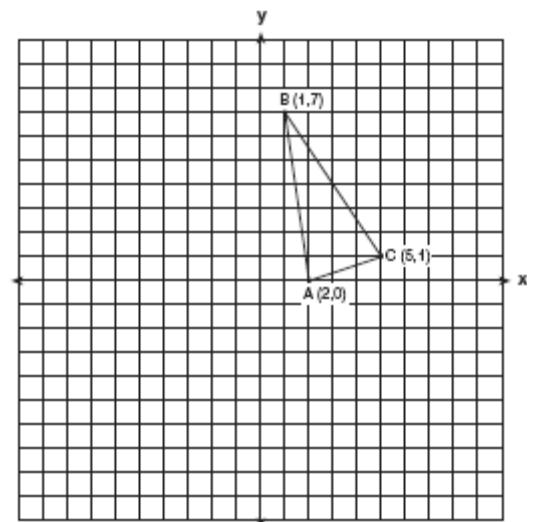

482. 089904a, P.I. 7.N.7  
Which expression is equivalent to  $6.02 \times 10^{23}$ ?

[A]  $6020 \times 10^{21}$       [B]  $602 \times 10^{21}$   
[C]  $0.602 \times 10^{21}$       [D]  $60.2 \times 10^{21}$

483. 010436a, P.I. A.A.7  
Using only 32-cent and 20-cent stamps, Charlie put \$3.36 postage on a package he sent to his sister. He used twice as many 32-cent stamps as 20-cent stamps. Determine how many of *each* type of stamp he used.

484. 080431a, P.I. 8.G.3  
Two angles are complementary. One angle has a measure that is five times the measure of the other angle. What is the measure, in degrees, of the larger angle?

485. 069914a, P.I. 7.G.1  
What is the diameter of a circle whose circumference is 5?

[A]  $\frac{5}{\pi^2}$  [B]  $\frac{5}{\pi}$  [C]  $\frac{2.5}{\pi}$  [D]  $\frac{2.5}{\pi^2}$

486. 010427a, P.I. A.A.1  
Which expression represents the number of yards in  $x$  feet?

[A]  $12x$  [B]  $\frac{x}{12}$  [C]  $3x$  [D]  $\frac{x}{3}$

487. 060022a, P.I. G.G.17  
Using only a ruler and compass, construct the bisector of angle  $BAC$  in the accompanying diagram.

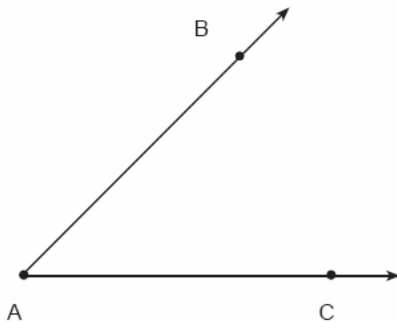

488. 080101a, P.I. G.G.45  
The perimeter of an equilateral triangle varies directly as the length of a side. When the length of a side is doubled, the perimeter of the triangle is

[A] divided by 3 [B] doubled  
[C] halved [D] multiplied by 3

489. 080506a, P.I. G.G.60  
As shown in the accompanying diagram, the star in position 1 on a computer screen transforms to the star in position 2.

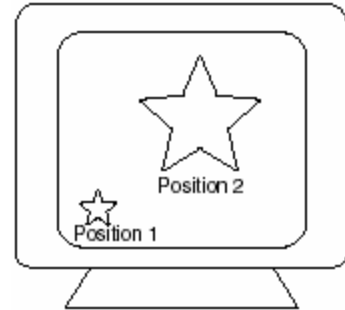

This transformation is best described as a

[A] rotation [B] dilation  
[C] line reflection [D] translation

490. 010001a, P.I. 7.N.18  
The expression  $\sqrt{93}$  is a number between  
[A] 8 and 9 [B] 46 and 47  
[C] 9 and 10 [D] 3 and 9

491. 080116a, P.I. G.G.26  
Which statement is the converse of "If it is a 300 ZX, then it is a car"?

[A] If it is not a car, then it is not a 300 ZX.  
[B] If it is a car, then it is a 300 ZX.  
[C] If it is not a 300 ZX, then it is not a car.  
[D] If it is a car, then it is not a 300 ZX.

492. 010129a, P.I. G.G.25  
Mark says, "The number I see is odd." Jan says, "That same number is prime." The teacher says, "Mark is correct or Jan is correct." Some integers would make the teacher's statement true while other integers would make it false. Give and explain one example of when the teacher's statement is true. Give and explain one example of when the teacher's statement is false.



493. 010112a, P.I. G.G.26  
Given the statement: "If two sides of a triangle are congruent, then the angles opposite these sides are congruent."  
Given the converse of the statement: "If two angles of a triangle are congruent, then the sides opposite these angles are congruent."  
What is true about this statement and its converse?
- [A] The statement is true but its converse is false.  
[B] Both the statement and its converse are true.  
[C] The statement is false but its converse is true.  
[D] Neither the statement nor its converse is true.
494. 080701a, P.I. G.G.25  
Given the true statements: " $t$  is a multiple of 3" and " $t$  is even." What could be a value of  $t$ ?
- [A] 9      [B] 24      [C] 8      [D] 15
495. 060535a, P.I. A.A.20  
Factor completely:  $3x^2 + 15x - 42$
496. 060534a, P.I. A2.S.11  
An algebra class of 21 students must send 5 students to meet with the principal. How many different groups of 5 students could be formed from this class?
497. 010812a, P.I. A.N.1  
Which property is represented by the statement  $\frac{1}{2}(6a + 4b) = 3a + 2b$ ?
- [A] commutative      [B] associative  
[C] distributive      [D] identity
498. 060632a, P.I. A2.S.11  
Five friends met for lunch, and they all shook hands. Each person shook the other person's right hand only once. What was the total number of handshakes?
499. 080406a, P.I. A.A.22  
What is the value of  $n$  in the equation  $0.6(n + 10) = 3.6$ ?
- [A] 5      [B] -4      [C] 4      [D] -0.4
500. 060720a, P.I. 7.N.5  
According to the 2000 census, the population of New York State was approximately 18,900,000. How is this number expressed in scientific notation?
- [A]  $189 \times 10^5$       [B]  $1890 \times 10^4$   
[C]  $18.9 \times 10^6$       [D]  $1.89 \times 10^7$
501. 010429a, P.I. A.A.13  
If  $2x^2 - x + 6$  is subtracted from  $x^2 + 3x - 2$ , the result is
- [A]  $x^2 + 2x - 8$       [B]  $x^2 - 4x + 8$   
[C]  $-x^2 + 2x - 8$       [D]  $-x^2 + 4x - 8$
502. 060617a, P.I. A.A.23  
The formula for the volume of a right circular cylinder is  $V = \pi r^2 h$ . The value of  $h$  can be expressed as
- [A]  $\frac{V}{\pi r^2}$       [B]  $\frac{\pi r^2}{V}$   
[C]  $V - \pi r^2$       [D]  $\frac{V}{\pi} r^2$
503. 080630a, P.I. G.G.63  
Which line is perpendicular to the line whose equation is  $5y + 6 = -3x$ ?
- [A]  $y = -\frac{5}{3}x + 7$       [B]  $y = -\frac{3}{5}x + 7$   
[C]  $y = \frac{5}{3}x + 7$       [D]  $y = \frac{3}{5}x + 7$

504. 080609a, P.I. G.G.61  
What is the image of point  $(-3, 4)$  under the translation that shifts  $(x,y)$  to  $(x-3, y+2)$ ?

- [A]  $(-6,6)$                       [B]  $(-6,8)$   
[C]  $(6,6)$                         [D]  $(0,6)$

505. 060322a, P.I. G.G.58  
The lengths of the sides of two similar rectangular billboards are in the ratio 5:4. If 250 square feet of material is needed to cover the larger billboard, how much material, in square feet, is needed to cover the smaller billboard?

506. 010133a, P.I. G.G.74  
John uses the equation  $x^2 + y^2 = 9$  to represent the shape of a garden on graph paper.  
a Graph  $x^2 + y^2 = 9$  on the accompanying grid.

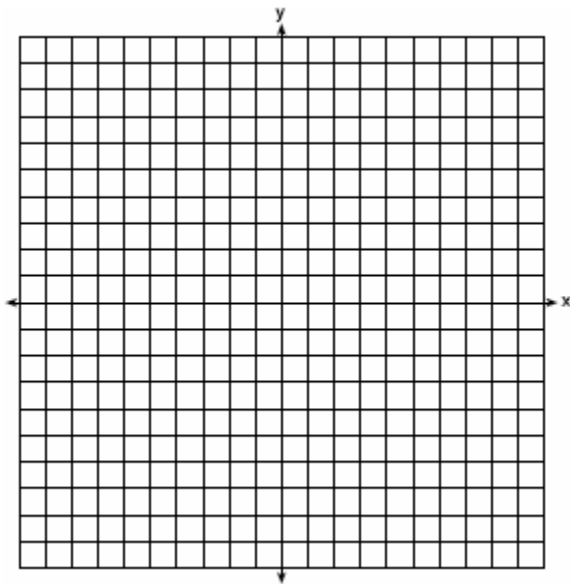

b What is the area of the garden to the nearest square unit?

507. 069906a, P.I. A.A.16  
Expressed as a single fraction, what is  $\frac{1}{x+1} + \frac{1}{x}$ ,  $x \neq 0, -1$ ?

- [A]  $\frac{2}{2x+1}$                       [B]  $\frac{2x+3}{x^2+x}$   
[C]  $\frac{3}{x^2}$                             [D]  $\frac{2x+1}{x^2+x}$

508. 060327a  
Tina's preschool has a set of cardboard building blocks, each of which measures 9 inches by 9 inches by 4 inches. How many of these blocks will Tina need to build a wall 4 inches thick, 3 feet high, and 12 feet long?

509. 080124a, P.I. A.G.1  
An engineer measured the dimensions for a rectangular site by using a wooden pole of unknown length  $x$ . The length of the rectangular site is 2 pole measures increased by 3 feet, while the width is 1 pole measure decreased by 4 feet. Write an algebraic representation, in terms of  $x$ , for the perimeter of the site.

510. 060522a, P.I. A.N.6  
If  $r = 2$  and  $s = -7$ , what is the value of  $|r| - |s|$ ?

- [A] 5                      [B] 9                      [C] -9                      [D] -5

511. 010509a, P.I. G.G.61  
The image of point  $(3,-5)$  under the translation that shifts  $(x,y)$  to  $(x-1, y-3)$  is

- [A]  $(2,-8)$                       [B]  $(-4,8)$   
[C]  $(-3,15)$                       [D]  $(2,8)$

512. 080425a, P.I. G.G.33  
Which set can *not* represent the lengths of the sides of a triangle?

- [A]  $\{8,8,8\}$                       [B]  $\{7,7,12\}$   
[C]  $\{4,5,6\}$                       [D]  $\{5,5,11\}$

513. 010326a, P.I. A.A.8  
Three brothers have ages that are consecutive even integers. The product of the first and third boys' ages is 20 more than twice the second boy's age. Find the age of *each* of the three boys.

514. 080411a, P.I. 8.G.19  
Which inequality is represented in the accompanying graph?



- [A]  $-3 < x < 4$       [B]  $-3 \leq x \leq 4$   
[C]  $-3 < x \leq 4$       [D]  $-3 \leq x < 4$
515. 010404a  
Which statement about quadrilaterals is true?  
[A] All quadrilaterals have equal sides.  
[B] All quadrilaterals are parallelograms.  
[C] All quadrilaterals have four sides.  
[D] All quadrilaterals have four right angles.

516. 060419a, P.I. A.A.44  
The angle of elevation from a point 25 feet from the base of a tree on level ground to the top of the tree is  $30^\circ$ . Which equation can be used to find the height of the tree?

- [A]  $\sin 30^\circ = \frac{x}{25}$       [B]  $30^2 + 25^2 = x^2$   
[C]  $\cos 30^\circ = \frac{x}{25}$       [D]  $\tan 30^\circ = \frac{x}{25}$

517. 080220a  
In the graph of  $y \leq -x$ , which quadrant is completely shaded?  
[A] I      [B] II      [C] IV      [D] III

518. 080129a, P.I. A.N.1  
Ramón said that the set of integers is *not* closed for one of the basic operations (addition, subtraction, multiplication, or division). You want to show Ramón that his statement is correct. For the operation for which the set of integers is *not* closed, write an example using:

- o a positive even integer and a zero
- o a positive and a negative even integer
- o two negative even integers

Be sure to explain why *each* of your examples illustrates that the set of integers is *not* closed for that operation.

519. 080223a, P.I. A.A.26  
An image of a building in a photograph is 6 centimeters wide and 11 centimeters tall. If the image is similar to the actual building and the actual building is 174 meters wide, how tall is the actual building, in meters?

520. 080429a, P.I. A.A.10  
What point is the intersection of the graphs of the lines  $2x - y = 3$  and  $x + y = 3$ ?

- [A] (3, 0)      [B] (3, 3)  
[C] (1, 2)      [D] (2, 1)

521. 080215a  
Which piece of paper can be folded into a pyramid?

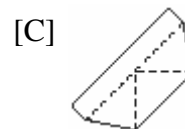
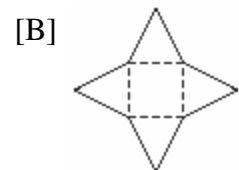
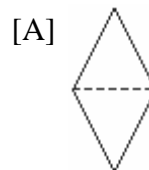

522. 080507a, P.I. G.G.37

A stop sign in the shape of a regular octagon is resting on a brick wall, as shown in the accompanying diagram.

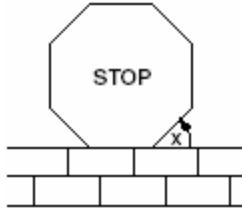

What is the measure of angle  $x$ ?

- [A]  $135^\circ$  [B]  $120^\circ$  [C]  $60^\circ$  [D]  $45^\circ$

523. 069922a, P.I. A.A.23

Shoe sizes and foot length are related by the formula  $S = 3F - 24$ , where  $S$  represents the shoe size and  $F$  represents the length of the foot, in inches.

*a* Solve the formula for  $F$ .

*b* To the *nearest tenth of an inch*, how long is the foot of a person who wears a size  $10\frac{1}{2}$  shoe?

524. 080102a, P.I. 7.N.2

Which expression is rational?

- [A]  $\sqrt{3}$  [B]  $\pi$  [C]  $\sqrt{\frac{1}{4}}$  [D]  $\sqrt{\frac{1}{2}}$

525. 060537a, P.I. G.G.54

On the accompanying set of axes, draw the reflection of  $ABCD$  in the  $y$ -axis. Label and state the coordinates of the reflected figure.

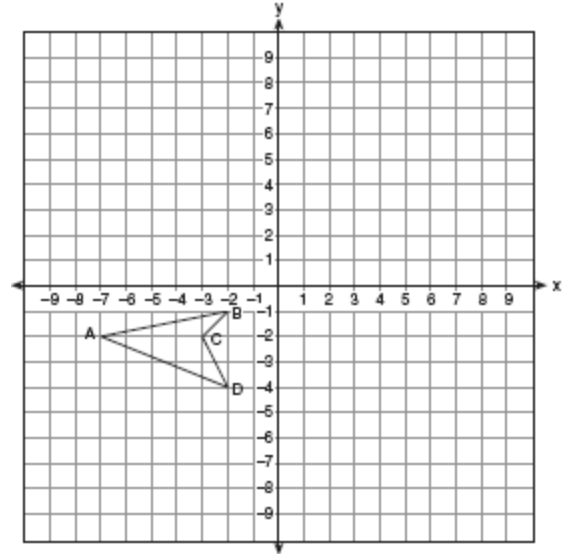

526. 010507a, P.I. A.A.22

What is the solution set of the equation

$$\frac{x}{5} + \frac{x}{2} = 14 ?$$

- [A] {10} [B] {49} [C] {4} [D] {20}

527. 060301a, P.I. 7.N.6

The number  $8.375 \times 10^{-3}$  is equivalent to

- [A] 0.08375 [B] 0.0008375  
[C] 8,375 [D] 0.008375

528. 010003a, P.I. G.G.25

Mary says, "The number I am thinking of is divisible by 2 or it is divisible by 3." Mary's statement is false if the number she is thinking of is

- [A] 11 [B] 8 [C] 15 [D] 6

529. 080728a

Line segment  $AB$  has a slope of  $\frac{3}{4}$ . If the coordinates of point  $A$  are  $(2,5)$ , the coordinates of point  $B$  could be

- [A]  $(6,8)$                       [B]  $(-1,1)$   
[C]  $(5,9)$                       [D]  $(6,2)$

530. 010522a, P.I. A.A.38

Which equation represents a line that is parallel to the line whose equation is  $2x + 3y = 12$ ?

- [A]  $6y + 4x = 2$               [B]  $6x + 4y = -2$   
[C]  $4x - 6y = 2$               [D]  $6y - 4x = 2$

531. 010307a, P.I. A2.S.9

There are 12 people on a basketball team, and the coach needs to choose 5 to put into a game. How many different possible ways can the coach choose a team of 5 if each person has an equal chance of being selected?

- [A]  ${}_{12}P_5$     [B]  ${}_{12}C_5$     [C]  ${}_5C_{12}$     [D]  ${}_5P_{12}$

532. 080739a, P.I. G.G.26

Given the statement: "If I live in Albany, then I am a New Yorker."

In the spaces provided below, write the inverse, the converse, and the contrapositive of this statement.

Inverse: \_\_\_\_\_

\_\_\_\_\_

Converse: \_\_\_\_\_

\_\_\_\_\_

Contrapositive: \_\_\_\_\_

\_\_\_\_\_

Which conditional is logically equivalent to its original statement?

inverse      converse      contrapositive

533. 080611a

Which transformation does *not* always result in an image that is congruent to the original figure?

- [A] dilation                      [B] translation  
[C] rotation                      [D] reflection

534. 010818a, P.I. A.A.26

On a map, 1 inch represents 3 miles. How many miles long is a road that is  $2\frac{1}{2}$  inches long on the map?

- [A]  $\frac{1}{2}$     [B]  $5\frac{1}{2}$     [C]  $7\frac{1}{2}$     [D]  $6\frac{1}{2}$

535. 010716a, P.I. A.A.15  
Which expression is undefined when  $w = 3$ ?

[A]  $\frac{w-3}{w+1}$                       [B]  $\frac{3w}{3w^2}$   
[C]  $\frac{w+1}{w^2-3w}$                       [D]  $\frac{w^2+2w}{5w}$

536. 060411a, P.I. G.G.45  
Delroy's sailboat has two sails that are similar triangles. The larger sail has sides of 10 feet, 24 feet, and 26 feet. If the shortest side of the smaller sail measures 6 feet, what is the perimeter of the *smaller* sail?

[A] 15 ft                      [B] 36 ft  
[C] 100 ft                      [D] 60 ft

537. 010408a, P.I. 8.G.16  
An equation of the line that has a slope of 3 and a y-intercept of -2 is

[A]  $y = -x$                       [B]  $y = 3x - 2$   
[C]  $x = 3y - 2$                       [D]  $y = -2x + 3$

538. 060215a, P.I. G.G.58  
If the circumference of a circle is doubled, the diameter of the circle

[A] is multiplied by 4  
[B] increases by 2  
[C] is doubled                      [D] remains the same

539. 080437a, P.I. A.S.5  
The following set of data represents the scores on a mathematics quiz:  
58, 79, 81, 99, 68, 92, 76, 84, 53, 57, 81, 91,  
77, 50, 65, 57, 51, 72, 84, 89

Complete the frequency table below and, on the accompanying grid, draw and label a frequency histogram of these scores.

**Mathematics Quiz Scores**

Interval	Tally	Frequency
50-59		
60-69		
70-79		
80-89		
90-99		

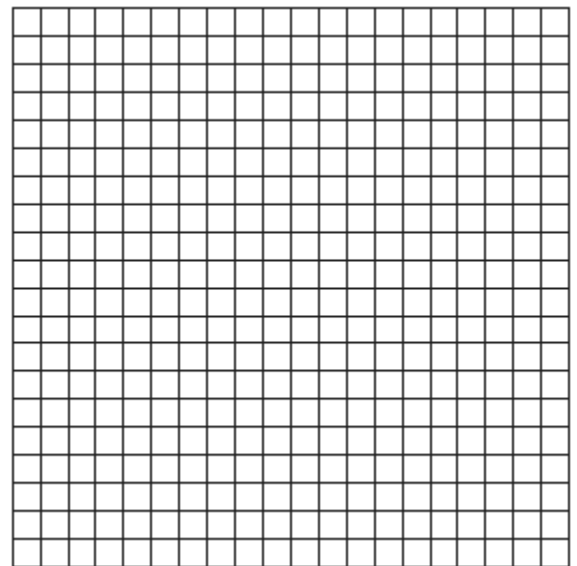

540. 010530a, P.I. A.N.2  
When  $\sqrt{72}$  is expressed in simplest  $a\sqrt{b}$  form, what is the value of  $a$ ?

[A] 8                      [B] 6                      [C] 3                      [D] 2

541. 069917a, P.I. 7.N.3  
If  $t^2 < t < \sqrt{t}$ , then  $t$  could be

[A] 4                      [B]  $-\frac{1}{4}$                       [C] 0                      [D]  $\frac{1}{4}$

542. 080725a, P.I. A.N.1  
Which equation illustrates the associative property?

[A]  $(a + b) + c = a + (b + c)$   
[B]  $a(1) = a$                       [C]  $a + b = b + a$   
[D]  $a(b + c) = (ab) + (ac)$

543. 010302a, P.I. G.G.59  
Triangle  $A'B'C'$  is the image of  $\triangle ABC$  under a dilation such that  $A'B' = 3AB$ . Triangles  $ABC$  and  $A'B'C'$  are

[A] neither congruent nor similar  
[B] similar but not congruent  
[C] both congruent and similar  
[D] congruent but not similar

544. 060213a, P.I. G.G.37  
What is the measure, in degrees, of each exterior angle of a regular hexagon?

[A] 120    [B] 45    [C] 135    [D] 60

545. 060225a  
Write the equation for the line shown in the accompanying graph. Explain your answer.

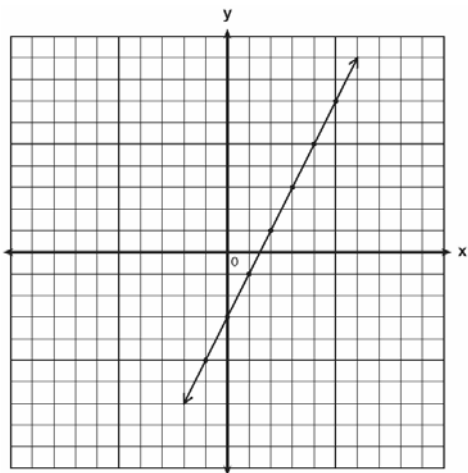

546. 060218a, P.I. A.N.3  
The expression  $\sqrt{90} \cdot \sqrt{40} - \sqrt{8} \cdot \sqrt{18}$  simplifies to

[A] 48    [B] 864    [C] 22.9    [D] 3,456

547. 010524a, P.I. G.G.67  
The coordinates of point  $R$  are  $(-3, 2)$  and the coordinates of point  $T$  are  $(4, 1)$ . What is the length of  $\overline{RT}$ ?

[A]  $5\sqrt{2}$                                       [B]  $2\sqrt{2}$   
[C]  $4\sqrt{3}$                                       [D]  $\sqrt{10}$

548. 010125a, P.I. A.A.6  
Two trains leave the same station at the same time and travel in opposite directions. One train travels at 80 kilometers per hour and the other at 100 kilometers per hour. In how many hours will they be 900 kilometers apart?

549. 010534a, P.I. G.G.33  
José wants to build a triangular pen for his pet rabbit. He has three lengths of boards already cut that measure 7 feet, 8 feet, and 16 feet. Explain why José cannot construct a pen in the shape of a triangle with sides of 7 feet, 8 feet, and 16 feet.

550. 089911a, P.I. A.A.17  
Which expression is equivalent to  $\frac{a}{x} + \frac{b}{2x}$ ?

[A]  $\frac{2a + b}{2x}$                                       [B]  $\frac{a + b}{3x}$   
[C]  $\frac{a + b}{2x}$                                       [D]  $\frac{2a + b}{x}$

551. 010713a, A2.S.10  
Which value is equivalent to  ${}_3P_3$ ?

[A] 3!    [B] 9    [C] 1    [D] 27

552. 080430a, P.I. A.S.23  
Selena and Tracey play on a softball team. Selena has 8 hits out of 20 times at bat, and Tracey has 6 hits out of 16 times at bat. Based on their past performance, what is the probability that both girls will get a hit next time at bat?  
[A] 1      [B]  $\frac{31}{40}$       [C]  $\frac{14}{36}$       [D]  $\frac{48}{320}$
553. 060619a, P.I. G.G.22  
Chantrice is pulling a wagon along a smooth, horizontal street. The path of the center of one of the wagon wheels is best described as  
[A] a circle  
[B] a line perpendicular to the road  
[C] a line parallel to the road  
[D] two parallel lines
554. 010407a  
Given the true statements: "Jason goes shopping or he goes to the movies" and "Jason does not go to the movies." Which statement must also be true?  
[A] Jason goes shopping.  
[B] Jason stays home.  
[C] Jason does not go shopping.  
[D] Jason does not go shopping and he does not go to the movies.
555. 089912a, P.I. G.G.26  
What is true about the statement "If two angles are right angles, the angles have equal measure " and its converse "If two angles have equal measure then the two angles are right angles"?"  
[A] Both the statement and its converse are true.  
[B] Both the statement and its converse are false.  
[C] The statement is false but its converse is true.  
[D] The statement is true but its converse is false.
556. 080511a, P.I. 7.N.5  
The expression  $0.62 \times 10^3$  is equivalent to  
[A] 62,000      [B] 0.062  
[C]  $6.2 \times 10^4$       [D]  $6.2 \times 10^2$
557. 080528a  
The graph of the equation  $x^2 + y^2 = 4$  can be described as a  
[A] circle with its center at the origin and a radius of 2  
[B] parabola with its vertex at (0,2)  
[C] circle with its center at the origin and a radius of 4  
[D] line passing through points (0,2) and (2,0)



558. 060330a  
To get from his high school to his home, Jamal travels 5.0 miles east and then 4.0 miles north. When Sheila goes to her home from the same high school, she travels 8.0 miles east and 2.0 miles south. What is the measure of the shortest distance, to the *nearest tenth of a mile*, between Jamal's home and Sheila's home? [The use of the accompanying grid is optional.]

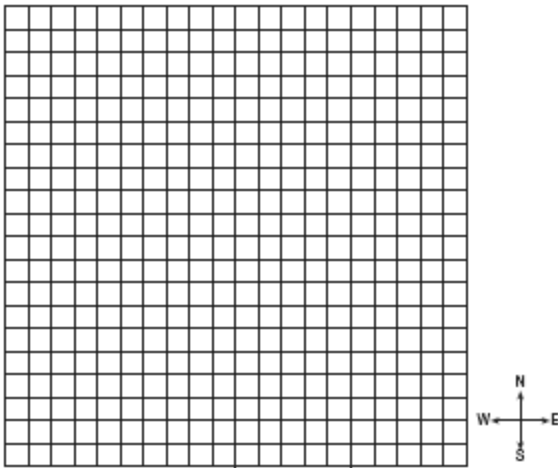

559. 010637a, P.I. A.A.27  
Solve for  $x$ :  $x^2 + 2x - 24 = 0$
560. 080014a, P.I. G.G.26  
What is the converse of the statement "If it is sunny, I will go swimming"?
- [A] If I do not go swimming, then it is not sunny.  
[B] I will go swimming if and only if it is sunny.  
[C] If I go swimming, it is sunny.  
[D] If it is not sunny, I will not go swimming.
561. 060706a  
The expression  $\sqrt{54 - b}$  is equivalent to a positive integer when  $b$  is equal to
- [A] 54    [B] -10    [C] 4    [D] 16

562. 060329a, P.I. A.N.8  
A certain state is considering changing the arrangement of letters and numbers on its license plates. The two options the state is considering are:  
Option 1: three letters followed by a four-digit number with repetition of both letters and digits allowed  
Option 2: four letters followed by a three-digit number without repetition of either letters or digits  
[Zero may be chosen as the first digit of the number in either option.]  
Which option will enable the state to issue more license plates? How many *more* different license plates will that option yield?
563. 060607a, P.I. A2.S.9  
Leo purchased five shirts, three pairs of pants, and four pairs of shoes. Which expression represents how many different outfits consisting of one shirt, one pair of pants, and one pair of shoes Leo can make?
- [A]  $5 + 3 + 4$                       [B]  ${}_{12}P_3$   
[C]  ${}_{12}C_3$                               [D]  $5 \cdot 3 \cdot 4$
564. 010506a, P.I. A.A.1  
If  $n + 4$  represents an odd integer, the next larger odd integer is represented by
- [A]  $n + 3$                               [B]  $n + 6$   
[C]  $n + 2$                               [D]  $n + 5$
565. 010810a  
If the measures, in degrees, of the three angles of a triangle are  $x$ ,  $x + 10$ , and  $2x - 6$ , the triangle must be
- [A] right                                  [B] equilateral  
[C] scalene                                [D] isosceles
566. 010431a, P.I. A.N.5  
Julio's wages vary directly as the number of hours that he works. If his wages for 5 hours are \$29.75, how much will he earn for 30 hours?

567. 080631a, P.I. A.RP.11  
In Clark Middle School, there are 60 students in seventh grade. If 25 of these students take art only, 18 take music only, and 9 do not take either art or music, how many take both art and music?

568. 010824a, P.I. A.A.1  
The larger of two consecutive integers is represented by  $x + 4$ . Which expression represents the *smaller* integer?

- [A]  $x + 5$                       [B]  $x + 3$   
[C]  $x + 6$                       [D]  $x + 2$

569. 060620a, P.I. A.A.40  
Which coordinate point is in the solution set for the system of inequalities shown in the accompanying graph?

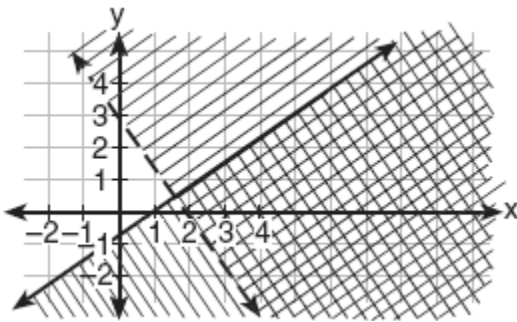

- [A] (1,-1)                      [B] (3,1)  
[C] (2,2)                      [D] (0,1)

570. 060311a, P.I. A.A.21  
Which number is in the solution set of the inequality  $5x + 3 > 38$ ?

- [A] 7            [B] 6            [C] 8            [D] 5

571. 010621a, P.I. A.RP.11  
The accompanying Venn diagram shows the results of a survey asking 100 people if they get news by reading newspapers or by watching television.

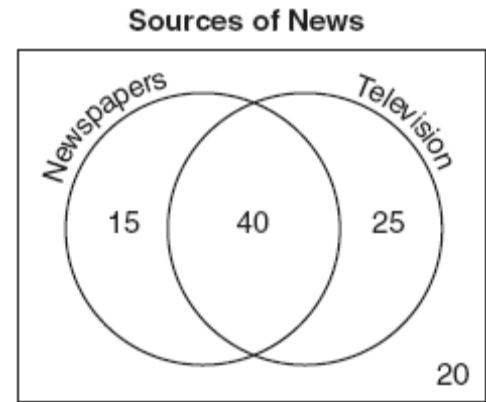

What is the probability that a person selected at random from this survey does *not* claim television as a source of getting the news?

- [A]  $\frac{55}{100}$     [B]  $\frac{75}{100}$     [C]  $\frac{35}{100}$     [D]  $\frac{15}{100}$

572. 080537a  
In the accompanying diagram, the perimeter of  $\triangle MNO$  is equal to the perimeter of square ABCD. If the sides of the triangle are represented by  $4x + 4$ ,  $5x - 3$ , and 17, and one side of the square is represented by  $3x$ , find the length of a side of the square.

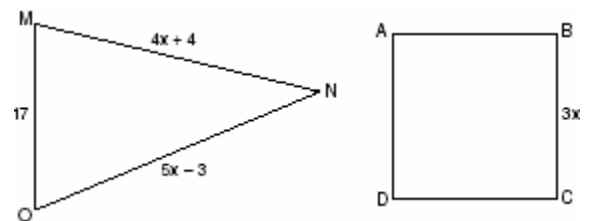

573. 010439a, P.I. A.G.4

Tom throws a ball into the air. The ball travels on a parabolic path represented by the equation  $h = -8t^2 + 40t$ , where  $h$  is the height, in feet, and  $t$  is the time, in seconds.

*a* On the accompanying set of axes, graph the equation from  $t=0$  to  $t=5$  seconds, including all integral values of  $t$  from 0 to 5.

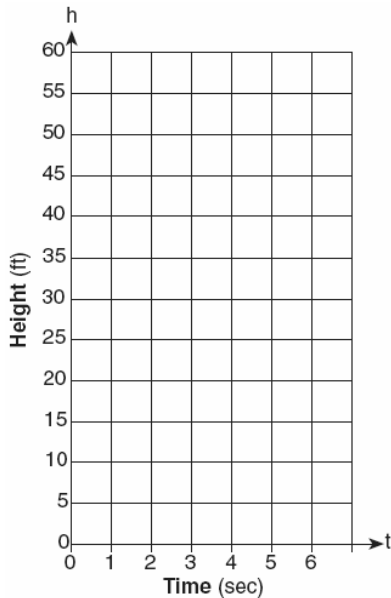

*b* What is the value of  $t$  at which  $h$  has its greatest value?

574. 069908a, P.I. G.G.61

If  $x = -3$  and  $y = 2$ , which point on the accompanying graph represents  $(-x, -y)$ ?

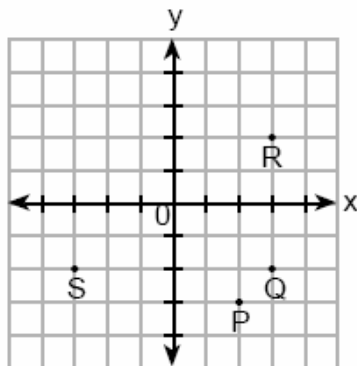

- [A] C      [B] D      [C] A      [D] B

575. 060724a, P.I. A.N.3

The expression  $\sqrt{28} + \sqrt{63}$  is equivalent to

- [A]  $6\sqrt{7}$                       [B]  $5\sqrt{7}$   
[C]  $13\sqrt{7}$                     [D]  $\sqrt{91}$

576. 010718a

The midpoint of  $\overline{AB}$  is  $(-1,5)$  and the coordinates of point  $A$  are  $(-3,2)$ . What are the coordinates of point  $B$ ?

- [A]  $(-5,8)$                       [B]  $(1,8)$   
[C]  $(0,7)$                         [D]  $(1,10)$

577. 089923a, P.I. A.N.7

Paloma has 3 jackets, 6 scarves, and 4 hats. Determine the number of different outfits consisting of a jacket, a scarf, and a hat that Paloma can wear.

578. 060209a

Which letter has point symmetry?

- [A] H      [B] A      [C] W      [D] B

579. 080130a, P.I. G.G.63

Shanaya graphed the line represented by the equation  $y = x - 6$ . Write an equation for a line that is parallel to the given line. Write an equation for a line that is perpendicular to the given line. Write an equation for a line that is identical to the given line but has different coefficients.

580. 010728a, P.I. A.A.12

The expression  $(6x^3y^6)^2$  is equivalent to

- [A]  $36x^6y^{12}$                       [B]  $6x^6y^{12}$   
[C]  $36x^5y^8$                         [D]  $12x^6y^{12}$

581. 080015a, P.I. A.A.22

Solve for  $x$ :  $15x - 3(3x + 4) = 6$

- [A] 1      [B]  $\frac{1}{3}$       [C]  $-\frac{1}{2}$       [D] 3

582. 080601a, P.I. A.N.1  
While solving the equation  $4(x + 2) = 28$ ,  
Becca wrote  $4x + 8 = 28$ . Which property did  
she use?
- [A] associative            [B] commutative  
[C] distributive        [D] identity

583. 010122a, P.I. A.N.5  
Sue bought a picnic table on sale for 50% off  
the original price. The store charged her 10%  
tax and her final cost was \$22.00. What was  
the original price of the picnic table?

584. 010627a, P.I. G.G.26  
Which statement is expressed as a  
biconditional?
- [A] Two angles are congruent if they have the  
same measure.  
[B] If two angles are congruent, then they are  
both right angles.  
[C] Two angles are congruent if and only if  
they have the same measure.  
[D] If two angles are both right angles, then  
they are congruent.

585. 080203a, P.I. G.G.22  
What is the total number of points equidistant  
from two intersecting straight roads and also  
300 feet from the traffic light at the center of  
the intersection?
- [A] 2            [B] 4            [C] 0            [D] 1

586. 080127a, P.I. A.S.23  
There are four students, all of different  
heights, who are to be randomly arranged in a  
line. What is the probability that the tallest  
student will be first in line and the shortest  
student will be last in line?

587. 080128a, P.I. G.G.58  
On the accompanying set of axes, graph  
 $\triangle ABC$  with coordinates  $A(-1,2)$ ,  $B(0,6)$ , and  
 $C(5,4)$ . Then graph  $\triangle A'B'C'$ , the image of  
 $\triangle ABC$  after a dilation of 2.

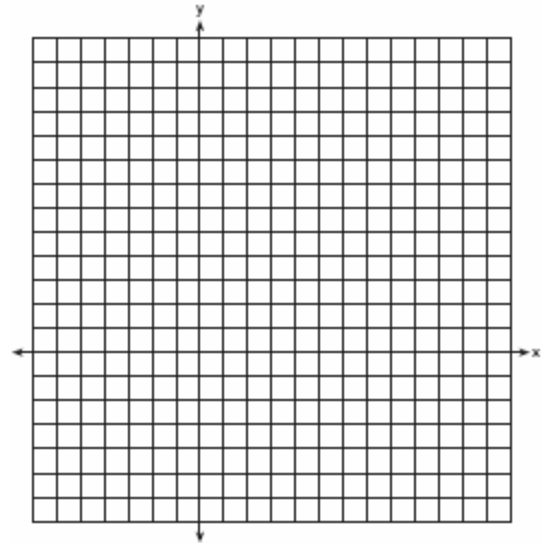

588. 080526a, P.I. A.A.12  
The expression  $\frac{5x^6y^2}{x^8y}$  is equivalent to

- [A]  $\frac{5y^3}{x^{14}}$                             [B]  $5x^{14}y^3$   
[C]  $5x^2y$                             [D]  $\frac{5y}{x^2}$

589. 010811a, P.I. A.S.20  
Which event has a probability of zero?
- [A] choosing a number that is greater than 6  
and is even  
[B] choosing a pair of parallel lines that have  
unequal slopes  
[C] choosing a letter from the alphabet that  
has line symmetry  
[D] choosing a triangle that is both isosceles  
and right



598. 060118a, P.I. A.A.21  
In the set of positive integers, what is the solution set of the inequality  $2x - 3 < 5$ ?
- [A] {1, 2, 3}                      [B] {1, 2, 3, 4}  
[C] {0, 1, 2, 3}                  [D] {0, 1, 2, 3, 4}
599. 010501a, P.I. G.G.25  
Stan was trying to guess Melanie's age. She told him her age was an even number and a multiple of three. What could be Melanie's age?
- [A] 10      [B] 16      [C] 12      [D] 15
600. 060721a, P.I. A.A.39  
The graph of the equation  $2x + 6y = 4$  passes through point  $(x, -2)$ . What is the value of  $x$ ?
- [A] -4      [B] 4      [C] 16      [D] 8
601. 010620a, P.I. A.A.23  
In the equation  $A = p + prt$ ,  $t$  is equivalent to
- [A]  $\frac{A - pr}{p}$                       [B]  $\frac{A}{pr} - p$   
[C]  $\frac{A - p}{pr}$                       [D]  $\frac{A}{p} - pr$
602. 069925a, P.I. A.A.6  
Sara's telephone service costs \$21 per month plus \$0.25 for each local call, and long-distance calls are extra. Last month, Sara's bill was \$36.64, and it included \$6.14 in long-distance charges. How many local calls did she make?
603. 080023a, P.I. A.G.1  
Kerry is planning a rectangular garden that has dimensions of 4 feet by 6 feet. Kerry wants one-half of the garden to have roses, and she says that the rose plot will have dimensions of 2 feet by 3 feet. Is she correct? Explain.

604. 010626a, P.I. A.N.5  
The Edison Lightbulb Company tests 5% of their daily production of lightbulbs. If 500 bulbs were tested on Tuesday, what was the total number of bulbs produced that day?
- [A] 25                                  [B] 1,000  
[C] 10,000                          [D] 100,000
605. 010330a, P.I. A.G.1  
A rectangular garden is going to be planted in a person's rectangular backyard, as shown in the accompanying diagram. Some dimensions of the backyard and the width of the garden are given. Find the area of the garden to the nearest square foot.

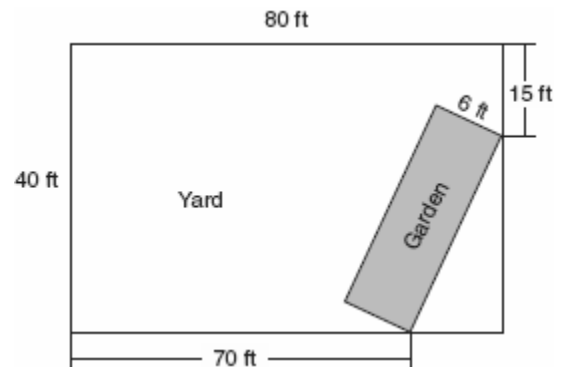

606. 080614a, P.I. A.N.3  
What is the sum of  $\sqrt{50}$  and  $\sqrt{32}$ ?
- [A]  $20\sqrt{20}$                       [B]  $\sqrt{82}$   
[C]  $\sqrt{2}$                               [D]  $9\sqrt{2}$
607. 089918a, P.I. G.G.58  
The ratio of the corresponding sides of two similar squares is 1 to 3. What is the ratio of the area of the smaller square to the area of the larger square?
- [A] 1:9      [B]  $1:\sqrt{3}$       [C] 1:3      [D] 1:6

608. 060011a, P.I. A.N.1

If  $a \neq 0$  and the sum of  $x$  and  $\frac{1}{a}$  is 0, then

[A]  $x = 1 - a$                       [B]  $x = -a$

[C]  $x = -\frac{1}{a}$                       [D]  $x = a$

609. 010230a, P.I. A.A.6

The students in Woodland High School's meteorology class measured the noon temperature every schoolday for a week. Their readings for the first 4 days were Monday,  $56^\circ$ ; Tuesday,  $72^\circ$ ; Wednesday,  $67^\circ$ ; and Thursday,  $61^\circ$ . If the mean (average) temperature for the 5 days was exactly  $63^\circ$ , what was the temperature on Friday?

610. 080426a

Which equation represents the locus of points 4 units from the origin?

[A]  $x = 4$                       [B]  $x^2 + y^2 = 4$

[C]  $x^2 + y^2 = 16$                       [D]  $x + y = 16$

611. 089910a

On June 17, the temperature in New York City ranged from  $90^\circ$  to  $99^\circ$ , while the temperature in Niagara Falls ranged from  $60^\circ$  to  $69^\circ$ . The difference in the temperatures in these two cities must be between

[A]  $20^\circ$  and  $30^\circ$                       [B]  $20^\circ$  and  $40^\circ$

[C]  $25^\circ$  and  $35^\circ$                       [D]  $30^\circ$  and  $40^\circ$

612. 010828a, P.I. A.G.6

Which inequality is shown in the accompanying diagram?

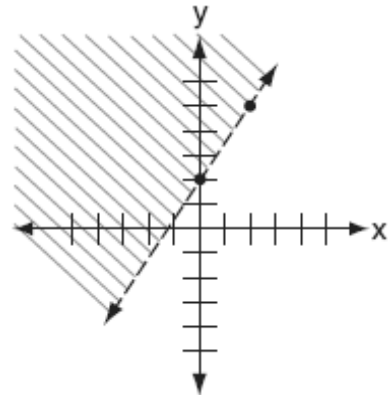

[A]  $y \geq \frac{3}{2}x + 2$                       [B]  $y > \frac{3}{2}x + 2$

[C]  $y < \frac{3}{2}x + 2$                       [D]  $y \leq \frac{3}{2}x + 2$

613. 010016a, P.I. A.A.17

The expression  $\frac{y}{x} - \frac{1}{2}$  is equivalent to

[A]  $\frac{1-y}{2x}$                       [B]  $\frac{y-1}{x-2}$

[C]  $\frac{2y-x}{2x}$                       [D]  $\frac{x-2y}{2x}$

614. 080704a, P.I. A2.S.9

Jen and Barry's ice cream stand has three types of cones, six flavors of ice cream, and four kinds of sprinkles. If a serving consists of a cone, one flavor of ice cream, and one kind of sprinkles, how many different servings are possible?

[A]  ${}_{13}C_3$     [B] 72    [C] 90    [D]  ${}_{13}P_3$

615. 089924a, P.I. 7.S.6  
In a recent poll, 600 people were asked whether they liked Chinese food. A circle graph was constructed to show the results. The central angles for two of the three sectors are shown in the accompanying diagram. How many people had no opinion?

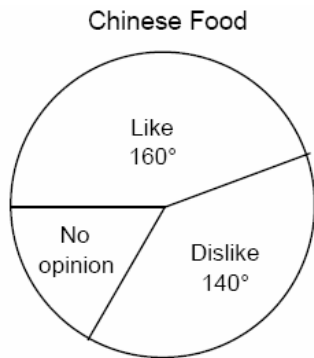

616. 080625a  
What is the total number of points of intersection of the graphs of the equations  $x^2 + y^2 = 16$  and  $y = x$ ?
- [A] 1      [B] 4      [C] 2      [D] 3

617. 080235a, P.I. G.G.68  
Determine the distance between point  $A(-1,-3)$  and point  $B(5,5)$ . Write an equation of the perpendicular bisector of  $\overline{AB}$ . [The use of the accompanying grid is optional.]

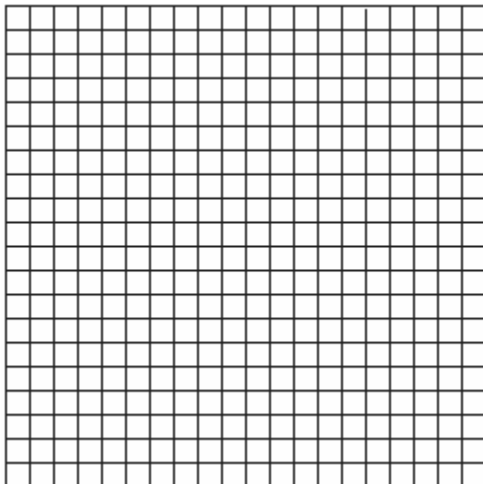

618. 010210a, P.I. A.A.26  
There are 357 seniors in Harris High School. The ratio of boys to girls is 7:10. How many boys are in the senior class?

[A] 210    [B] 117    [C] 107    [D] 147

619. 010418a, P.I. G.G.61  
In the accompanying graph, if point  $P$  has coordinates  $(a,b)$ , which point has coordinates  $(-b,a)$ ?

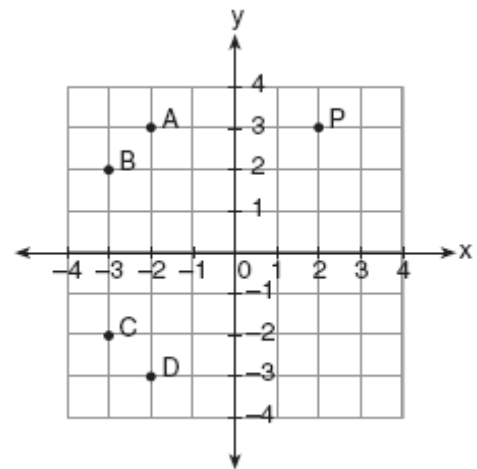

[A] A      [B] C      [C] D      [D] B

620. 060009a, P.I. G.G.48  
The set of integers  $\{3,4,5\}$  is a Pythagorean triple. Another such set is

[A]  $\{8,15,17\}$       [B]  $\{6,8,12\}$   
[C]  $\{6,12,13\}$       [D]  $\{6,7,8\}$



621. 069934a, P.I. A.A.44  
Joe is holding his kite string 3 feet above the ground, as shown in the accompanying diagram. The distance between his hand and a point directly under the kite is 95 feet. If the angle of elevation to the kite is  $50^\circ$ , find the height,  $h$ , of his kite, to the nearest foot.

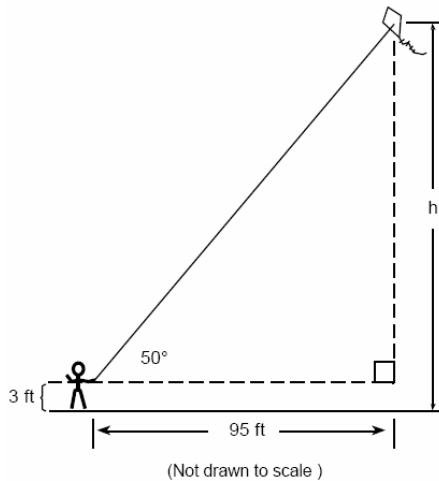

622. 010513a, P.I. G.G.26  
Which statement is logically equivalent to the statement "If you are an elephant, then you do not forget"?
- [A] If you forget, then you are not an elephant.
- [B] If you do not forget, then you are an elephant.
- [C] If you do not forget, then you are not an elephant.
- [D] If you are an elephant, then you forget.

623. 060636a, P.I. A.A.8  
Tamara has two sisters. One of the sisters is 7 years older than Tamara. The other sister is 3 years younger than Tamara. The product of Tamara's sisters' ages is 24. How old is Tamara?

624. 060611a, P.I. A.G.1  
The second side of a triangle is two more than the first side, and the third side is three less than the first side. Which expression represents the perimeter of the triangle?
- [A]  $2x - 1$                       [B]  $x + 5$
- [C]  $x^2 - x - 6$                 [D]  $3x - 1$

625. 060434a  
The coordinates of the midpoint of  $\overline{AB}$  are  $(2,4)$ , and the coordinates of point  $B$  are  $(3,7)$ . What are the coordinates of point  $A$ ? [The use of the accompanying grid is optional.]

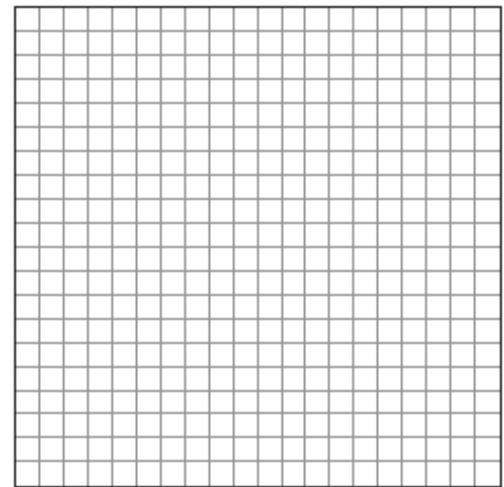

626. 010202a, P.I. A.A.45  
If the length of the legs of a right triangle are 5 and 7, what is the length of the hypotenuse?
- [A]  $\sqrt{74}$                       [B]  $2\sqrt{6}$
- [C]  $2\sqrt{3}$                       [D]  $\sqrt{2}$

627. 060217a, P.I. 7.N.11  
The expression  $15 - 3[2 + 6(-3)]$  simplifies to
- [A] -45    [B] -33    [C] 192    [D] 63

628. 080213a, P.I. A.A.6  
How many times larger than  $\frac{1}{4}x$  is  $5x$ ?
- [A] 20    [B] 9    [C]  $\frac{5}{4}$     [D]  $\frac{4}{5}$

629. 080110a, P.I. A.A.6  
The exact average of a set of six test scores is 92. Five of these scores are 90, 98, 96, 94, and 85. What is the other test score?

[A] 86 [B] 89 [C] 92 [D] 91

630. 060415a, P.I. A.S.20  
Mary chooses an integer at random from 1 to 6. What is the probability that the integer she chooses is a prime number?

[A]  $\frac{2}{6}$  [B]  $\frac{3}{6}$  [C]  $\frac{5}{6}$  [D]  $\frac{4}{6}$

631. 080427a, P.I. G.G.26  
What is the contrapositive of the statement "If I study, then I pass the test"?

[A] If I do not study, then I do not pass the test.

[B] If I do not pass the test, then I do not study.

[C] I pass the test if I study.

[D] If I pass the test, then I study.

632. 010504a, P.I. A.S.9  
The accompanying histogram shows the heights of the students in Kyra's health class.

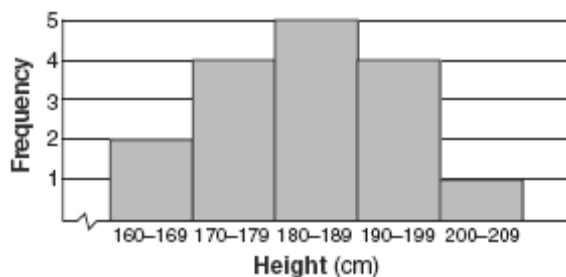

What is the total number of students in the class?

[A] 209 [B] 15 [C] 5 [D] 16

633. 080619a, P.I. A.A.39  
The graph of the equation  $x + 3y = 6$  intersects the y-axis at the point whose coordinates are

[A] (0,6) [B] (0,2)

[C] (0,18) [D] (6,0)

634. 060002a  
Which geometric figure has one and only one line of symmetry?



Rhombus

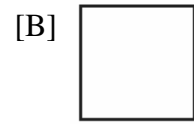

Square



Rectangle

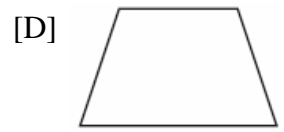

Isosceles trapezoid

635. 060019a, P.I. A.A.13  
If  $2x^2 - 4x + 6$  is subtracted from  $5x^2 + 8x - 2$ , the difference is

[A]  $-3x^2 - 12x + 8$  [B]  $3x^2 + 4x + 4$

[C]  $-3x^2 + 4x + 4$  [D]  $3x^2 + 12x - 8$

636. 010804a, P.I. G.G.60  
In the accompanying diagram, figure B is the image of figure A.



A



B

Which type of transformation was performed?

[A] dilation [B] rotation

[C] reflection [D] translation

637. 010605a  
What is the  $y$ -intercept of the graph of the line whose equation is  $y = -\frac{2}{5}x + 4$ ?

- [A] 4    [B]  $-\frac{2}{5}$     [C] 0    [D]  $-\frac{5}{2}$

638. 010733a, P.I. A.A.6  
Every month, Omar buys pizzas to serve at a party for his friends. In May, he bought three more than twice the number of pizzas he bought in April. If Omar bought 15 pizzas in May, how many pizzas did he buy in April?

639. 089907a, P.I. A.N.1  
Which equation is an illustration of the additive identity property?

- [A]  $x \cdot \frac{1}{x} = 1$     [B]  $x \cdot 1 = x$   
[C]  $x - x = 0$     [D]  $x + 0 = x$

640. 010306a, P.I. A.A.12  
The product of  $3x^5$  and  $2x^4$  is

- [A]  $6x^9$     [B]  $5x^{20}$     [C]  $5x^9$     [D]  $6x^{20}$

641. 010823a, P.I. 8.G.3  
Two angles are complementary. The measure of one angle is  $15^\circ$  more than twice the other. What is the measure of the *smaller* angle?

- [A]  $25^\circ$     [B]  $65^\circ$     [C]  $35^\circ$     [D]  $55^\circ$

642. 010505a, P.I. G.G.45  
The perimeter of  $\triangle A'B'C'$ , the image of  $\triangle ABC$ , is twice as large as the perimeter of  $\triangle ABC$ . What type of transformation has taken place?

- [A] rotation    [B] dilation  
[C] reflection    [D] translation

643. 089935a, P.I. A.A.7  
Two health clubs offer different membership plans. The graph below represents the total cost of belonging to Club A and Club B for one year.

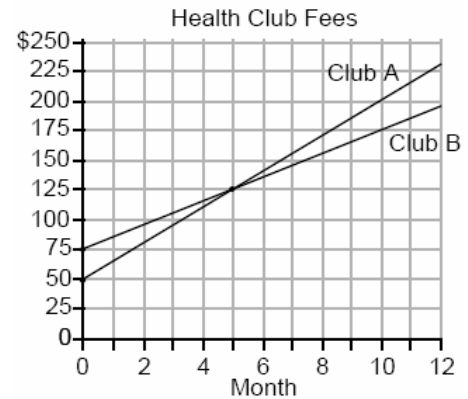

- a If the yearly cost includes a membership fee plus a monthly charge, what is the membership fee for Club A?  
b (1) What is the number of the month when the total cost is the same for both clubs?  
(2) What is the total cost for Club A when both plans are the same?  
c What is the monthly charge for Club B?

644. 080608a, P.I. 6.S.5  
The accompanying graph shows the high temperatures in Elmira, New York, for a 5-day period in January.

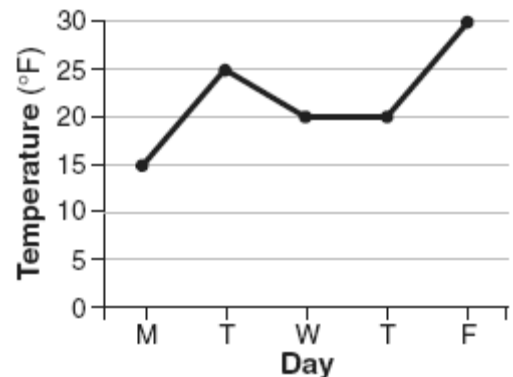

- Which statement describes the data?  
[A] mean = mode    [B] median = mean  
[C] median = mode    [D] mean < mode

645. 060034a, P.I. A.2.S.12  
Paul orders a pizza. Chef Carl randomly chooses two different toppings to put on the pizza from the following: pepperoni, onion, sausage, mushrooms, and anchovies. If Paul will not eat pizza with mushrooms, determine the probability that Paul will *not* eat the pizza Chef Carl has made.

646. 060325a  
On the accompanying diagram of  $\triangle ABC$ , use a compass and a straightedge to construct a median from  $A$  to  $\overline{BC}$ .

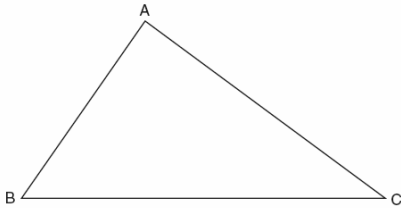

647. 010719a, P.I. A.A.22  
What is the value of  $x$  in the equation  
$$\frac{x}{2} + \frac{x}{6} = 2?$$
  
[A] 8      [B] 12      [C] 3      [D]  $\frac{1}{4}$

648. 010737a, P.I. A.A.6  
The Eye Surgery Institute just purchased a new laser machine for \$500,000 to use during eye surgery. The Institute must pay the inventor \$550 each time the machine is used. If the Institute charges \$2,000 for each laser surgery, what is the *minimum* number of surgeries that must be performed in order for the Institute to make a profit?

649. 080418a, P.I. G.G.54  
What is the image of point  $(-3, -1)$  under a reflection in the origin?  
[A]  $(-3, 1)$       [B]  $(-1, -3)$   
[C]  $(3, 1)$       [D]  $(1, 3)$

650. 010327a, P.I. A.A.7  
Arielle has a collection of grasshoppers and crickets. She has 561 insects in all. The number of grasshoppers is twice the number of crickets. Find the number of *each* type of insect that she has.

651. 080731a, P.I. A.A.22  
Solve for  $x$ :  $5(x - 2) = 2(10 + x)$

652. 010401a, P.I. A.A.22  
If  $2(x + 3) = x + 10$ , then  $x$  equals  
[A] 14      [B] 5      [C] 4      [D] 7

653. 060717a, P.I. G.G.26  
What is the converse of the statement "If the Sun rises in the east, then it sets in the west"?  
[A] If the Sun does not rise in the east, then it does not set in the west.  
[B] If the Sun sets in the west, then it rises in the east.  
[C] If the Sun rises in the west, then it sets in the east.  
[D] If the Sun does not set in the west, then it does not rise in the east.

654. 089913a, P.I. A.A.6  
If 6 and  $x$  have the same mean (average) as 2, 4, and 24, what is the value of  $x$ ?  
[A] 10      [B] 5      [C] 14      [D] 36

655. 060016a, P.I. A.N.8  
How many different five-digit numbers can be formed from the digits 1, 2, 3, 4, and 5 if each digit is used only once?  
[A] 120      [B] 60      [C] 24      [D] 20

656. 010332a, P.I. A.A.7  
Alexandra purchases two doughnuts and three cookies at a doughnut shop and is charged \$3.30. Briana purchases five doughnuts and two cookies at the same shop for \$4.95. All the doughnuts have the same price and all the cookies have the same price. Find the cost of one doughnut and find the cost of one cookie.

657. 010227a, P.I. A.G.2  
In the accompanying diagram, a rectangular container with the dimensions 10 inches by 15 inches by 20 inches is to be filled with water, using a cylindrical cup whose radius is 2 inches and whose height is 5 inches. What is the maximum number of full cups of water that can be placed into the container without the water overflowing the container?

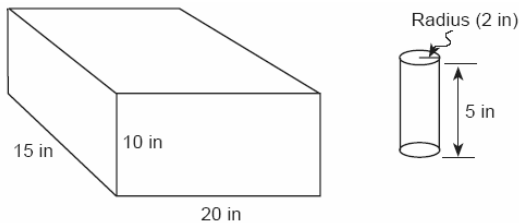

658. 010127a, P.I. G.G.22  
Steve has a treasure map, represented in the accompanying diagram, that shows two trees 8 feet apart and a straight fence connecting them. The map states that treasure is buried 3 feet from the fence and equidistant from the two trees.

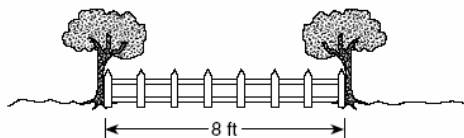

- a Sketch a diagram to show all the places where the treasure could be buried. Clearly indicate in your diagram where the treasure could be buried.
- b What is the distance between the treasure and one of the trees?

659. 080113a, P.I. 7.N.11  
If  $n$  represents an odd number, which computation results in an answer that is an even number?

- [A]  $3 \times n + 1$                       [B]  $2 \times n - 1$   
[C]  $3 \times n - 2$                       [D]  $2 \times n + 1$

660. 080133a, P.I. A.A.44  
A ship on the ocean surface detects a sunken ship on the ocean floor at an angle of depression of  $50^\circ$ . The distance between the ship on the surface and the sunken ship on the ocean floor is 200 meters. If the ocean floor is level in this area, how far above the ocean floor, to the nearest meter, is the ship on the surface?

661. 010535a  
Construct a stem-and-leaf plot listing the scores below in order from lowest to highest.  
15, 25, 28, 32, 39, 40, 43, 26, 50, 75, 65, 19,  
55, 72, 50

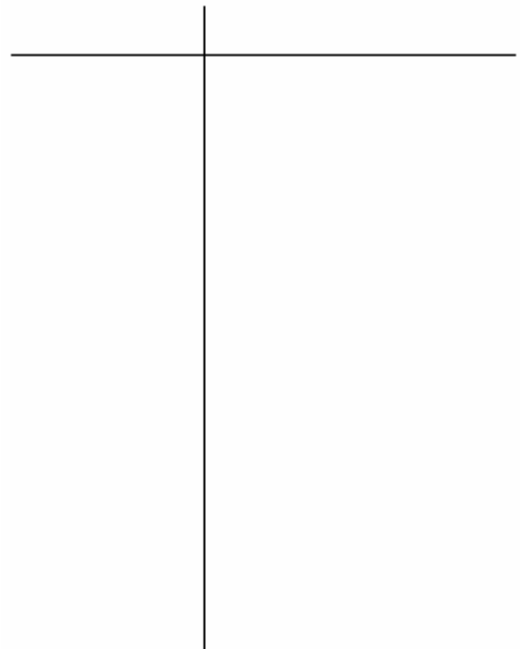

662. 010033a, P.I. A.A.7  
A group of 148 people is spending five days at a summer camp. The cook ordered 12 pounds of food for each adult and 9 pounds of food for each child. A total of 1,410 pounds of food was ordered.
- a* Write an equation or a system of equations that describes the above situation and define your variables.
- b* Using your work from part *a*, find:
- (1) the total number of adults in the group
  - (2) the total number of children in the group

663. 060006a, P.I. G.G.26  
What is the inverse of the statement "If it is sunny, I will play baseball"?
- [A] If I do not play baseball, then it is not sunny.
- [B] If I play baseball, then it is sunny.
- [C] I will play baseball if and only if it is sunny.
- [D] If it is not sunny, I will not play baseball.

664. 060701a  
Which letter has both point and line symmetry?
- [A] H      [B] T      [C] C      [D] Z

665. 080634a, P.I. G.G.23  
Dan is sketching a map of the location of his house and his friend Matthew's house on a set of coordinate axes. Dan locates his house at point  $D(0,0)$  and locates Matthew's house, which is 6 miles east of Dan's house, at point  $M(6,0)$ . On the accompanying set of coordinate axes, graph the locus of points equidistant from the two houses. Then write the equation of the locus.

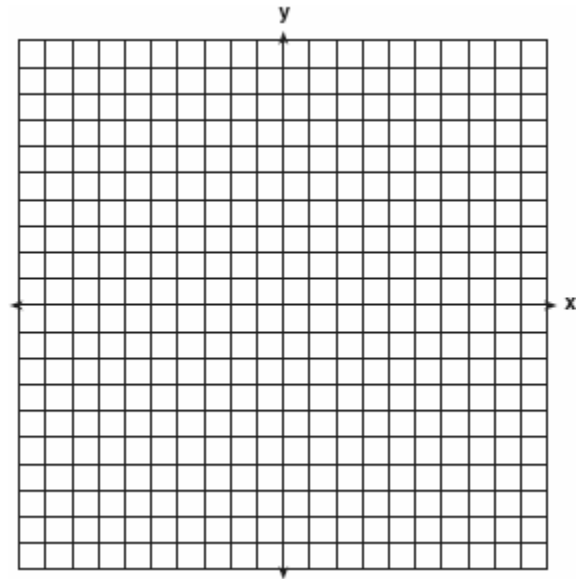

666. 060223a, P.I. A.A.26  
If the instructions for cooking a turkey state "Roast turkey at  $325^\circ$  for 20 minutes per pound," how many hours will it take to roast a 20-pound turkey at  $325^\circ$ ?

667. 010603a, P.I. A.G.1

The lengths of the sides of home plate in a baseball field are represented by the expressions in the accompanying figure.

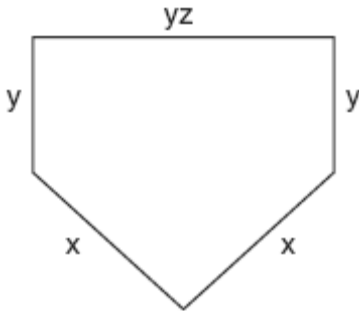

Which expression represents the perimeter of the figure?

- [A]  $x^2 + y^3z$                       [B]  $2x + 2y + yz$   
[C]  $5xyz$                               [D]  $2x + 3yz$

668. 060510a, P.I. G.G.31

Tina wants to sew a piece of fabric into a scarf in the shape of an isosceles triangle, as shown in the accompanying diagram.

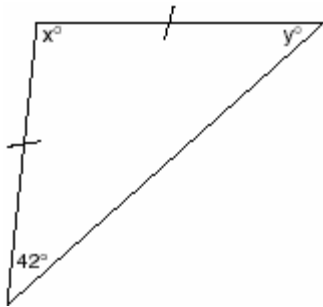

What are the values of  $x$  and  $y$ ?

- [A]  $x = 90$  and  $y = 48$   
[B]  $x = 69$  and  $y = 69$   
[C]  $x = 42$  and  $y = 96$   
[D]  $x = 96$  and  $y = 42$

669. 010007a, P.I. G.G.54

When the point  $(2, -5)$  is reflected in the  $x$ -axis, what are the coordinates of its image?

- [A]  $(-2, 5)$                               [B]  $(-5, 2)$   
[C]  $(2, 5)$                                 [D]  $(5, 2)$

670. 060710a, P.I. A.A.45

If the length of a rectangular television screen is 20 inches and its height is 15 inches, what is the length of its diagonal, in inches?

- [A] 5    [B] 35    [C] 13.2    [D] 25

671. 060519a, P.I. A.A.6

If  $-2x + 3 = 7$  and  $3x + 1 = 5 + y$ , the value of  $y$  is

- [A] 0    [B] 1    [C]  $-10$     [D] 10

672. 080604a, P.I. A.S.20

The faces of a cube are numbered from 1 to 6. What is the probability of *not* rolling a 5 on a single toss of this cube?

- [A]  $\frac{5}{6}$     [B]  $\frac{4}{5}$     [C]  $\frac{1}{5}$     [D]  $\frac{1}{6}$

673. 060114a, P.I. A2.S.11

If there are four teams in a league, how many games will have to be played so that each team plays every other team once?

- [A] 8    [B] 6    [C] 16    [D] 3

674. 080722a, P.I. A.A.23

Which equation is equivalent to  $3x + 4y = 15$ ?

- [A]  $y = 3x - 15$                       [B]  $y = \frac{15 - 3x}{4}$   
[C]  $y = \frac{3x - 15}{4}$                               [D]  $y = 15 - 3x$

675. 060513a, P.I. A.A.22

If  $7x + 2a = 3x + 5a$ , then  $x$  is equivalent to

- [A]  $\frac{3a}{10}$     [B]  $\frac{3a}{4}$     [C]  $\frac{7a}{4}$     [D]  $\frac{7a}{10}$

676. 010301a, P.I. A.S.6

The accompanying diagram shows a box-and-whisker plot of student test scores on last year's Mathematics A midterm examination.

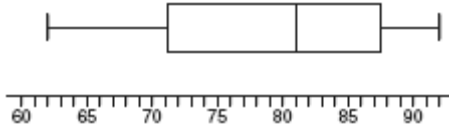

What is the median score?

- [A] 71    [B] 81    [C] 62    [D] 92

677. 010109a, P.I. A.A.14

If  $x \neq 0$ , the expression  $\frac{x^2 + 2x}{x}$  is equivalent to

- [A] 4    [B]  $x + 2$     [C]  $3x$     [D] 2

678. 080509a, P.I. A.A.1

The sum of Scott's age and Greg's age is 33 years. If Greg's age is represented by  $g$ , Scott's age is represented by

- [A]  $33g$     [B]  $33 - g$   
[C]  $g - 33$     [D]  $g + 33$

679. 010223a, P.I. G.G.30

Vertex angle  $A$  of isosceles triangle  $ABC$  measures  $20^\circ$  more than three times  $m\angle B$ . Find  $m\angle C$ .

680. 010029a

On the set of axes provided below, sketch a circle with a radius of 3 and center at  $(2,1)$  and also sketch the graph of the line  $2x + y = 8$ .

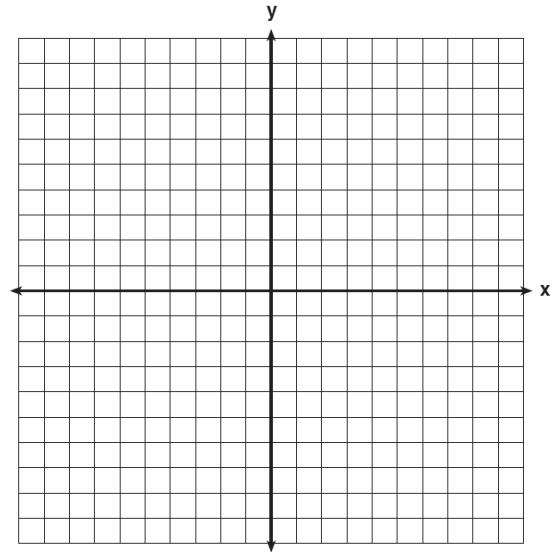

*b* What is the total number of points of intersection of the two graphs?

681. 080007a

The volume of a cube is 64 cubic inches. Its total surface area, in square inches, is

- [A] 48    [B] 96    [C] 16    [D] 576



682. 010325a, P.I. 7.S.6  
Mr. Smith's class voted on their favorite ice cream flavors, and the results are shown in the accompanying diagram. If there are 20 students in Mr. Smith's class, how many students chose coffee ice cream as their favorite flavor?

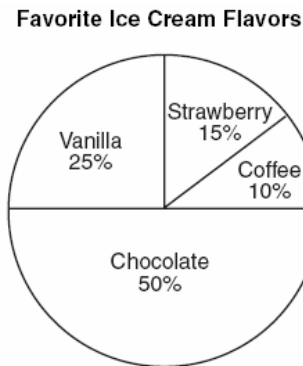

683. 080420a, P.I. 7.A.10  
Which linear equation represents the data in the accompanying table?

$c$	$d$
0	20.00
1	21.50
2	23.00
3	24.50

- [A]  $d = 20.00c + 1.50$       [B]  $d = 21.50c$   
 [C]  $d = 1.50c + 20.00$       [D]  $d = 1.50c$
684. 080516a, P.I. 7.N.3  
Which numbers are arranged from smallest to largest?

- [A]  $\sqrt{9.1}, \pi, 3.14, \frac{22}{7}$   
 [B]  $\sqrt{9.1}, 3.14, \frac{22}{7}, \pi$   
 [C]  $\sqrt{9.1}, 3.14, \pi, \frac{22}{7}$   
 [D]  $3.14, \frac{22}{7}, \pi, \sqrt{9.1}$

685. 080032a, P.I. G.G.69  
Ashanti is surveying for a new parking lot shaped like a parallelogram. She knows that three of the vertices of parallelogram  $ABCD$  are  $A(0,0)$ ,  $B(5,2)$ , and  $C(6,5)$ . Find the coordinates of point  $D$  and sketch parallelogram  $ABCD$  on the accompanying set of axes. Justify mathematically that the figure you have drawn is a parallelogram.

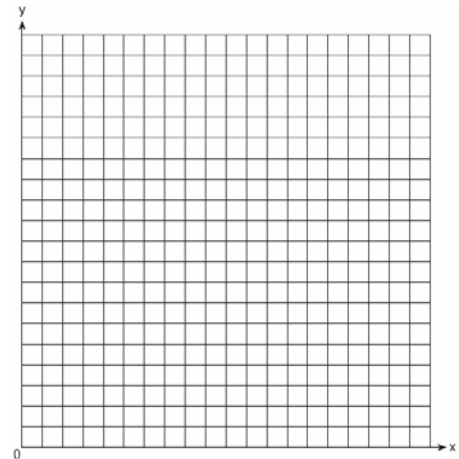

686. 080230a  
On the accompanying grid, graph a circle whose center is at  $(0,0)$  and whose radius is 5. Determine if the point  $(5,-2)$  lies on the circle.

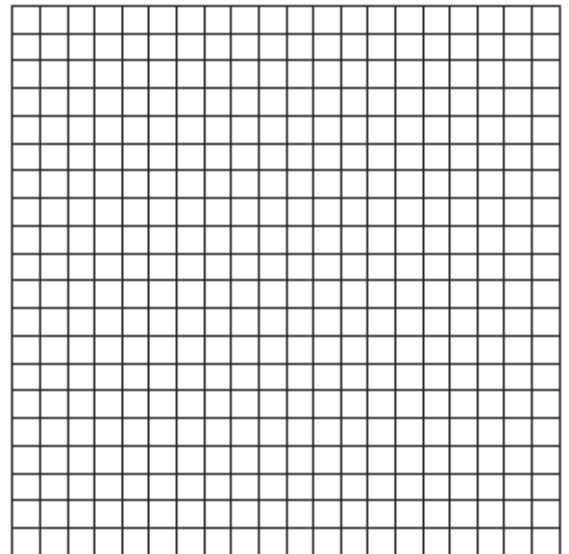

687. 060716a, P.I. A.A.10  
Which ordered pair satisfies the system of equations below?

$$3x - y = 8$$

$$x + y = 2$$

- [A] (2.5, -0.5)      [B] (2.5, 0.5)  
[C] (3, -1)          [D] (5, -3)
688. 060422a, P.I. 7.S.6  
The accompanying circle graph shows how the Marino family spends its income each month.

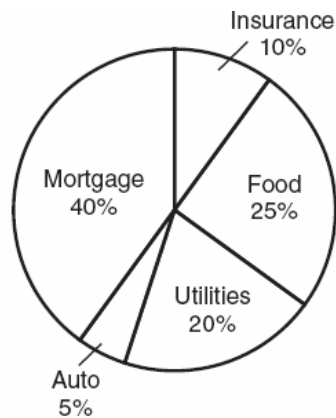

What is the measure, in degrees, of the central angle that represents the percentage of income spent on food?

- [A] 90      [B] 25      [C] 360      [D] 50
689. 010706a, P.I. G.G.25  
The statement " $x \geq 4$  and  $2x - 4 < 6$ " is true when  $x$  is equal to
- [A] 5      [B] 1      [C] 4      [D] 10
690. 060709a, P.I. A.M.2  
Andy is 6 feet tall. If 1 inch equals 2.54 centimeters, how tall is Andy, to the *nearest centimeter*?
- [A] 183      [B] 15      [C] 30      [D] 213

691. 060220a  
The accompanying diagram is an example of which type of graph?

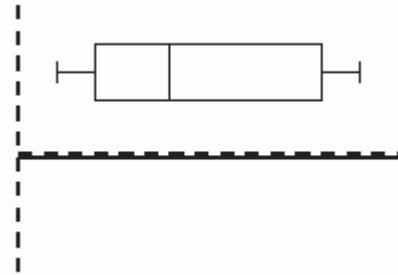

- [A] stem-and-leaf plot      [B] histogram  
[C] box-and-whisker plot      [D] bar graph
692. 080533a, P.I. A2.A.7  
Factor completely:  $5n^2 - 80$
693. 060509a, P.I. 6.S.5  
Jorge made the accompanying stem-and-leaf plot of the weights, in pounds, of each member of the wrestling team he was coaching.

Stem	Leaf
10	9
11	
12	3 8
13	2 4 4 6 8
14	1 3 5 5 9
15	2 3 7 7 9
16	1 3 7 8 8 8 9
17	3 8

Key: 16 | 1 = 161

What is the mode of the weights?  
[A] 145      [B] 152      [C] 168      [D] 150

694. 080503a, P.I. A.N.6  
The value of  $\frac{7!}{3!}$  is
- [A] 24      [B] 4      [C] 840      [D] 7

695. 010410a, P.I. G.G.45  
The accompanying diagram shows two similar triangles.

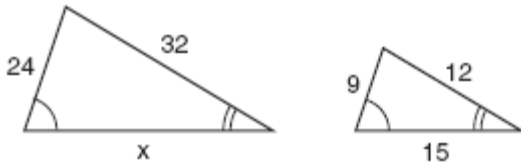

Which proportion could be used to solve for  $x$ ?

- [A]  $\frac{x}{24} = \frac{9}{15}$       [B]  $\frac{32}{12} = \frac{15}{x}$   
 [C]  $\frac{32}{x} = \frac{12}{15}$       [D]  $\frac{24}{9} = \frac{15}{x}$
696. 080209a, P.I. A.A.13  
When  $-2x^2 + 4x + 2$  is subtracted from  $x^2 + 6x - 4$ , the result is
- [A]  $-x^2 + 10x - 2$       [B]  $2x^2 - 2x - 6$   
 [C]  $3x^2 + 2x - 6$       [D]  $-3x^2 - 2x + 6$

697. 069935a, P.I. A.A.11  
Solve the following system of equations algebraically or graphically for  $x$  and  $y$ :

$$y = x^2 + 2x - 1$$

$$y = 3x + 5$$

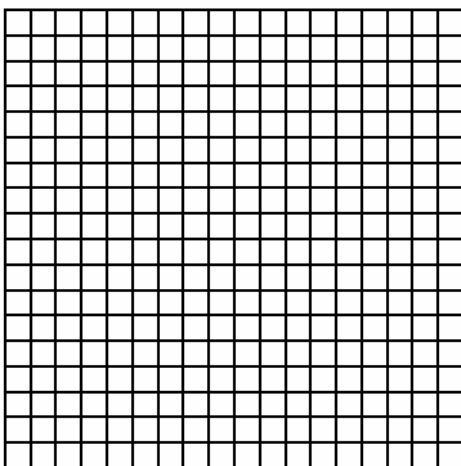

698. 060018a, P.I. A.A.11  
The graphs of the equations  $y = x^2 + 4x - 1$  and  $y + 3 = x$  are drawn on the same set of axes. At which point do the graphs intersect?

- [A] (1, 4)      [B] (-2, -5)  
 [C] (-2, 1)      [D] (1, -2)

699. 060728a, P.I. A2.S.9  
Max goes through the cafeteria line and counts seven different meals and three different desserts that he can choose. Which expression can be used to determine how many different ways Max can choose a meal and a dessert?

- [A]  ${}_7P_3$       [B]  $7! \cdot 3!$   
 [C]  ${}_7C_3$       [D]  $7 \cdot 3$

700. 010639a, P.I. 8.A.12  
In the accompanying diagram,  $\overleftrightarrow{CD} \parallel \overleftrightarrow{EF}$ ,  $\overleftrightarrow{AB}$  is a transversal,  $m\angle DGH = 2x$ , and  $m\angle FHB = 5x - 51$ . Find the measure, in degrees, of  $\angle BHE$ .

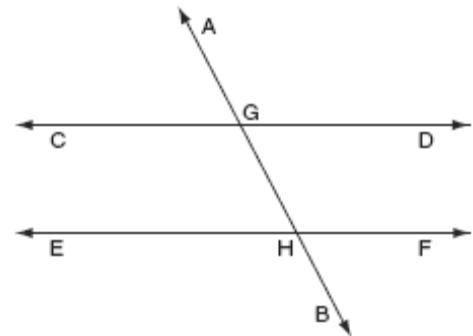

701. 010329a, P.I. A.A.7

Currently, Tyrone has \$60 and his sister has \$135. Both get an allowance of \$5 each week. Tyrone decides to save his entire allowance, but his sister spends all of hers each week plus an additional \$10 each week. After how many weeks will they each have the same amount of money? [The use of the grid is optional.]

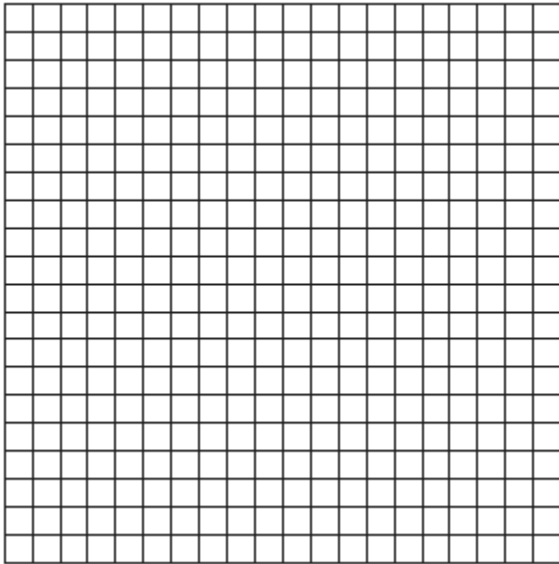

702. 060739a, P.I. G.G.54

Carson is a decorator. He often sketches his room designs on the coordinate plane. He has graphed a square table on his grid so that its corners are at the coordinates  $A(2,6)$ ,  $B(7,8)$ ,  $C(9,3)$ , and  $D(4,1)$ . To graph a second identical table, he reflects  $ABCD$  over the  $y$ -axis. On the accompanying set of coordinate axes, sketch and label  $ABCD$  and its image  $A'B'C'D'$ , which show the locations of the two tables. Then find the number of square units in the area of  $ABCD$ .

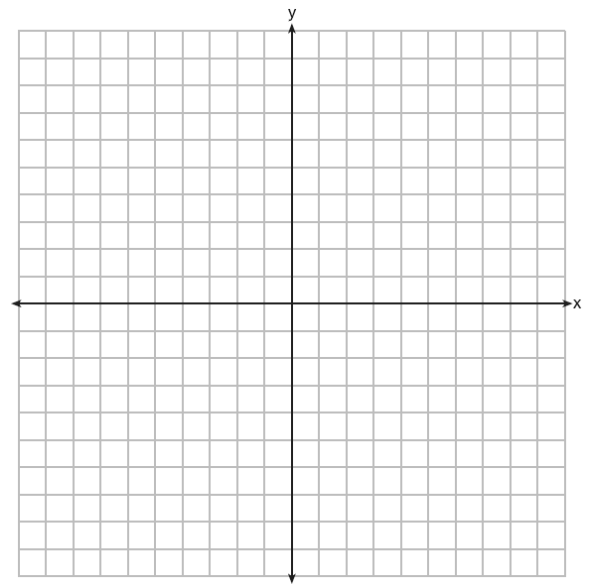

703. 010207a, P.I. A.N.1

Which expression must be added to  $3x - 7$  to equal 0?

[A]  $-3x + 7$

[B] 0

[C]  $-3x - 7$

[D]  $3x + 7$

704. 080028a, P.I. G.G.54, G.G.58

The coordinates of the endpoints of  $\overline{AB}$  are  $A(2,6)$  and  $B(4,2)$ . Is the image  $\overline{A''B''}$  the same if it is reflected in the  $x$ -axis, then dilated by  $\frac{1}{2}$  as the image is if it is dilated by  $\frac{1}{2}$ , then reflected in the  $x$ -axis? Justify your answer.

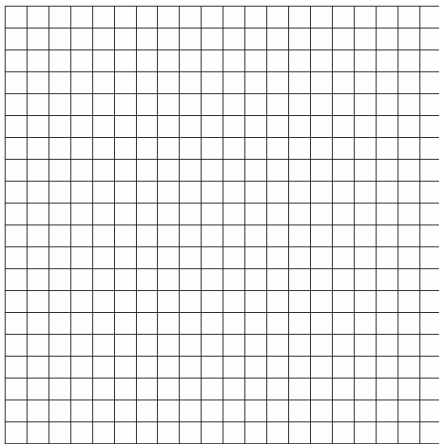

705. 080018a, P.I. G.G.33

If two sides of a triangle are 1 and 3, the third side may be

- [A] 3      [B] 5      [C] 4      [D] 2

706. 010432a, P.I. A.A.6

TOP Electronics is a small business with five employees. The mean (average) weekly salary for the five employees is \$360. If the weekly salaries of four of the employees are \$340, \$340, \$345, and \$425, what is the salary of the fifth employee?

707. 080703a, P.I. A.G.4

Super Painters charges \$1.00 per square foot plus an additional fee of \$25.00 to paint a living room. If  $x$  represents the area of the walls of Francesca's living room, in square feet, and  $y$  represents the cost, in dollars, which graph best represents the cost of painting her living room?

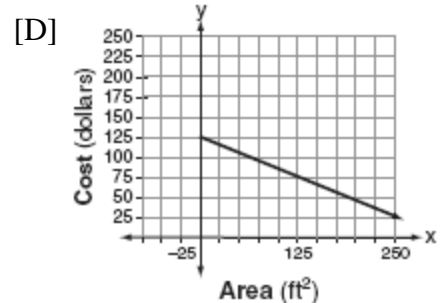
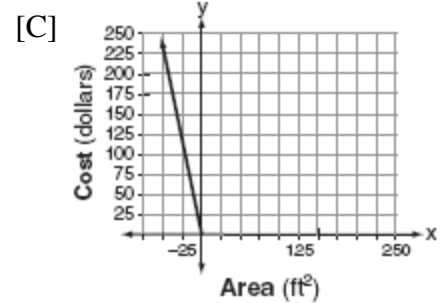
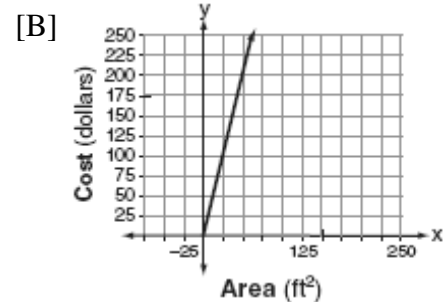
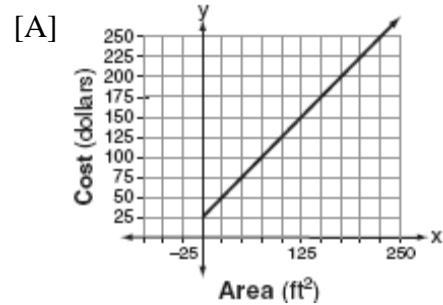

708. 010208a

What is the greatest possible number of points of intersection of a triangle and a circle?

- [A] 3      [B] 6      [C] 2      [D] 4

709. 060103a

If the length of a rectangular prism is doubled, its width is tripled, and its height remains the same, what is the volume of the new rectangular prism?

- [A] nine times the original volume
- [B] six times the original volume
- [C] double the original volume
- [D] triple the original volume

710. 089905a, P.I. A.G.1

The Pentagon building in Washington, D.C., is shaped like a regular pentagon. If the length of one side of the Pentagon is represented by  $n + 2$ , its perimeter would be represented by

- [A]  $10n$
- [B]  $5n + 10$
- [C]  $5n + 2$
- [D]  $n + 10$

711. 060314a, P.I. 7.N.11

If the expression  $3 - 4^2 + \frac{6}{2}$  is evaluated, what would be done *last*?

- [A] dividing
- [B] squaring
- [C] subtracting
- [D] adding

712. 060505a, P.I. A.A.26

A cake recipe calls for 1.5 cups of milk and 3 cups of flour. Seth made a mistake and used 5 cups of flour. How many cups of milk should he use to keep the proportions correct?

- [A] 2
- [B] 1.75
- [C] 2.25
- [D] 2.5

713. 080002a, P.I. A.A.1

A hockey team played  $n$  games, losing four of them and winning the rest. The ratio of games won to games lost is

- [A]  $\frac{n-4}{4}$
- [B]  $\frac{4}{n-4}$
- [C]  $\frac{4}{n}$
- [D]  $\frac{n}{4}$

714. 080714a, P.I. 6.S.5

The accompanying stem-and-leaf plot represents Ben's test scores this year.

6		5	8				
7		2	3	3	3	3	9
8		1	3	3	6	7	
9		6	9	9			

Key: 7 | 2 = 72

What is the median score for this set of data?

- [A] 81
- [B] 79
- [C] 73
- [D] 80

715. 010030a

The volume of a rectangular pool is 1,080 cubic meters. Its length, width, and depth are in the ratio 10:4:1. Find the number of meters in each of the three dimensions of the pool.

716. 069928a, P.I. A.A.6

A swimmer plans to swim at least 100 laps during a 6-day period. During this period, the swimmer will increase the number of laps completed each day by one lap. What is the *least* number of laps the swimmer must complete on the first day?

717. 089928a, P.I. G.G.25

Bob and Ray are describing the same number. Bob says, "The number is a positive even integer less than or equal to 20." Ray says, "The number is divisible by 4." If Bob's statement is true and Ray's statement is false, what are all the possible numbers?

718. 010709a, P.I. A.S.20

Seth tossed a fair coin five times and got five heads. The probability that the next toss will be a tail is

- [A]  $\frac{5}{6}$
- [B]  $\frac{1}{6}$
- [C]  $\frac{1}{2}$
- [D] 0

719. 010735a, P.I. A.A.44  
From a point on level ground 25 feet from the base of a tower, the angle of elevation to the top of the tower is  $78^\circ$ , as shown in the accompanying diagram. Find the height of the tower, to the nearest tenth of a foot.

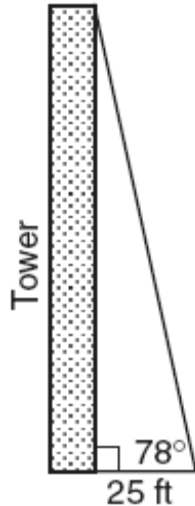

720. 089916a, P.I. A.A.7  
At a concert, \$720 was collected for hot dogs, hamburgers, and soft drinks. All three items sold for \$1.00 each. Twice as many hot dogs were sold as hamburgers. Three times as many soft drinks were sold as hamburgers. The number of soft drinks sold was  
[A] 240 [B] 360 [C] 480 [D] 120
721. 010517a, P.I. A.A.23  
Sean knows the length of the base,  $b$ , and the area,  $A$ , of a triangular window in his bedroom. Which formula could he use to find the height,  $h$ , of this window?  
[A]  $h = (2A)(b)$  [B]  $h = 2A - b$   
[C]  $h = \frac{A}{2b}$  [D]  $h = \frac{2A}{b}$

722. 060326a, P.I. A.A.7  
Seth has one less than twice the number of compact discs (CDs) that Jason has. Raoul has 53 more CDs than Jason has. If Seth gives Jason 25 CDs, Seth and Jason will have the same number of CDs. How many CDs did each of the three boys have to begin with?

723. 010435a, P.I. A.N.8  
In Jackson County, Wyoming, license plates are made with two letters (A through Z) followed by three digits (0 through 9). The plates are made according to the following restrictions:  
o the first letter must be  $J$  or  $W$ , and the second letter can be any of the 26 letters in the alphabet  
o no digit can be repeated  
How many different license plates can be made with these restrictions?

724. 069932a, P.I. A2.S.12  
A bookshelf contains six mysteries and three biographies. Two books are selected at random without replacement.  
 $a$  What is the probability that both books are mysteries?  
 $b$  What is the probability that one book is a mystery and the other is a biography?

725. 010725a, P.I. G.G.58  
The image of point  $A$  after a dilation of 3 is  $(6,15)$ . What was the original location of point  $A$ ?  
[A]  $(9,18)$  [B]  $(18,45)$   
[C]  $(2,5)$  [D]  $(3,12)$

726. 060216a, P.I. G.G.60

In the accompanying diagram,  $\triangle ABC$  is similar to but not congruent to  $\triangle A'B'C'$ . Which transformation is represented by  $\triangle A'B'C'$ ?

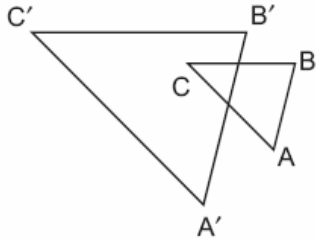

- [A] translation                      [B] reflection  
[C] rotation                         [D] dilation

727. 010817a, P.I. A.A.12

The expression  $\frac{4x^2y^3}{2xy^4}$  is equivalent to

- [A]  $\frac{2y}{x}$     [B]  $2xy$     [C]  $-2xy$     [D]  $\frac{2x}{y}$

728. 010527a, P.I. G.G.22

How many points are equidistant from two parallel lines and also equidistant from two points on one of the lines?

- [A] 1            [B] 2            [C] 3            [D] 4

729. 060705a, P.I. A.S.20

A six-sided number cube has faces with the numbers 1 through 6 marked on it. What is the probability that a number less than 3 will occur on one toss of the number cube?

- [A]  $\frac{4}{6}$             [B]  $\frac{3}{6}$             [C]  $\frac{1}{6}$             [D]  $\frac{2}{6}$

730. 010321a, P.I. A.S.19

If Laquisha can enter school by any one of three doors and the school has two staircases to the second floor, in how many different ways can Laquisha reach a room on the second floor? Justify your answer by drawing a tree diagram or listing a sample space.

731. 080438a

In the accompanying diagram, right triangle  $ABC$  is inscribed in circle  $O$ , diameter  $AB = 26$ , and  $CB = 10$ . Find, to the nearest square unit, the area of the shaded region.

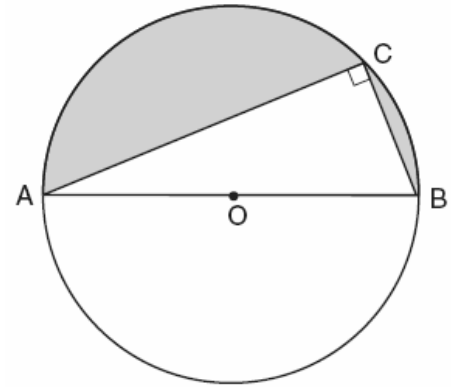

732. 010313a, P.I. 8.G.3

If the measure of an angle is represented by  $2x$ , which expression represents the measure of its complement?

- [A]  $88x$                                       [B]  $180 - 2x$   
[C]  $90 + 2x$                                 [D]  $90 - 2x$

733. 010415a, P.I. G.G.26

Which statement is the converse of "If the sum of two angles is  $180^\circ$ , then the angles are supplementary"?

- [A] If the sum of two angles is not  $180^\circ$ , then the angles are not supplementary.  
[B] If two angles are not supplementary, then their sum is not  $180^\circ$ .  
[C] If the sum of two angles is not  $180^\circ$ , then the angles are supplementary.  
[D] If two angles are supplementary, then their sum is  $180^\circ$ .



734. 080026a  
John, Dan, Karen, and Beth went to a costume ball. They chose to go as Anthony and Cleopatra, and Romeo and Juliet. John got the costumes for Romeo and Cleopatra, but not his own costume. Dan saw the costumes for Juliet and himself. Karen went as Anthony. Beth drove two of her friends, who were dressed as Anthony and Cleopatra, to the ball. What costume did John wear?

735. 060521a, P.I. A.A.34  
If point  $(-1,0)$  is on the line whose equation is  $y = 2x + b$ , what is the value of  $b$ ?

- [A] 1      [B] 0      [C] 2      [D] 3

736. 060406a, P.I. A.A.6  
Parking charges at Superior Parking Garage are \$5.00 for the first hour and \$1.50 for each additional 30 minutes. If Margo has \$12.50, what is the maximum amount of time she will be able to park her car at the garage?

- [A] 6 hours                      [B]  $3\frac{1}{2}$  hours  
[C]  $2\frac{1}{2}$  hours                      [D]  $6\frac{1}{2}$  hours

737. 060211a, P.I. 7.N.2  
Which is an irrational number?

- [A]  $\sqrt{9}$       [B]  $-\frac{1}{3}$       [C] 0      [D]  $\pi$

738. 010403a, P.I. 7.N.13  
On February 18, from 9 a.m. until 2 p.m., the temperature rose from  $-14^\circ\text{F}$  to  $36^\circ\text{F}$ . What was the total increase in temperature during this time period?

- [A]  $36^\circ$       [B]  $50^\circ$       [C]  $22^\circ$       [D]  $32^\circ$

739. 060122a, P.I. 8.G.5  
In the accompanying diagram, parallel lines  $\overline{AB}$  and  $\overline{CD}$  are intersected by transversal  $\overline{EF}$  at points  $X$  and  $Y$ , and  $m\angle FYD = 123$ . Find  $m\angle AXY$ .

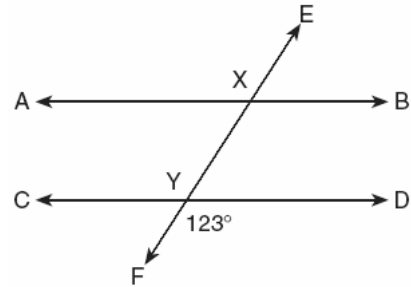

740. 010822a, P.I. A.A.15  
For which value of  $x$  is the expression  $\frac{6-x}{x+2}$  undefined?

- [A] -2      [B] 6      [C] 0      [D] 2

741. 080108a, P.I. A.G.1  
What is the approximate circumference of a circle with radius 3?

- [A] 9.42                      [B] 7.07  
[C] 18.85                      [D] 28.27

742. 010609a, P.I. 7.N.5  
The size of a certain type of molecule is 0.00009078 inch. If this number is expressed as  $9.078 \times 10^n$ , what is the value of  $n$ ?

- [A] -5      [B] 8      [C] -8      [D] 5

743. 010021a

The midpoint  $M$  of line segment  $AB$  has coordinates  $(-3,4)$ . If point  $A$  is the origin,  $(0,0)$ , what are the coordinates of point  $B$ ?  
[The use of the accompanying grid is optional.]

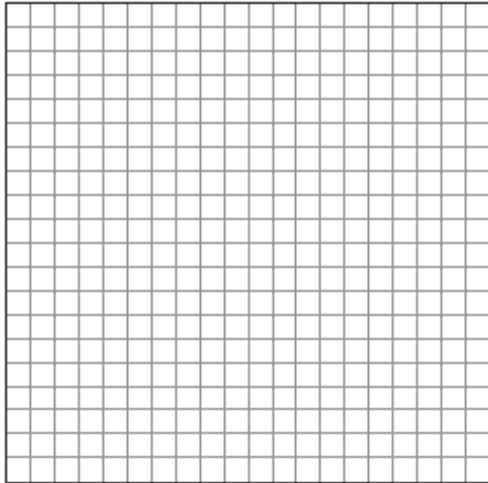

744. 080132a, P.I. A.A.7

The ninth graders at a high school are raising money by selling T-shirts and baseball caps. The number of T-shirts sold was three times the number of caps. The profit they received for each T-shirt sold was \$5.00, and the profit on each cap was \$2.50. If the students made a total profit of \$210, how many T-shirts *and* how many caps were sold?

745. 080514a, P.I. A.N.1

What is the identity element for  $\clubsuit$  in the accompanying table?

$\clubsuit$	$r$	$s$	$t$	$u$
$r$	$t$	$r$	$u$	$s$
$s$	$r$	$s$	$t$	$u$
$t$	$u$	$t$	$s$	$r$
$u$	$s$	$u$	$r$	$t$

- [A]  $u$     [B]  $s$     [C]  $t$     [D]  $r$

746. 060234a, P.I. A2.S.12

Alexi's wallet contains four \$1 bills, three \$5 bills, and one \$10 bill. If Alexi randomly removes two bills without replacement, determine whether the probability that the bills will total \$15 is greater than the probability that the bills will total \$2.

747. 080211a, P.I. G.G.61

If  $x = -2$  and  $y = -1$ , which point on the accompanying set of axes represents the translation  $(x, y) \rightarrow (x + 2, y - 3)$ ?

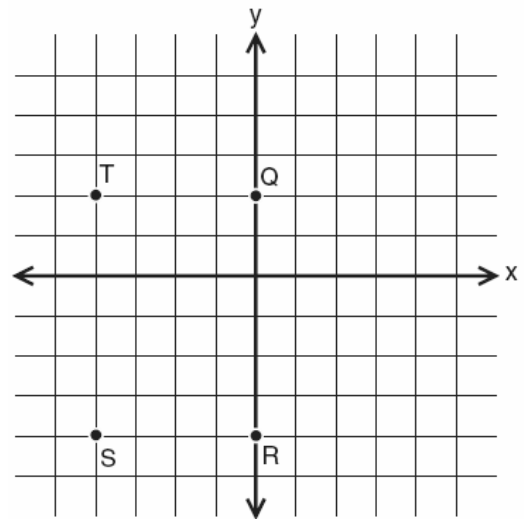

- [A]  $Q$     [B]  $S$     [C]  $T$     [D]  $R$

748. 060729a

If the product of  $x$  and  $\frac{1}{m}$  is  $-1$ ,  $m \neq 0$ , then  $x$  is equivalent to

- [A]  $m$     [B]  $1-m$     [C]  $-m$     [D]  $-\frac{1}{m}$

749. 010106a, P.I. A2.S.13  
At a school fair, the spinner represented in the accompanying diagram is spun twice.

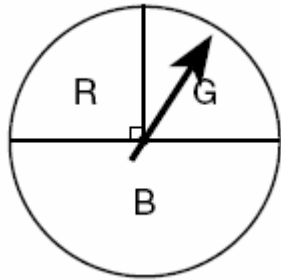

What is the probability that it will land in section *G* the first time and then in section *B* the second time?

- [A]  $\frac{1}{8}$     [B]  $\frac{1}{16}$     [C]  $\frac{1}{4}$     [D]  $\frac{1}{2}$
750. 060437a, P.I. A.G.1  
Express both the perimeter and the area of the rectangle shown in the accompanying diagram as polynomials in simplest form.

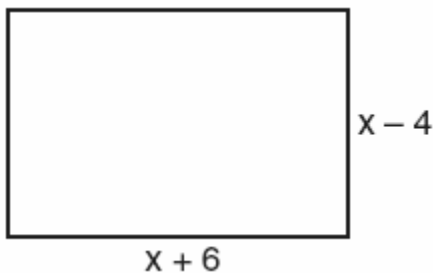

751. 010721a, P.I. G.G.39  
A set of five quadrilaterals consists of a square, a rhombus, a rectangle, an isosceles trapezoid, and a parallelogram. Lu selects one of these figures at random. What is the probability that both pairs of the figure's opposite sides are parallel?
- [A]  $\frac{4}{5}$     [B]  $\frac{3}{4}$     [C] 1    [D]  $\frac{2}{5}$

752. 060112a, P.I. G.G.26  
Which statement is logically equivalent to "If I eat, then I live"?
- [A] If I do not live, then I do not eat.  
[B] I live if and only if I eat.  
[C] If I eat, then I do not live.  
[D] If I live, then I eat.

753. 060639a, P.I. A.A.44  
A person measures the angle of depression from the top of a wall to a point on the ground. The point is located on level ground 62 feet from the base of the wall and the angle of depression is  $52^\circ$ . How high is the wall, to the nearest tenth of a foot?

754. 060538a, P.I. 7.S.2  
In a class of 24 students, 10 have brown hair, 8 have black hair, 4 have blond hair, and 2 have red hair. On the accompanying diagram, construct a circle graph to show the students' hair color.

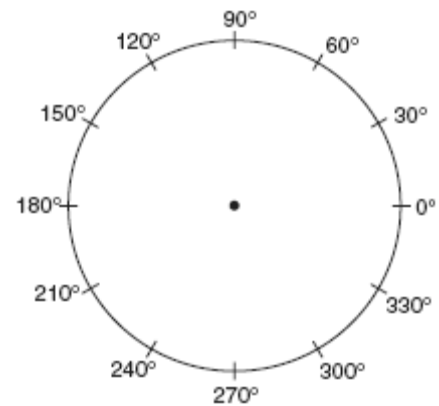

755. 060512a, P.I. A.N.3  
The expression  $\sqrt{50} + \sqrt{32}$  is equivalent to
- [A]  $\sqrt{82}$     [B]  $9\sqrt{2}$     [C] 18    [D] 6
756. 080525a, P.I. A.A.27  
The solution set for the equation  $x^2 - 5x = 6$  is
- [A] {2,-3}                      [B] {1,-6}  
[C] {-2,3}                      [D] {-1,6}

757. 060124a, P.I. A.A.26

If a girl 1.2 meters tall casts a shadow 2 meters long, how many meters tall is a tree that casts a shadow 75 meters long at the same time?

758. 010303a, P.I. G.G.26

What is the inverse of the statement "If Mike did his homework, then he will pass this test"?

[A] If Mike did not do his homework, then he will not pass this test.

[B] If Mike passes this test, then he did his homework.

[C] If Mike does not pass this test, then he only did half his homework.

[D] If Mike does not pass this test, then he did not do his homework.

759. 060430a, P.I. A.A.28

If  $(x - 4)$  is a factor of  $x^2 - x - w = 0$ , then the value of  $w$  is

[A] -3    [B] -12    [C] 3    [D] 12

760. 080121a, P.I. G.G.32

Triangle  $ABC$ , with side  $\overline{AC}$  extended to  $D$ , is shown in the accompanying diagram. If  $m\angle ABC = 63$  and  $m\angle BCD = 92$ , what is  $m\angle BAC$ ?

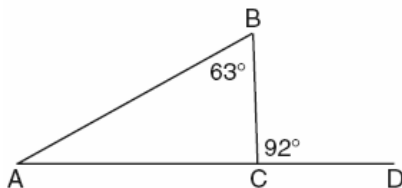

761. 010508a, P.I. A.A.45

The NuFone Communications Company must run a telephone line between two poles at opposite ends of a lake, as shown in the accompanying diagram. The length and width of the lake are 75 feet and 30 feet, respectively.

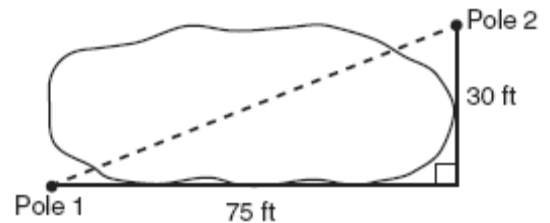

What is the distance between the two poles, to the nearest foot?

[A] 81    [B] 45    [C] 105    [D] 69

762. 060320a, P.I. A2.S.11

How many different five-member teams can be made from a group of eight students, if each student has an equal chance of being chosen?

[A] 40    [B] 56    [C] 336    [D] 6,720

763. 010833a, P.I. A.G.1

In the accompanying diagram of  $\triangle ABC$ , altitude  $BD = 4\sqrt{6}$  and  $AC = 5\sqrt{2}$ . Find the area of the triangle to the nearest tenth of a square unit.

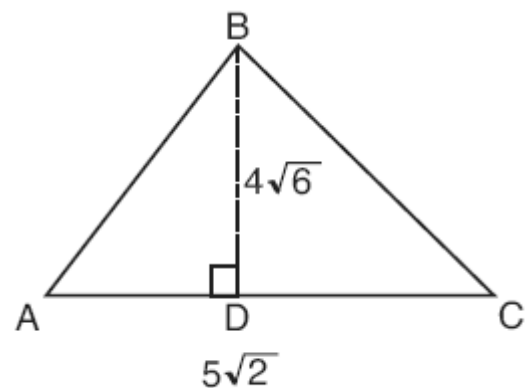

(Not drawn to scale)

764. 010130a, P.I. A.A.7  
Juan has a cellular phone that costs \$12.95 per month plus 25¢ per minute for each call. Tiffany has a cellular phone that costs \$14.95 per month plus 15¢ per minute for each call. For what number of minutes do the two plans cost the same?

765. 010727a, P.I. A.A.27  
What is the solution set of the equation  $x^2 - 5x = 0$ ?  
[A] {0,5} [B] {0} [C] {0,-5} [D] {5}

766. 060203a, P.I. A.RP.11  
The accompanying diagram shows the results of a survey asking which sports the members of the Key Club watch on television.

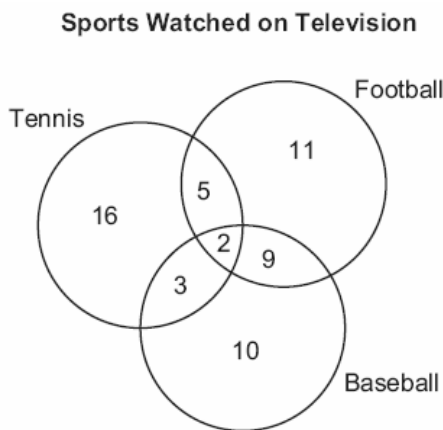

Which statement or statements are true?  
I The most watched sport is tennis.  
II The least watched sport is baseball.  
III More Key Club members watch tennis than football.

- [A] II, only [B] I and II, only  
[C] I, only [D] II and III, only

767. 010512a, P.I. 7.N.3  
If  $x^3 < x < \frac{1}{x}$ , then  $x$  could be equal to

- [A] 1 [B]  $\frac{6}{5}$  [C]  $\frac{1}{5}$  [D] 5

768. 080034a, P.I. A.N.8  
The telephone company has run out of seven-digit telephone numbers for an area code. To fix this problem, the telephone company will introduce a new area code. Find the number of new seven-digit telephone numbers that will be generated for the new area code if both of the following conditions must be met:  
o The first digit cannot be a zero or a one.  
o The first three digits cannot be the emergency number (911) or the number used for information (411).

769. 010801a, P.I. A.A.6  
Robin spent \$17 at an amusement park for admission and rides. If she paid \$5 for admission, and rides cost \$3 each, what is the total number of rides that she went on?  
[A] 2 [B] 12 [C] 9 [D] 4

770. 060514a, P.I. A.A.27  
What is the solution set of the equation  $x^2 + 11x + 28 = 0$ ?  
[A] {-7,-4} [B] {-7,4}  
[C] {-3,-4} [D] {3,4}

771. 010536a, P.I. A.A.21  
Find all negative odd integers that satisfy the following inequality:  $-3x + 1 \leq 17$

772. 060726a, P.I. 8.N.2  
If  $a = 3$  and  $b = -1$ , what is the value of  $ab - b^2$ ?  
[A] 4 [B] 2 [C] -4 [D] -2

773. 010405a, P.I. A.N.7  
In a school building, there are 10 doors that can be used to enter the building and 8 stairways to the second floor. How many different routes are there from outside the building to a class on the second floor?  
[A] 10 [B] 80 [C] 1 [D] 18

774. 010233a, P.I. A.A.8  
Javon's homework is to determine the dimensions of his rectangular backyard. He knows that the length is 10 feet more than the width, and the total area is 144 square feet. Write an equation that Javon could use to solve this problem. Then find the dimensions, in feet, of his backyard.

775. 080613a, P.I. 8.G.4  
In the accompanying diagram, line  $\ell$  is parallel to line  $m$ , and line  $t$  is a transversal.

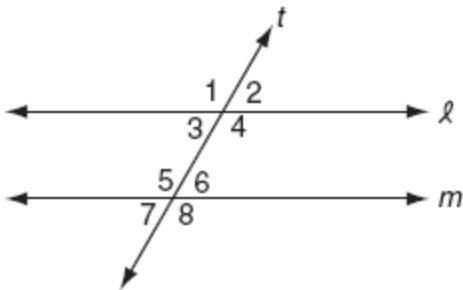

Which must be a true statement?

- [A]  $m\angle 3 + m\angle 6 = 180$   
[B]  $m\angle 1 + m\angle 8 = 180$   
[C]  $m\angle 2 + m\angle 5 = 180$   
[D]  $m\angle 1 + m\angle 4 = 180$
776. 010734a, P.I. A.M.2  
The formula  $C = \frac{5}{9}(F - 32)$  is used to convert Fahrenheit temperature,  $F$ , to Celsius temperature,  $C$ . What temperature, in degrees Fahrenheit, is equivalent to a temperature of  $10^\circ$  Celsius?

777. 060601a, P.I. 8.G.1  
In the accompanying diagram, line  $a$  intersects line  $b$ .



What is the value of  $x$ ?

- [A] 90 [B] -10 [C] 10 [D] 5
778. 010615a, P.I. G.G.48  
A builder is building a rectangular deck with dimensions of 16 feet by 30 feet. To ensure that the sides form  $90^\circ$  angles, what should each diagonal measure?
- [A] 34 ft [B] 16 ft [C] 30 ft [D] 46 ft

779. 010701a, P.I. G.G.56  
Which image represents a line reflection?

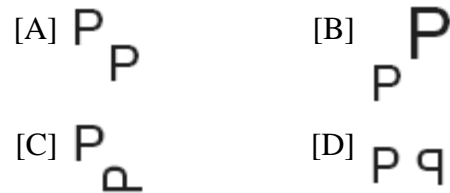

780. 060233a, P.I. A.N.5  
Mr. Perez owns a sneaker store. He bought 350 pairs of basketball sneakers and 150 pairs of soccer sneakers from the manufacturers for \$62,500. He sold all the sneakers and made a 25% profit. If he sold the soccer sneakers for \$130 per pair, how much did he charge for one pair of basketball sneakers?

781. 010201a, P.I. A.A.19  
Expressed in factored form, the binomial  $4a^2 - 9b^2$  is equivalent to
- [A]  $(2a + 3b)(2a - 3b)$   
[B]  $(2a - 3b)(2a - 3b)$   
[C]  $(2a - 9b)(2a + b)$  [D]  $(4a - 3b)(a + 3b)$

782. 010729a, P.I. A2.S.11  
If the Math Olympiad Club consists of eighteen students, how many different teams of four students can be formed for competitions?

[A] 73,440 [B] 66 [C] 3,060 [D] 72

783. 060732a, P.I. A.RP.11  
Jose surveyed 20 of his friends to find out what equipment they use to play recorded movies. He found that 12 of his friends have only DVD players, 5 have both DVD players and VCRs, and 2 have neither type of player. The rest of his friends have only VCRs. What is the total number of his friends that have VCRs?

784. 010119a, P.I. G.G.30, G.G.48  
In which of the accompanying figures are segments  $XY$  and  $YZ$  perpendicular?

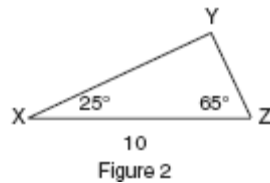
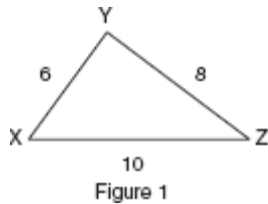

- [A] figure 2 only  
[B] both figure 1 and figure 2  
[C] figure 1, only  
[D] neither figure 1 nor figure 2

785. 060439a  
Solve the following system of equations algebraically or graphically:

$$x^2 + y^2 = 25$$

$$3y - 4x = 0$$

[The use of the accompanying grid is optional.]

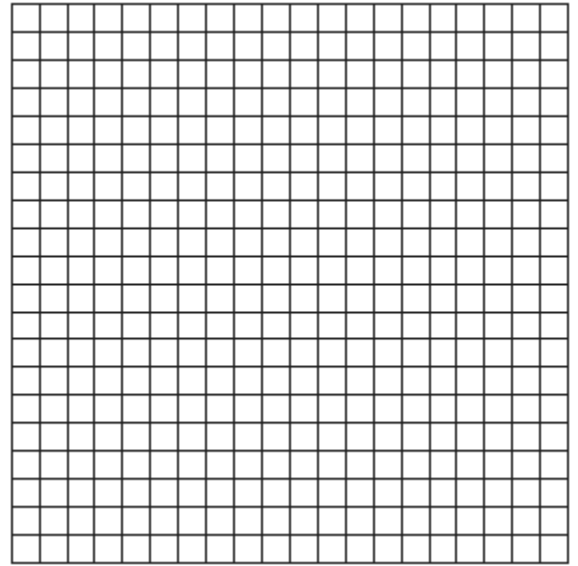

786. 010316a, P.I. A.A.42  
In the accompanying diagram of right triangle  $ABC$ ,  $AB = 8$ ,  $BC = 15$ ,  $AC = 17$ , and  $m\angle ABC = 90$ .

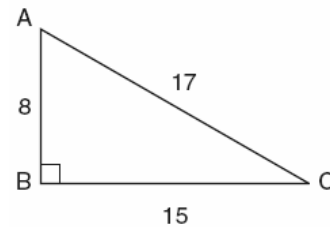

What is  $\tan \angle C$ ?

- [A]  $\frac{17}{15}$  [B]  $\frac{15}{17}$  [C]  $\frac{8}{17}$  [D]  $\frac{8}{15}$

787. 080404a, P.I. A.N.7  
The school cafeteria offers five sandwich choices, four desserts, and three beverages. How many different meals consisting of one sandwich, one dessert, and one beverage can be ordered?  
[A] 12 [B] 1 [C] 3 [D] 60

788. 010214a  
Frank, George, and Hernando are a plumber, a cabinet maker, and an electrician, though not necessarily in that order. Each can do all work appropriate to his own field, but no work in other fields. Frank was not able to install a new electric line in his home. Hernando was not able to make cabinets. George is also a building contractor who hired one of the other people to do his electrical work. Which statement must be true?  
[A] Hernando is an electrician.  
[B] George is a cabinet maker.  
[C] Frank is an electrician.  
[D] Frank is a plumber.

789. 010739a, P.I. A.S.5  
The accompanying table shows the weights, in pounds, for the students in an algebra class. Using the data, complete the cumulative frequency table and construct a cumulative frequency histogram on the grid below.

Interval	Frequency	Cumulative Frequency
91–100	6	
101–110	3	
111–120	0	
121–130	3	
131–140	0	
141–150	2	
151–160	2	

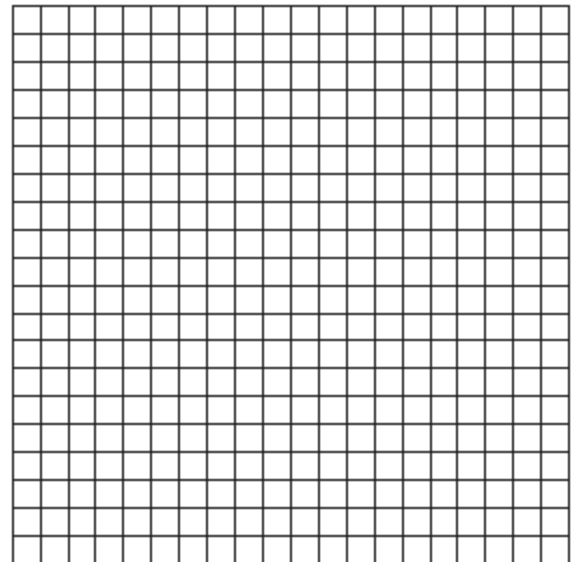

790. 060117a, P.I. A.A.7  
A hotel charges \$20 for the use of its dining room and \$2.50 a plate for each dinner. An association gives a dinner and charges \$3 a plate but invites four nonpaying guests. If each person has one plate, how many paying persons must attend for the association to collect the exact amount needed to pay the hotel?  
[A] 60 [B] 20 [C] 40 [D] 44



791. 089909a, P.I. G.G.39

In the accompanying diagram of rectangle ABCD,  $m\angle BAC = 3x + 4$  and  $m\angle ACD = x + 28$ .

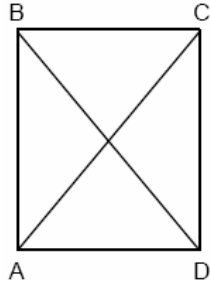

What is  $m\angle CAD$ ?

- [A] 40    [B] 37    [C] 12    [D] 50

792. 010815a, P.I. A.RP.11

A school newspaper took a survey of 100 students. The results of the survey showed that 43 students are fans of the Buffalo Bills, 27 students are fans of the New York Jets, and 48 students do not like either team. How many of the students surveyed are fans of *both* the Buffalo Bills and the New York Jets?

- [A] 18    [B] 52    [C] 16    [D] 70

793. 060539a, P.I. A.A.43

The accompanying diagram shows a flagpole that stands on level ground. Two cables,  $r$  and  $s$ , are attached to the pole at a point 16 feet above the ground. The combined length of the two cables is 50 feet. If cable  $r$  is attached to the ground 12 feet from the base of the pole, what is the measure of the angle,  $x$ , to the *nearest degree*, that cable  $s$  makes with the ground?

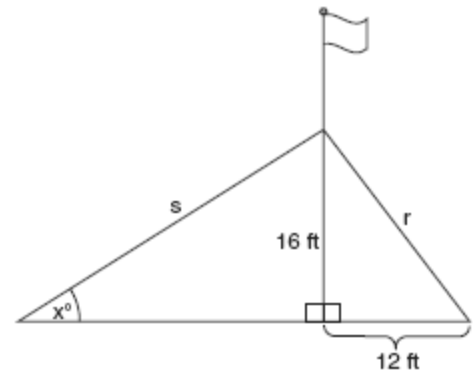

794. 080120a, P.I. G.G.25

What is the smallest integer greater than 1 that is both the square of an integer and the cube of an integer?

- [A] 9    [B] 36    [C] 64    [D] 8

795. 010328a, P.I. A.G.4

The graph of a quadratic equation is shown in the accompanying diagram. The scale on the axes is a unit scale. Write an equation of this graph in standard form.

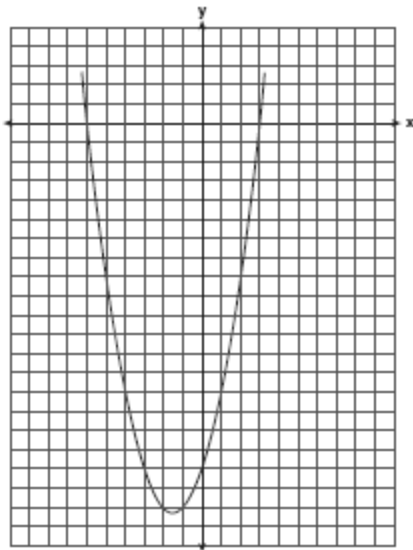

796. 010224a, P.I. A.A.1

Ashanti and Maria went to the store to buy snacks for their back-to-school party. They bought bags of chips, pretzels, and nachos. They bought three times as many bags of pretzels as bags of chips, and two fewer bags of nachos than bags of pretzels. If  $x$  represents the number of bags of chips they bought, express, in terms of  $x$ , how many bags of snacks they bought in all.

797. 010711a

A planned building was going to be 100 feet long, 75 feet deep, and 30 feet high. The owner decides to increase the volume of the building by 10% without changing the dimensions of the depth and the height. What will be the new length of this building?

- [A] 108 ft                      [B] 112 ft  
[C] 106 ft                      [D] 110 ft

798. 080218a, P.I. A.A.23

If  $2m + 2p = 16$ ,  $p$  equals

- [A]  $16 - m$                       [B]  $16 + 2m$   
[C]  $9m$                               [D]  $8 - m$

799. 080119a, P.I. A2.A.9

Which expression is equivalent to  $x^{-1} \cdot y^2$ ?

- [A]  $\frac{y^2}{x}$     [B]  $xy^2$     [C]  $xy^{-2}$     [D]  $\frac{x}{y^2}$

800. 080724a, P.I. A.A.44

The accompanying diagram shows a ramp 30 feet long leaning against a wall at a construction site.

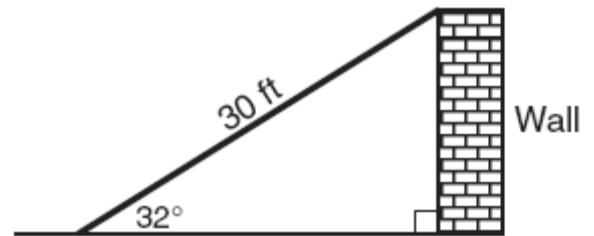

If the ramp forms an angle of  $32^\circ$  with the ground, how high above the ground, to the nearest tenth, is the top of the ramp?

- [A] 56.6 ft                      [B] 15.9 ft  
[C] 25.4 ft                      [D] 18.7 ft

801. 060003a, P.I. 7.N.2

Which number is rational?

- [A]  $\sqrt{\frac{3}{2}}$     [B]  $\pi$     [C]  $\frac{5}{4}$     [D]  $\sqrt{7}$

802. 010518a, P.I. A.N.6

The expression  $-|-7|$  is equivalent to

- [A] -7    [B] 1    [C] 0    [D] 7

803. 060219a, P.I. A.A.23

If  $x = 2a - b^2$ , then  $a$  equals

- [A]  $\frac{b^2 - x}{2}$                       [B]  $x + b^2$   
 [C]  $\frac{x + b^2}{2}$                       [D]  $\frac{x - b^2}{2}$

804. 010807a, P.I. A.A.22

What is the value of  $p$  in the equation

$$8p + 2 = 4p - 10?$$

- [A] 1            [B] -3            [C] 3            [D] -1

805. 060738a, P.I. A.A.6

Angelo, Brandon, and Carl work in the same office. Angelo's age is 4 years more than twice Carl's age. Brandon is 5 years younger than Carl. The average of the three ages is 41. Find the age of *each* of the men.

806. 010218a

When Kimberly bought her new car, she found that there were 72 different ways her car could be equipped. Her choices included four choices of engine and three choices of transmission. If her only other choice was color, how many choices of color did she have?

- [A] 6            [B] 60            [C] 65            [D] 12

807. 010802a, P.I. A.G.2

A block of wood is 5 inches long, 2 inches wide, and 3 inches high. What is the volume of this block of wood?

- [A]  $30 \text{ in}^3$                       [B]  $25 \text{ in}^3$   
 [C]  $38 \text{ in}^3$                       [D]  $10 \text{ in}^3$

808. 010010a, P.I. G.G.33

A plot of land is in the shape of rhombus  $ABCD$  as shown below.

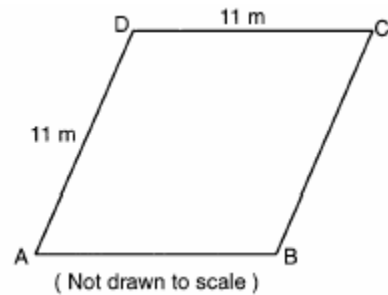

Which can *not* be the length of diagonal  $AC$ ?

- [A] 24 m    [B] 11 m    [C] 4 m    [D] 18 m

809. 080011a, P.I. A.S.20

A box contains six black balls and four white balls. What is the probability of selecting a black ball at random from the box?

- [A]  $\frac{6}{10}$     [B]  $\frac{4}{6}$     [C]  $\frac{6}{4}$     [D]  $\frac{1}{10}$

810. 080718a, P.I. 7.N.2

Which number is irrational?

- [A]  $\pi$     [B]  $\frac{5}{4}$     [C]  $\sqrt{121}$     [D]  $0.\bar{3}$

811. 010005a, P.I. 6.S.5

What was the median high temperature in Middletown during the 7-day period shown in the table below?

Daily High Temperature in Middletown	
Day	Temperature (°F)
Sunday	68
Monday	73
Tuesday	73
Wednesday	75
Thursday	69
Friday	67
Saturday	63

- [A] 75    [B] 70    [C] 73    [D] 69

812. 010834a, P.I. G.G.64  
Write an equation of a line that is perpendicular to the line  $y = \frac{2}{3}x + 5$  and that passes through the point (0,4).

813. 010638a, P.I. A.A.44  
As shown in the accompanying diagram, a ladder is leaning against a vertical wall, making an angle of  $70^\circ$  with the ground and reaching a height of 10.39 feet on the wall. Find, to the nearest foot, the length of the ladder. Find, to the nearest foot, the distance from the base of the ladder to the wall.

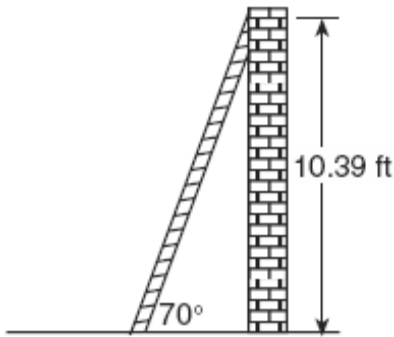

814. 010123a, P.I. A.G.2  
A cardboard box has length  $x - 2$ , width  $x + 1$ , and height  $2x$ .  
a Write an expression, in terms of  $x$ , to represent the volume of the box.  
b If  $x = 8$  centimeters, what is the number of cubic centimeters in the volume of the box?

815. 060313a, P.I. A.A.27  
What is the solution set of the equation  $x^2 - 5x - 24 = 0$ ?

- [A] {3,-8}                      [B] {-3,8}  
[C] {-3,-8}                    [D] {3,8}

816. 010523a, P.I. A.A.13  
When  $3x^2 - 8x$  is subtracted from  $2x^2 + 3x$ , the difference is

- [A]  $x^2 - 5x$                     [B]  $-x^2 - 5x$   
[C]  $-x^2 - 11x$                 [D]  $-x^2 + 11x$

817. 069909a, P.I. A.A.28  
The larger root of the equation  $(x + 4)(x - 3) = 0$  is

- [A] -3      [B] 3      [C] 4      [D] -4

818. 010421a, P.I. A.A.23  
If  $2ax - 5x = 2$ , then  $x$  is equivalent to

- [A]  $7 - 2a$                       [B]  $\frac{2 + 5a}{2a}$   
[C]  $\frac{1}{a - 5}$                         [D]  $\frac{2}{2a - 5}$

819. 010310a, P.I. A.A.23  
The equation  $P = 2L + 2W$  is equivalent to

- [A]  $L = \frac{P - 2W}{2}$                     [B]  $L = \frac{P + 2W}{2}$   
[C]  $L = P - W$                     [D]  $2L = \frac{P}{2W}$

820. 080414a, P.I. A.A.42  
Which ratio represents  $\cos A$  in the accompanying diagram of  $\triangle ABC$ ?

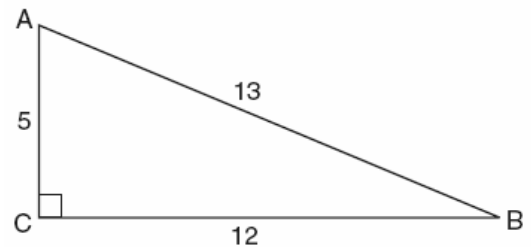

- [A]  $\frac{13}{5}$       [B]  $\frac{5}{13}$       [C]  $\frac{12}{13}$       [D]  $\frac{12}{5}$

821. 010318a, P.I. A.A.20  
What are the factors of  $x^2 - 10x - 24$ ?

- [A]  $(x + 12)(x - 2)$             [B]  $(x - 4)(x - 6)$   
[C]  $(x - 12)(x + 2)$             [D]  $(x - 4)(x + 6)$

822. 080012a, P.I. A.A.27

The solution set for the equation  $x^2 - 2x - 15 = 0$  is

- [A]  $\{-5, 3\}$                       [B]  $\{-5, -3\}$   
[C]  $\{5, 3\}$                         [D]  $\{5, -3\}$

823. 060305a, P.I. A.S.23

Bob and Laquisha have volunteered to serve on the Junior Prom Committee. The names of twenty volunteers, including Bob and Laquisha, are put into a bowl. If two names are randomly drawn from the bowl without replacement, what is the probability that Bob's name will be drawn first and Laquisha's name will be drawn second?

- [A]  $\frac{1}{20} \cdot \frac{1}{20}$                       [B]  $\frac{2}{20}$   
[C]  $\frac{2}{20!}$                             [D]  $\frac{1}{20} \cdot \frac{1}{19}$

824. 010211a, P.I. 7.A.10

If  $x$  and  $y$  are defined as indicated by the accompanying table, which equation correctly represents the relationship between  $x$  and  $y$ ?

$x$	$y$
2	1
3	3
5	7
7	11

- [A]  $y = 2x - 3$                       [B]  $y = 2x + 2$   
[C]  $y = 2x + 3$                       [D]  $y = x + 2$

825. 010002a, P.I. 7.N.3

Which number has the greatest value?

- [A]  $\sqrt{2}$     [B]  $1\frac{2}{3}$     [C] 1.5    [D]  $\frac{\pi}{2}$

826. 080736a, P.I. A.M.1

The trip from Manhattan to Montauk Point is 120 miles by train or by car. A train makes the trip in 2 hours, while a car makes the trip in  $2\frac{1}{2}$  hours. How much faster, in miles per hour, is the average speed of the train than the average speed of the car?

827. 060120a, P.I. 7.N.2

Which is a rational number?

- [A]  $6\sqrt{2}$     [B]  $5\sqrt{9}$     [C]  $\pi$     [D]  $\sqrt{8}$

828. 010226a, P.I. G.G.67

Jerry and Jean Jogger start at the same time from point A shown on the accompanying set of axes. Jerry jogs at a rate of 5 miles per hour traveling from point A to point R to point S and then to point C. Jean jogs directly from point A to point C on  $\overline{AC}$  at the rate of 3 miles per hour. Which jogger reaches point C first? Explain or show your reasoning.

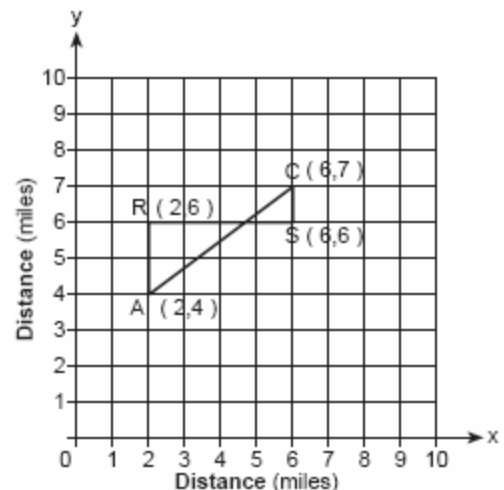

829. 080408a, P.I. 8.N.2

If  $x = -4$  and  $y = 3$ , what is the value of  $x - 3y^2$ ?

- [A] -85    [B] -13    [C] -23    [D] -31

830. 080617a, P.I. 8.N.2

If  $x = 4$  and  $y = -2$ , the value of  $\frac{1}{2}xy^2$  is

- [A] 8      [B] -4      [C] -8      [D] 32

831. 080212a, P.I. G.G.56

In the accompanying diagram, which transformation changes the solid-line parabola to the dotted-line parabola?

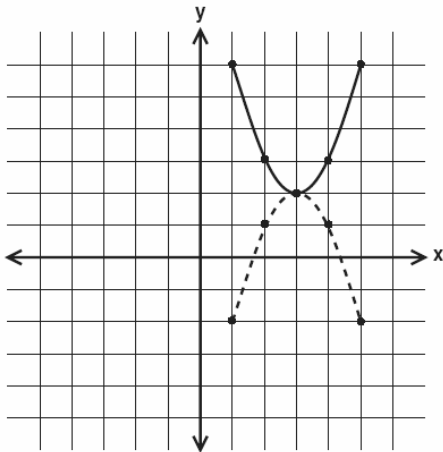

- [A] translation      [B] line reflection, only  
[C] rotation, only  
[D] line reflection or rotation

832. 060525a, P.I. 7.N.11

If  $a$  and  $b$  are both odd integers, which expression must always equal an odd integer?

- [A]  $a + b$       [B]  $a \cdot b$       [C]  $\frac{a}{b}$       [D]  $a - b$

833. 010816a, P.I. 7.N.3

In which group are the numbers arranged in order from smallest value to largest value?

[A]  $\frac{22}{7}$ , 3.14,  $\pi$ ,  $\sqrt{9.86}$

[B]  $\pi$ , 3.14,  $\sqrt{9.86}$ ,  $\frac{22}{7}$

[C] 3.14,  $\sqrt{9.86}$ ,  $\pi$ ,  $\frac{22}{7}$

[D]  $\sqrt{9.86}$ ,  $\frac{22}{7}$ , 3.14,  $\pi$

834. 010020a, P.I. G.G.22

The distance between parallel lines  $\ell$  and  $m$  is 12 units. Point  $A$  is on line  $\ell$ . How many points are equidistant from lines  $\ell$  and  $m$  and 8 units from point  $A$ ?

- [A] 2      [B] 4      [C] 3      [D] 1

835. 080009a, P.I. A.A.38

Which equation represents a line parallel to the line  $y = 2x - 5$ ?

[A]  $y = -\frac{1}{2}x - 5$       [B]  $y = 2x + 5$

[C]  $y = 5x - 2$       [D]  $y = -2x - 5$

836. 010019a, P.I. A.A.13

When  $3a^2 - 2a + 5$  is subtracted from  $a^2 + a - 1$ , the result is

[A]  $-2a^2 + 3a + 6$       [B]  $2a^2 - 3a - 6$

[C]  $2a^2 - 3a + 6$       [D]  $-2a^2 + 3a - 6$

837. 069910a, P.I. A.N.5

Linda paid \$48 for a jacket that was on sale for 25% of the original price. What was the original price of the jacket?

- [A] \$72      [B] \$60      [C] \$96      [D] \$192

838. 080210a, P.I. 7.N.5  
If  $0.0347$  is written by a scientist in the form  $3.47 \times 10^n$ , the value of  $n$  is  
[A] -2 [B] 3 [C] 2 [D] -3

839. 069918a, P.I. 8.G.13  
What is the slope of line  $\ell$  shown in the accompanying diagram?

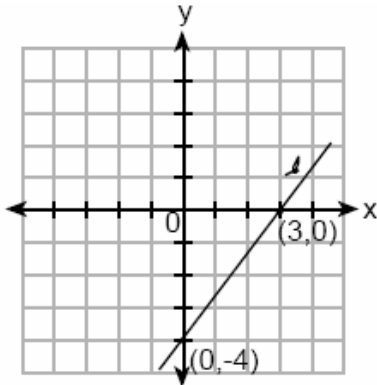

- [A]  $\frac{4}{3}$  [B]  $\frac{3}{4}$  [C]  $-\frac{4}{3}$  [D]  $-\frac{3}{4}$

840. 089931a, P.I. A.A.26  
The profits in a business are to be shared by the three partners in the ratio of 3 to 2 to 5. The profit for the year was \$176,500. Determine the number of dollars each partner is to receive.

841. 010531a, P.I. A.A.44  
In the accompanying diagram, a ladder leaning against a building makes an angle of  $58^\circ$  with level ground. If the distance from the foot of the ladder to the building is 6 feet, find, to the nearest foot, how far up the building the ladder will reach.



842. 060420a, P.I. A.N.5  
Rashawn bought a CD that cost \$18.99 and paid \$20.51, including sales tax. What was the rate of the sales tax?  
[A] 5% [B] 2% [C] 3% [D] 8%

843. 080510a, P.I. 8.A.12  
The accompanying diagram shows two parallel streets, Main Street and Brooks Road, intersected by Jay Street. The obtuse angle that Jay Street forms with Brooks Road is three times the measure of the acute angle that Jay Street forms with Main Street.

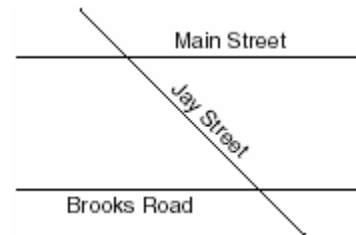

What is the measure of the acute angle formed by Jay Street and Main Street?

- [A]  $45^\circ$  [B]  $90^\circ$  [C]  $60^\circ$  [D]  $135^\circ$

844. 060625a, P.I. A.A.17  
The expression  $\frac{5x}{6} + \frac{x}{4}$  is equivalent to

- [A]  $\frac{3x}{5}$  [B]  $\frac{5x}{24}$  [C]  $\frac{13x}{12}$  [D]  $\frac{5x^2}{10}$

845. 010334a, P.I. A.S.5  
Sarah's mathematics grades for one marking period were 85, 72, 97, 81, 77, 93, 100, 75, 86, 70, 96, and 80.  
a Complete the tally sheet and frequency table below, and construct and label a frequency histogram for Sarah's grades using the accompanying grid.

Interval (grades)	Tally	Frequency
61–70		
71–80		
81–90		
91–100		

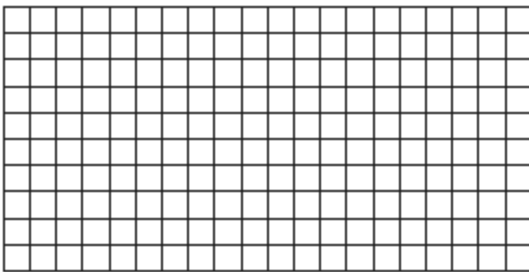

b Which interval contains the 75th percentile (upper quartile)?

846. 060616a, P.I. 8.G.19  
Which graph best represents the solution set for the inequality  $x > \sqrt{2}$ ?

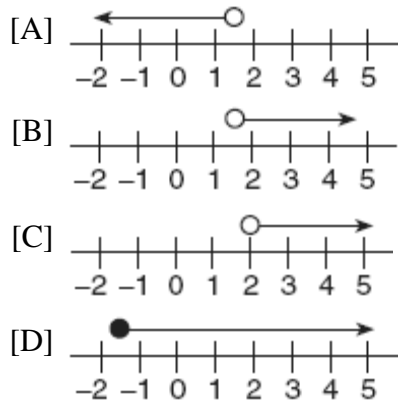

847. 060626a, P.I. G.G.38  
In the accompanying diagram of parallelogram  $ABCD$ , diagonals  $\overline{AC}$  and  $\overline{BD}$  intersect at  $E$ ,  $BE = \frac{2}{3}x$ , and  $ED = x - 10$ .

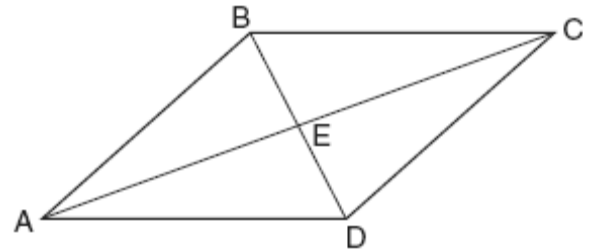

What is the value of  $x$ ?

- [A] 6 [B] -6 [C] -30 [D] 30

848. 080111a, P.I. A.N.7  
A certain car comes in three body styles with a choice of two engines, a choice of two transmissions, and a choice of six colors. What is the minimum number of cars a dealer must stock to have one car of every possible combination?

- [A] 13 [B] 36 [C] 42 [D] 72

849. 060101a, P.I. A.A.1  
A car travels 110 miles in 2 hours. At the same rate of speed, how far will the car travel in  $h$  hours?

- [A]  $55h$  [B]  $\frac{h}{55}$  [C]  $220h$  [D]  $\frac{h}{220}$

850. 080106a  
Which letter below has point symmetry, but does not have line symmetry?

- [A] N [B] H [C] A [D] E



851. 010031a, P.I. A.G.4

Amy tossed a ball in the air in such a way that the path of the ball was modeled by the equation  $y = -x^2 + 6x$ . In the equation,  $y$  represents the height of the ball in feet and  $x$  is the time in seconds.

a Graph  $y = -x^2 + 6x$  for  $0 \leq x \leq 6$  on the grid provided below.

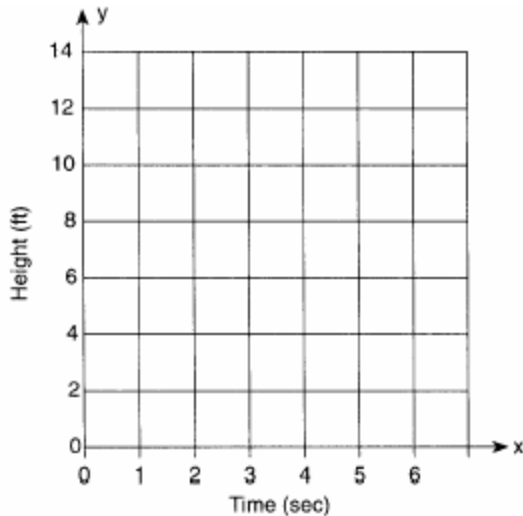

b At what time,  $x$ , is the ball at its highest point?

852. 060634a, P.I. A.A.22

Solve for  $x$ :  $3.3 - x = 3(x - 1.7)$

853. 010308a, P.I. G.G.26

Given the true statement: "If a person is eligible to vote, then that person is a citizen."  
Which statement must also be true?

- [A] Morgan has never voted; therefore, he is not a citizen.
- [B] Kayla is not a citizen; therefore, she is not eligible to vote.
- [C] Juan is a citizen; therefore, he is eligible to vote.
- [D] Marie is not eligible to vote; therefore, she is not a citizen.

854. 060001a, P.I. 8.G.19

Which inequality is represented in the graph below?

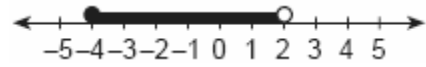

- [A]  $-4 \leq x \leq 2$
- [B]  $-4 < x \leq 2$
- [C]  $-4 < x < 2$
- [D]  $-4 \leq x < 2$

855. 080628a, P.I. A.A.39

Point  $(k, -3)$  lies on the line whose equation is  $x - 2y = -2$ . What is the value of  $k$ ?

- [A] -6
- [B] 6
- [C] -8
- [D] 8

856. 080201a, P.I. A.A.26

On a map, 1 centimeter represents 40 kilometers. How many kilometers are represented by 8 centimeters?

- [A] 320
- [B] 48
- [C] 5
- [D] 280

857. 080520a, P.I. G.G.33

Sara is building a triangular pen for her pet rabbit. If two of the sides measure 8 feet and 15 feet, the length of the third side could be

- [A] 7 ft
- [B] 13 ft
- [C] 23 ft
- [D] 3 ft

858. 010714a

The graph of the equation  $x^2 + y^2 = r^2$  forms

- [A] a straight line
- [B] a circle
- [C] a parabola
- [D] two intersecting lines

859. 069904a, P.I. A.A.13

The sum of  $3x^2 + x + 8$  and  $x^2 - 9$  can be expressed as

- [A]  $3x^4 + x - 1$
- [B]  $4x^4 + x - 1$
- [C]  $4x^2 + x - 17$
- [D]  $4x^2 + x - 1$

860. 080022a, P.I. A.A.18

Perform the indicated operation and express the result in simplest terms:  $\frac{x}{x+3} \div \frac{3x}{x^2-9}$

861. 080005a

Which table does *not* show an example of direct variation?

[A] 

$x$	$y$
-4	-20
-3	-15
-2	-10
-1	-5

[B] 

$x$	$y$
1	4
2	8
3	12
4	16

[C] 

$x$	$y$
1	$\frac{1}{2}$
2	1
3	$\frac{3}{2}$
4	2

[D] 

$x$	$y$
2	24
4	12
6	8
8	6

862. 060004a, P.I. A.A.7

Two numbers are in the ratio 2:5. If 6 is subtracted from their sum, the result is 50. What is the larger number?

- [A] 40    [B] 45    [C] 35    [D] 55

863. 080208a, P.I. 7.N.17

The number  $0.14114111411114\dots$  is

- [A] irrational            [B] rational  
[C] whole                 [D] integral

864. 080118a, P.I. A.A.27

What is the solution set of  $m^2 - 3m - 10 = 0$ ?

- [A] {5,-2}                [B] {3,-10}  
[C] {2,-5}                [D] {3,10}

865. 069913a, P.I. A.A.26

A total of \$450 is divided into equal shares. If Kate receives four shares, Kevin receives three shares, and Anna receives the remaining two shares, how much money did Kevin receive?

- [A] \$150                 [B] \$250  
[C] \$200                 [D] \$100

866. 080730a, P.I. A2.A.8

The expression  $(\frac{3}{4})^2 \cdot (\frac{1}{4})^{-2}$  is equivalent to

- [A]  $\frac{9}{256}$             [B]  $\frac{9}{16}$             [C] 9            [D] 3

867. 060429a, P.I. A.N.4

If the mass of a proton is  $1.67 \times 10^{-24}$  gram, what is the mass of 1,000 protons?

- [A]  $1.67 \times 10^{-27}$             [B]  $1.67 \times 10^{-21}$   
[C]  $1.67 \times 10^{-23}$             [D]  $1.67 \times 10^{-22}$

868. 080508a, P.I. A.A.8

The height of a golf ball hit into the air is modeled by the equation  $h = -16t^2 + 48t$ , where  $h$  represents the height, in feet, and  $t$  represents the number of seconds that have passed since the ball was hit. What is the height of the ball after 2 seconds?

- [A] 64 ft    [B] 80 ft    [C] 16 ft    [D] 32 ft

869. 069903a, P.I. G.G.61

What is the image of point (2,5) under the translation that shifts  $(x,y)$  to  $(x+3, y-2)$ ?

- [A] (0,8)    [B] (0,3)    [C] (5,8)    [D] (5,3)

870. 010121a, P.I. 8.A.3

The accompanying graph shows Marie's distance from home (A) to work (F) at various times during her drive.

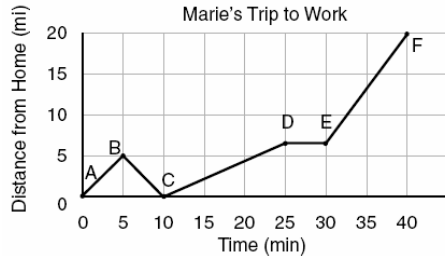

- a Marie left her briefcase at home and had to return to get it. State which point represents when she turned back around to go home and explain how you arrived at that conclusion.  
b Marie also had to wait at the railroad tracks for a train to pass. How long did she wait?

871. 060318a, P.I. A.A.20

If one factor of  $56x^4y^3 - 42x^2y^6$  is  $14x^2y^3$ , what is the other factor?

- [A]  $4x^2 - 3y^3$                       [B]  $4x^2y - 3xy^2$   
[C]  $4x^2y - 3xy^3$                       [D]  $4x^2 - 3y^2$

872. 080529a, P.I. G.G.63

When solved graphically, which system of equations will have exactly one point of intersection?

- [A]  $y = \frac{3}{5}x + 12$                       [B]  $y = 0.5x + 30$   
 $y = 0.6x - 19$      $y = 0.5x - 30$   
[C]  $y = -x + 15$                       [D]  $y = -x - 20$   
 $y = -x + 25$      $y = x + 17$

873. 080603a, P.I. A.A.26

Jordan and Missy are standing together in the schoolyard. Jordan, who is 6 feet tall, casts a shadow that is 54 inches long. At the same time, Missy casts a shadow that is 45 inches long. How tall is Missy?

- [A] 5 ft                                      [B] 86.4 in  
[C] 5 ft 6 in                              [D] 38 in

874. 060407a, P.I. A.M.2

If the temperature in Buffalo is  $23^\circ$  Fahrenheit, what is the temperature in degrees Celsius? [Use the formula  $C = \frac{5}{9}(F - 32)$ .]

- [A] -5                      [B] 5                      [C] -45                      [D] 45

875. 010538a, P.I. G.G.30

In  $\triangle ABC$ , the measure of  $\angle B$  is 21 less than four times the measure of  $\angle A$ , and the measure of  $\angle C$  is 1 more than five times the measure of  $\angle A$ . Find the measure, in degrees, of each angle of  $\triangle ABC$ .

876. 069924a, P.I. A.A.16

Simplify:  $\frac{9x^2 - 15xy}{9x^2 - 25y^2}$

877. 060306a, P.I. A.N.1

Tori computes the value of  $8 \times 95$  in her head by thinking  $8(100 - 5) = 8 \times 100 - 8 \times 5$ .

Which number property is she using?

- [A] associative                      [B] distributive  
[C] commutative                      [D] closure

878. 060132a, P.I. A.G.1

Keesha wants to tile the floor shown in the accompanying diagram. If each tile measures 1 foot by 1 foot and costs \$2.99, what will be the total cost, including an 8% sales tax, for tiling the floor?

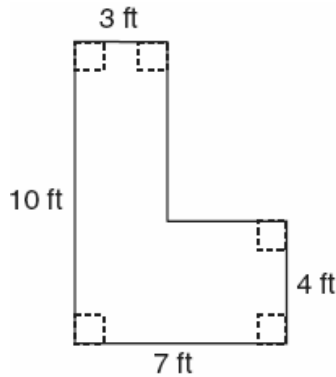

879. 069923a, P.I. 7.N.2

Which number below is irrational?

$$\sqrt{\frac{4}{9}}, \sqrt{20}, \sqrt{121}$$

Why is the number you chose an irrational number?

880. 080539a, P.I. A.G.1

Mr. Petri has a rectangular plot of land with length = 20 feet and width = 10 feet. He wants to design a flower garden in the shape of a circle with two semicircles at each end of the center circle, as shown in the accompanying diagram. He will fill in the shaded area with wood chips. If one bag of wood chips covers 5 square feet, how many bags must he buy?

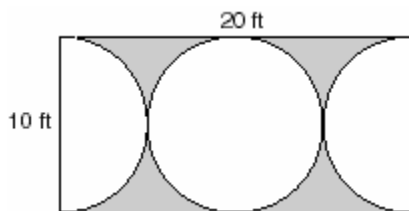

881. 060324a, P.I. 8.A.12

In the accompanying diagram, line  $m$  is parallel to line  $p$ , line  $t$  is a transversal,  $m\angle a = 3x + 12$ , and  $m\angle b = 2x + 13$ . Find the value of  $x$ .

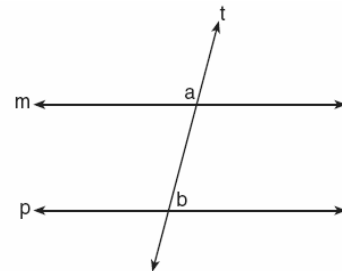

882. 010619a, P.I. A.A.13

When  $3a^2 - 7a + 6$  is subtracted from  $4a^2 - 3a + 4$ , the result is

[A]  $a^2 - 10a - 2$       [B]  $a^2 + 4a - 2$

[C]  $7a^2 - 10a + 10$       [D]  $-a^2 - 4a + 2$

883. 080227a, P.I. A.A.6

Tamika could not remember her scores from five mathematics tests. She did remember that the mean (average) was exactly 80, the median was 81, and the mode was 88. If all her scores were integers with 100 the highest score possible and 0 the lowest score possible, what was the *lowest* score she could have received on any one test?

884. 080635a, P.I. A.N.5

A recent survey shows that the average man will spend 141,288 hours sleeping, 85,725 hours working, 81,681 hours watching television, 9,945 hours commuting, 1,662 hours kissing, and 363,447 hours on other tasks during his lifetime. What percent of his life, to the *nearest tenth of a percent*, does he spend sleeping?

885. 010409a, P.I. G.G.22

In the accompanying diagram, line  $\ell_1$  is parallel to line  $\ell_2$ .

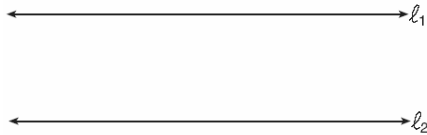

Which term describes the locus of all points that are equidistant from line  $\ell_1$  and  $\ell_2$ ?

- [A] point                      [B] rectangle  
[C] line                        [D] circle

886. 010323a, P.I. A.N.8

Six members of a school's varsity tennis team will march in a parade. How many different ways can the players be lined up if Angela, the team captain, is always at the front of the line?

887. 060319a, P.I. A.A.15

For which value of  $x$  is the expression  $\frac{3x-6}{x-4}$  undefined?

- [A] -4      [B] 4      [C] 2      [D] 0

888. 060334a, G.G.48

A straw is placed into a rectangular box that is 3 inches by 4 inches by 8 inches, as shown in the accompanying diagram. If the straw fits exactly into the box diagonally from the bottom left front corner to the top right back corner, how long is the straw, to the *nearest tenth of an inch*?

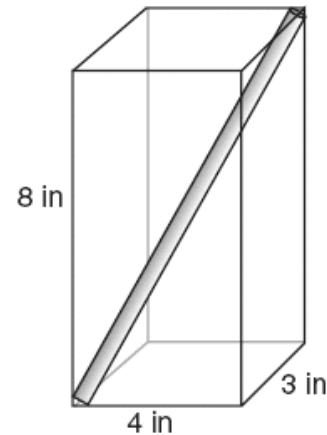

889. 060021a, P.I. A.M.2

The formula for changing Celsius (C) temperature to Fahrenheit (F) temperature is  $F = \frac{9}{5}C + 32$ . Calculate, to the *nearest degree*, the Fahrenheit temperature when the Celsius temperature is -8.

890. 080123a, P.I. A.A.13

Subtract  $5x^2 - 7x - 6$  from  $9x^2 + 3x - 4$ .

891. 089922a, P.I. A.S.19

The Grimaldis have three children born in different years.

- a* Draw a tree diagram or list a sample space to show all the possible arrangements of boy and girl children in the Grimaldi family.  
*b* Using your information from part *a*, what is the probability that the Grimaldis have three boys?

892. 060226a, P.I. 8.A.12  
Two parallel roads, Elm Street and Oak Street, are crossed by a third, Walnut Street, as shown in the accompanying diagram. Find the number of degrees in the acute angle formed by the intersection of Walnut Street and Elm Street.

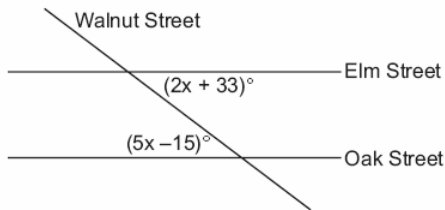

893. 010808a, P.I. A.A.27  
A solution of the equation  $\frac{x^2}{4} = 9$  is
- [A] 12    [B] 3    [C]  $\frac{3}{2}$     [D] 6

894. 060702a, P.I. A.A.22  
What is the value of  $x$  in the equation  $6(x - 2) = 36 - 10x$ ?
- [A] 3    [B] 1.5    [C] 6    [D] -6

895. 080504a, P.I. A.N.1  
The equation  $*(\Delta + \diamond) = * \Delta + * \diamond$  is an example of the
- [A] distributive law    [B] associative law  
[C] commutative law    [D] transitive law

896. 060228a, P.I. A.G.1  
As shown in the accompanying diagram, radio station KMA is increasing its radio listening radius from 40 miles to 50 miles. How many additional square miles of listening area, to the *nearest tenth*, will the radio station gain?

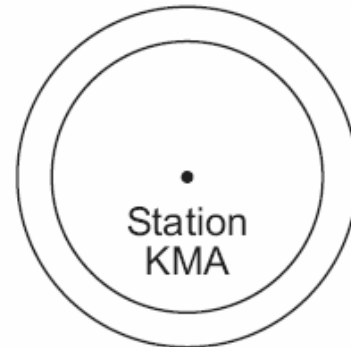

897. 010221a, P.I. G.G.25  
Seth is thinking of a number between 20 and 30. The number is prime and not more than 2 away from a perfect square. What is the number?
898. 080713a, P.I. G.G.54  
What are the coordinates of point  $(2, -3)$  after it is reflected over the  $x$ -axis?
- [A]  $(2, 3)$     [B]  $(-3, 2)$   
[C]  $(-2, -3)$     [D]  $(-2, 3)$
899. 080105a, P.I. A.G.1  
In the accompanying diagram, a circle with radius 4 is inscribed in a square.

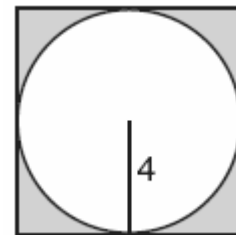

What is the area of the shaded region?

- [A]  $64\pi - 8\pi$     [B]  $16 - 16\pi$   
[C]  $16 - 8\pi$     [D]  $64 - 16\pi$

900. 010610a, P.I. 8.G.19

In order to be admitted for a certain ride at an amusement park, a child must be greater than or equal to 36 inches tall and less than 48 inches tall. Which graph represents these conditions?

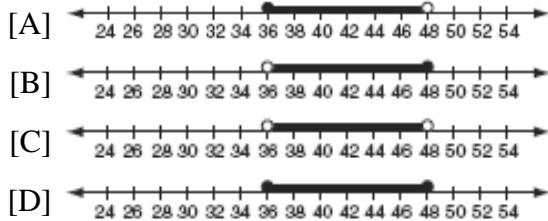

901. 010319a, P.I. A.N.4

What is the value of  $\frac{6.3 \times 10^8}{3 \times 10^4}$  in scientific notation?

- [A]  $2.1 \times 10^{-4}$       [B]  $2.1 \times 10^2$   
[C]  $2.1 \times 10^{-2}$       [D]  $2.1 \times 10^4$

902. 060303a, P.I. 7.N.2

Which expression represents an irrational number?

- [A] 0.17    [B]  $\frac{1}{2}$     [C] 0    [D]  $\sqrt{2}$

903. 080501a, P.I. A.S.4

The weights of all the students in grade 9 are arranged from least to greatest. Which statistical measure separates the top half of this set of data from the bottom half?

- [A] median      [B] mean  
[C] average      [D] mode

904. 010809a

Which transformation produces a figure that is always the mirror image of the original figure?

- [A] rotation      [B] dilation  
[C] translation      [D] line reflection

905. 010617a, P.I. A.G.1

A dog is tied with a rope to a stake in the ground. The length of the rope is 5 yards. What is the area, in square yards, in which the dog can roam?

- [A]  $25\pi$     [B] 25    [C]  $10\pi$     [D] 20

906. 060232a, P.I. A.A.7

At Ron's Rental, a person can rent a big-screen television for \$10 a month plus a one-time "wear-and-tear" fee of \$100. At Josie's Rental, the charge is \$20 a month and an additional charge of \$20 for delivery with no "wear-and-tear" fee.

*a* If  $c$  equals the cost, write one equation representing the cost of the rental for  $m$  months at Ron's Rental and one equation representing the cost of the rental for  $m$  months at Josie's Rental.

*b* On the accompanying grid, graph and label each equation.

*c* From your graph, determine in which month Josie's cost will equal Ron's cost.

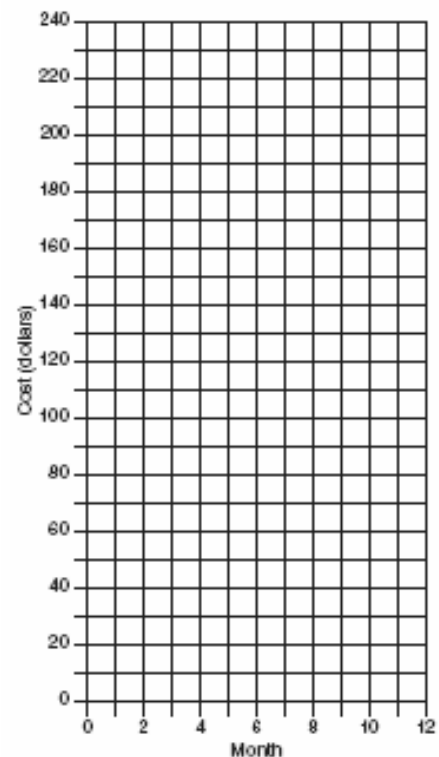

907. 060317a, P.I. G.G.26  
What is the inverse of the statement "If Julie works hard, then she succeeds"?
- [A] If Julie works hard, then she does not succeed.
- [B] If Julie does not succeed, then she does not work hard.
- [C] If Julie does not work hard, then she does not succeed.
- [D] If Julie succeeds, then she works hard.

908. 060730a, P.I. G.G.26  
Given the statement: "A right angle measures  $90^\circ$ ." How is this statement written as a biconditional?
- [A] If an angle is a right angle, then it measures  $90^\circ$ .
- [B] If an angle does not measure  $90^\circ$ , then it is not a right angle.
- [C] An angle measures  $90^\circ$  and it is a right angle.
- [D] An angle is a right angle if, and only if, it measures  $90^\circ$ .

909. 080403a  
Which diagram represents the figure with the greatest volume?

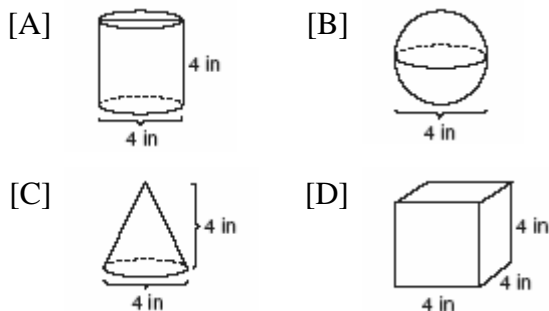

910. 010105a, P.I. A.A.19  
One of the factors of  $4x^2 - 9$  is
- [A]  $(2x + 3)$  [B]  $(4x - 3)$
- [C]  $(x + 3)$  [D]  $(x - 3)$

911. 060624a, P.I. A.N.1  
Which statement best illustrates the additive identity property?

[A]  $6 + 2 = 2 + 6$  [B]  $6 + 0 = 6$

[C]  $6 + (-6) = 0$  [D]  $6(2) = 2(6)$

912. 080024a, P.I. A.A.6  
The sum of the ages of the three Romano brothers is 63. If their ages can be represented as consecutive integers, what is the age of the middle brother?

913. 060029a, P.I. A.N.4  
The distance from Earth to the imaginary planet Med is  $1.7 \times 10^7$  miles. If a spaceship is capable of traveling 1,420 miles per hour, how many days will it take the spaceship to reach the planet Med? Round your answer to the *nearest day*.

914. 060321a, P.I. 6.S.5  
The student scores on Mrs. Frederick's mathematics test are shown on the stem-and-leaf plot below.

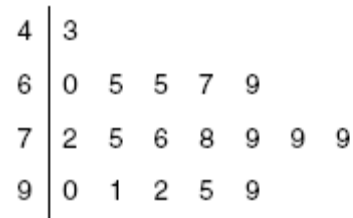

Key: 4 | 3 = 43 points

Find the median of these scores.

915. 080712a, P.I. A.N.3  
What is the sum of  $\sqrt{50}$  and  $\sqrt{8}$ ?
- [A]  $7\sqrt{2}$  [B]  $29\sqrt{2}$
- [C]  $\sqrt{58}$  [D]  $9\sqrt{2}$



916. 080726a, P.I. G.G.67  
What is the length of the line segment that joins the points whose coordinates are (4,7) and (-3,5)?
- [A]  $\sqrt{5}$  [B]  $3\sqrt{6}$   
[C]  $\sqrt{53}$  [D]  $\sqrt{193}$
917. 080623a  
The expression  $2x^2 - x^2$  is equivalent to
- [A]  $x^0$  [B]  $x^2$  [C]  $-2x^4$  [D] 2
918. 060727a, P.I. A.A.17  
What is the sum of  $\frac{3}{7n}$  and  $\frac{7}{3n}$ ?
- [A]  $\frac{10}{21n}$  [B]  $\frac{58}{21n}$  [C]  $\frac{42}{21n}$  [D]  $\frac{1}{n}$
919. 080708a, P.I. A.A.22  
In the equation  $\frac{1}{4}n + 5 = 5\frac{1}{2}$ ,  $n$  is equal to
- [A]  $\frac{1}{8}$  [B] 2 [C]  $\frac{1}{2}$  [D] 8
920. 060515a, P.I. G.G.33  
Which set could *not* represent the lengths of the sides of a triangle?
- [A] {7,9,11} [B] {2,5,9}  
[C] {3,4,5} [D] {5,10,12}
921. 010510a  
Which letter has point symmetry, but *not* line symmetry?
- [A] X [B] T [C] S [D] H
922. 060627a, P.I. A.N.3  
Expressed in simplest radical form, the product of  $\sqrt{6} \cdot \sqrt{15}$  is
- [A]  $9\sqrt{10}$  [B]  $3\sqrt{15}$   
[C]  $3\sqrt{10}$  [D]  $\sqrt{90}$
923. 060604a, P.I. A.A.12  
What is the product of  $\frac{1}{3}x^2y$  and  $\frac{1}{6}xy^3$ ?
- [A]  $\frac{1}{9}x^3y^4$  [B]  $\frac{1}{18}x^2y^3$   
[C]  $\frac{1}{2}x^2y^3$  [D]  $\frac{1}{18}x^3y^4$
924. 010116a, P.I. A.A.23  
If  $bx - 2 = K$ , then  $x$  equals
- [A]  $\frac{K}{b} + 2$  [B]  $\frac{K - 2}{b}$   
[C]  $\frac{2 - K}{b}$  [D]  $\frac{K + 2}{b}$
925. 080006a, P.I. 7.N.3  
If  $a < b$ ,  $c < d$ , and  $a$ ,  $b$ ,  $c$ , and  $d$  are all greater than 0, which expression is always true?
- [A]  $ac < bd$  [B]  $a - c + b - d = 0$   
[C]  $\frac{a}{d} > \frac{b}{c}$  [D]  $a + c > b + d$
926. 060713a, P.I. A.G.1  
If the base of a triangle is represented by  $x + 4$  and the height is represented by  $2x$ , which expression represents the area of the triangle?
- [A]  $\frac{1}{2}((x + 4) + (2x))$   
[B]  $(x + 4) + (2x)$   
[C]  $\frac{1}{2}(x + 4)(2x)$  [D]  $(x + 4)(2x)$
927. 010311a, P.I. A.N.3  
The sum of  $\sqrt{75}$  and  $\sqrt{3}$  is
- [A] 15 [B]  $6\sqrt{3}$  [C]  $\sqrt{78}$  [D] 18

928. 060014a, P.I. A.A.1  
If rain is falling at the rate of 2 inches per hour, how many inches of rain will fall in  $x$  minutes?

[A]  $\frac{60}{x}$     [B]  $\frac{x}{30}$     [C]  $\frac{30}{x}$     [D]  $2x$

929. 060530a, P.I. A.G.2  
A storage container in the shape of a right circular cylinder is shown in the accompanying diagram.

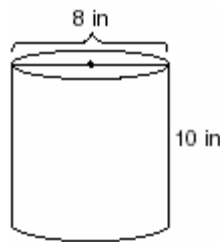

What is the volume of this container, to the nearest hundredth?

- [A]  $251.33 \text{ in}^3$     [B]  $56.55 \text{ in}^3$   
[C]  $125.66 \text{ in}^3$     [D]  $502.65 \text{ in}^3$
930. 060423a, P.I. G.G.37  
Melissa is walking around the outside of a building that is in the shape of a regular polygon. She determines that the measure of one exterior angle of the building is  $60^\circ$ . How many sides does the building have?
- [A] 6    [B] 9    [C] 3    [D] 12
931. 010723a, P.I. A2.A.8  
What is the value of  $3^0 + 3^{-2}$ ?

[A] 6    [B]  $\frac{1}{9}$     [C] 0    [D]  $1\frac{1}{9}$

932. 069930a, P.I. G.G.31  
In the accompanying diagram,  $\triangle ABC$  and  $\triangle ABD$  are isosceles triangles with  $m\angle CAB = 50$  and  $m\angle BDA = 55$ . If  $AB=AC$  and  $AB=BD$ , what is  $m\angle CBD$ ?

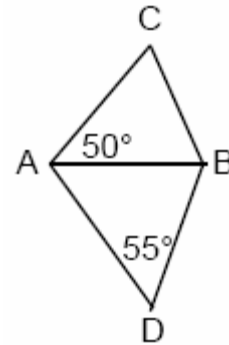

933. 060703a, P.I. A.A.6  
In his first three years coaching baseball at High Ridge High School, Coach Batty's team won 7 games the first year, 16 games the second year, and 4 games the third year. How many games does the team need to win in the fourth year so that the coach's average will be 10 wins per year?

[A] 13    [B] 3    [C] 9    [D] 10

934. 060517a, P.I. G.G.25  
The statement "If  $x$  is prime, then it is odd" is false when  $x$  equals

[A] 1    [B] 2    [C] 4    [D] 3

935. 010724a, P.I. A.A.14  
The expression  $(50x^3 - 60x^2 + 10x) \div 10x$  is equivalent to

[A]  $5x^2 - 6x$     [B]  $5x^3 - 6x^2 + x$   
[C]  $5x^2 - 6x + 1$     [D]  $5x^2 - 60x^2 + 10x$

936. 080422a, P.I. A.A.15  
For which value of  $x$  is the expression  $\frac{x-7}{x+2}$  undefined?

[A] 2    [B] -2    [C] 7    [D] 0

937. 060309a, P.I. G.G.54  
A translation moves  $P(3,5)$  to  $P'(6,1)$ . What are the coordinates of the image of point  $(-3,-5)$  under the same translation?

[A]  $(-6,-1)$                       [B]  $(-6,-9)$   
[C]  $(0,-9)$                       [D]  $(-5,-3)$

938. 080222a, P.I. A.N.1  
In the addition table for a subset of real numbers shown below, which number is the inverse of 3? Explain your answer.

$\oplus$	1	2	3	4
1	2	3	4	1
2	3	4	1	2
3	4	1	2	3
4	1	2	3	4

939. 060005a, P.I. A.A.12  
The quotient of  $-\frac{15x^8}{5x^2}$ ,  $x \neq 0$ , is

[A]  $-10x^6$                       [B]  $-10x^4$   
[C]  $-3x^4$                       [D]  $-3x^6$

940. 089933a, P.I. A.G.4  
An arch is built so that it is 6 feet wide at the base. Its shape can be represented by a parabola with the equation  $y = -2x^2 + 12x$ , where  $y$  is the height of the arch.  
a Graph the parabola from  $x = 0$  to  $x = 6$  on the grid below.

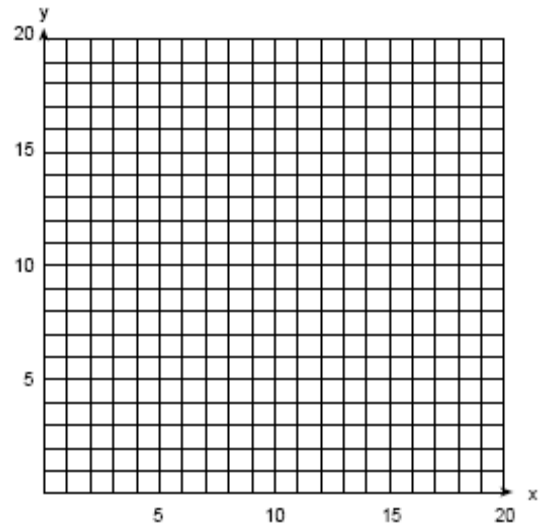

b Determine the maximum height,  $y$ , of the arch.

941. 010426a  
In the coordinate plane, the points  $(2,2)$  and  $(2,12)$  are the endpoints of a diameter of a circle. What is the length of the radius of the circle?  
[A] 5                      [B] 6                      [C] 7                      [D] 10

942. 089915a, P.I. G.G.45  
In the accompanying diagram of equilateral triangle  $ABC$ ,  $DE = 5$  and  $\overline{DE} \parallel \overline{AB}$ .

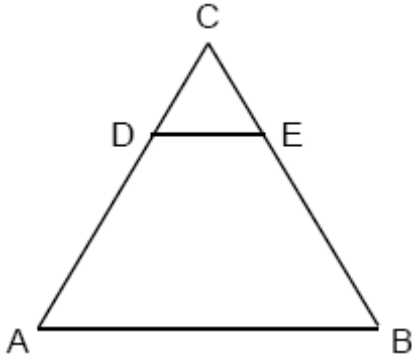

- If  $AB$  is three times as long as  $DE$ , what is the perimeter of quadrilateral  $ABED$ ?
- [A] 35    [B] 40    [C] 20    [D] 30
943. 080735a, P.I. G.G.39  
In rhombus  $ABCD$ , the measure, in inches, of  $\overline{AB}$  is  $3x + 2$  and  $\overline{BC}$  is  $x + 12$ . Find the number of inches in the length of  $\overline{DC}$ .
944. 069927a  
The dimensions of a brick, in inches, are 2 by 4 by 8. How many such bricks are needed to have a total volume of exactly 1 cubic foot?
945. 060323a, P.I. A.A.22  
Solve for  $m$ :  $0.6m + 3 = 2m + 0.2$
946. 060119a  
What is the total number of points of intersection in the graphs of the equations  $x^2 + y^2 = 16$  and  $y = 4$ ?
- [A] 1    [B] 0    [C] 2    [D] 3
947. 069901a, P.I. A.S.20  
A fair coin is thrown in the air four times. If the coin lands with the head up on the first three tosses, what is the probability that the coin will land with the head up on the fourth toss?
- [A]  $\frac{1}{8}$     [B] 0    [C]  $\frac{1}{2}$     [D]  $\frac{1}{16}$
948. 080417a, P.I. A.A.32  
If the value of dependent variable  $y$  increases as the value of independent variable  $x$  increases, the graph of this relationship could be a
- [A] horizontal line  
[B] line with a negative slope  
[C] line with a positive slope  
[D] vertical line
949. 080025a, P.I. A2.S.11  
Alan, Becky, Jesus, and Mariah are four students in the chess club. If two of these students will be selected to represent the school at a national convention, how many combinations of two students are possible?
950. 060428a, P.I. A.A.37  
The line  $3x - 2y = 12$  has
- [A] a slope of  $-\frac{3}{2}$  and a  $y$ -intercept of 6  
[B] a slope of -3 and a  $y$ -intercept of -6  
[C] a slope of 3 and a  $y$ -intercept of -2  
[D] a slope of  $\frac{3}{2}$  and a  $y$ -intercept of -6

951. 060012a, P.I. A.A.37  
The accompanying figure shows the graph of the equation  $x = 5$ .

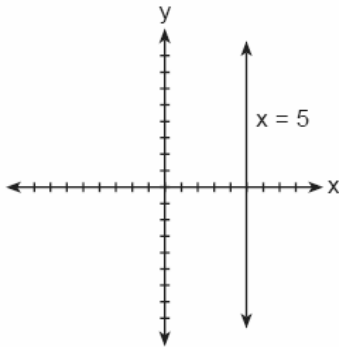

What is the slope of the line  $x = 5$ ?

- [A] 5    [B] -5    [C] undefined    [D] 0
952. 010118a, P.I. 6.S.5  
From January 3 to January 7, Buffalo recorded the following daily high temperatures:  $5^\circ$ ,  $7^\circ$ ,  $6^\circ$ ,  $5^\circ$ , and  $7^\circ$ . Which statement about the temperatures is true?
- [A] mean = median    [B] mean = mode  
[C] median = mode    [D] mean < median
953. 010730a, P.I. A.N.1

The multiplicative inverse of  $-\frac{1}{3}$  is

- [A] 3    [B]  $-\frac{1}{3}$     [C]  $\frac{1}{3}$     [D] -3

954. 060135a, P.I. G.G.54  
Triangle  $SUN$  has coordinates  $S(0,6)$ ,  $U(3,5)$ , and  $N(3,0)$ . On the accompanying grid, draw and label  $\triangle SUN$ . Then, graph and state the coordinates of  $\triangle S'U'N'$ , the image of  $\triangle SUN$  after a reflection in the  $y$ -axis.

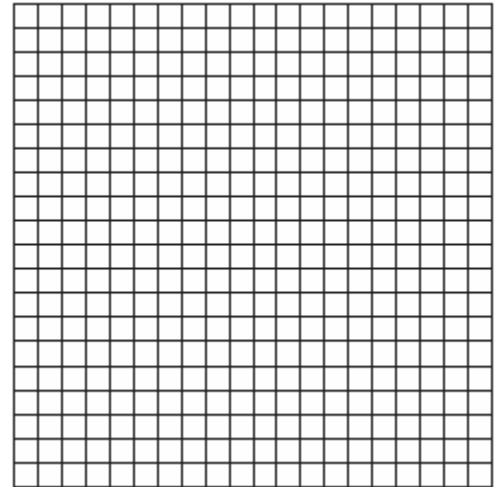

955. 080737a, P.I. G.G.22  
In the diagram below, town  $C$  lies on straight road  $p$ . Sketch the points that are 6 miles from town  $C$ . Then sketch the points that are 3 miles from road  $p$ . How many points satisfy both conditions?



956. 080719a, P.I. G.G.56

In the accompanying diagram,  $\triangle A'B'C'$  is the image of  $\triangle ABC$  and  $\triangle A'B'C' \cong \triangle ABC$ .

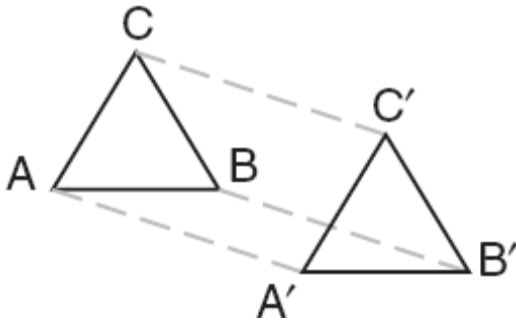

Which type of transformation is shown in the diagram?

- [A] dilation                      [B] rotation  
[C] line reflection              [D] translation

957. 080639a

Manuel plans to install a fence around the perimeter of his yard. His yard is shaped like a square and has an area of 40,000 square feet. The company that he hires charges \$2.50 per foot for the fencing and \$50.00 for the installation fee. What will be the cost of the fence, in dollars?

958. 060609a, P.I. 7.N.3

Which list is in order from smallest value to largest value?

- [A]  $3.1, \pi, \frac{22}{7}, \sqrt{10}$       [B]  $\pi, \frac{22}{7}, 3.1, \sqrt{10}$   
[C]  $3.1, \frac{22}{7}, \pi, \sqrt{10}$       [D]  $\sqrt{10}, \frac{22}{7}, \pi, 3.1$

959. 010831a

The circumference of a circle measures  $22\pi$  units. Find the number of square units in the area of the circle. Express your answer in terms of  $\pi$ .

960. 069926a, P.I. 8.G.13

During a 45-minute lunch period, Albert (A) went running and Bill (B) walked for exercise. Their times and distances are shown in the accompanying graph. How much faster was Albert running than Bill was walking, in miles per hour?

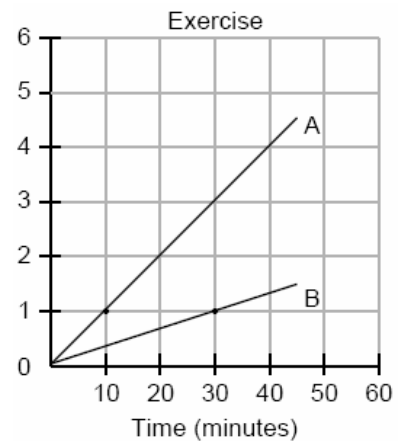

961. 060227a, P.I. G.G.33

The plot of land illustrated in the accompanying diagram has a perimeter of 34 yards. Find the length, in yards, of *each* side of the figure. Could these measures actually represent the measures of the sides of a triangle? Explain your answer.

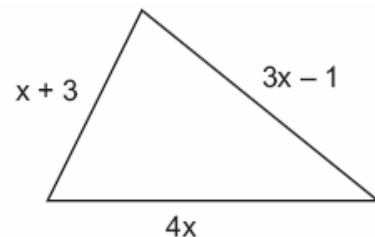

962. 010829a, P.I. A2.S.10

What is the total number of different seven-letter arrangements that can be formed using the letters in the word "MILLION"?

- [A] 210    [B] 1,260    [C] 2,520    [D] 30