

JMAP REGENTS BY DATE

NY Geometry Regents Exam Questions
from Spring 2014 to January 2026 Sorted by Date

www.jmap.org

2024 Geometry Sample Items

1 Triangles ABC and DEF are graphed on the set of axes below.

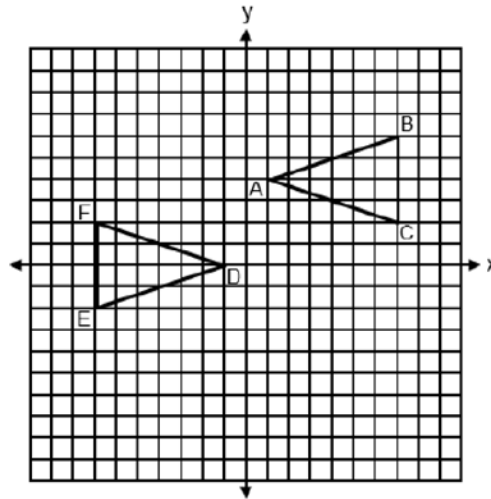

Which sequence of rigid motions maps $\triangle ABC$ onto $\triangle DEF$?

- | | |
|--|--|
| 1) A reflection over $y = -x + 2$. | 3) A translation 2 units left followed by a reflection over the x -axis. |
| 2) A point reflection through $(0, 2)$. | 4) A translation 4 units down followed by a reflection over the y -axis. |

2 In right triangle ABC below, $m\angle C = 90^\circ$, $m\angle B = 30^\circ$, and $CB = 6\sqrt{3}$.

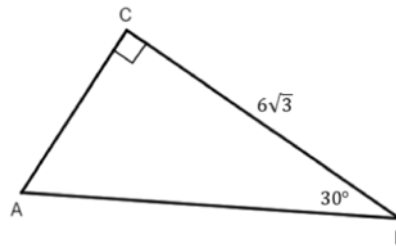

The length of \overline{AB} is

- | | |
|----------------|-----------------|
| 1) $3\sqrt{3}$ | 3) 12 |
| 2) 9 | 4) $12\sqrt{3}$ |

- 5 A triangle with vertices at $(-2,3)$, $(3,6)$, and $(2,1)$, is graphed on the set of axes below. A horizontal stretch of scale factor 2 with respect to $x = 0$, is represented by $(x,y) \rightarrow (2x,y)$. Graph the image of this triangle, after the horizontal stretch on the same set of axes.

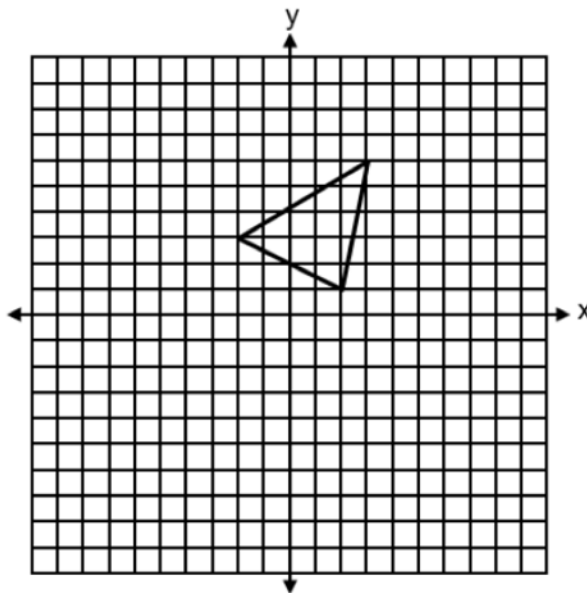

- 6 Triangle XYZ is shown below. Using a compass and straightedge, construct the circumcenter of $\triangle XYZ$.

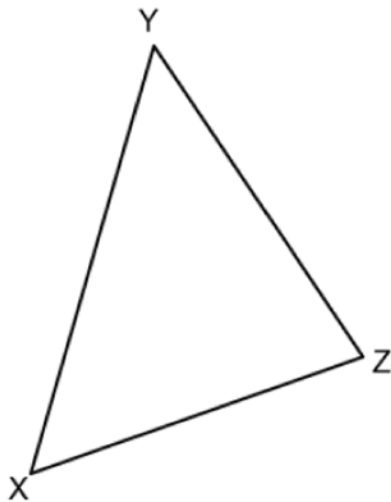

- 7 In the diagram below, $\triangle ABC \sim \triangle DEF$.

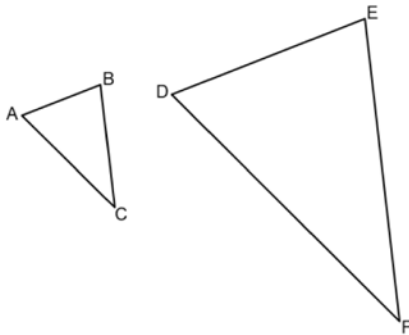

If $AB = 4$, $BC = x - 1$, $DE = x + 3$, and $EF = 15$, determine and state the length of \overline{DE} .

- 8 Hexagon $ABCDEF$ with coordinates at $A(0,6)$, $B(3,3)$, $C(3,1)$, $D(0,-2)$, $E(-3,1)$, and $F(-3,3)$ is graphed on the set of axes below.

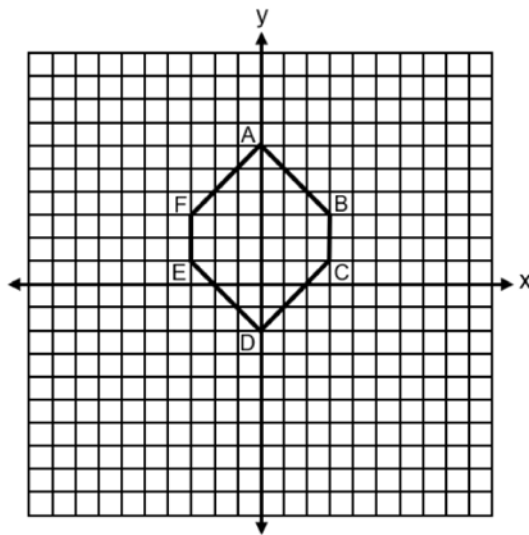

Determine and state the perimeter of $ABCDEF$ in simplest radical form.

0625geo

- 1 The perimeter of a triangle is 18. What is the perimeter of a similar triangle after a dilation with scale factor of 3?

- 1) 6
- 2) 18
- 3) 54
- 4) 162

- 2 The Washington Monument, shown below, is in Washington, D.C. At a point on the ground 200 feet from the center of the base of the monument, the angle of elevation to the top of the monument is 70.19° .

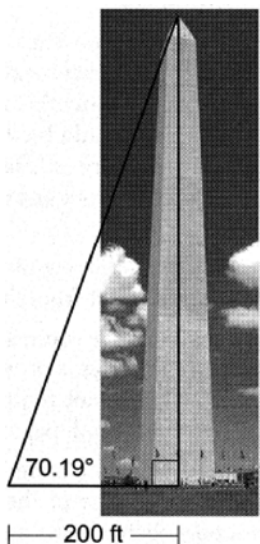

What is the height of the monument, to the *nearest foot*?

- 1) 188
- 2) 213
- 3) 555
- 4) 590

- 3 On the set of axes below, $\triangle EQA$ and $\triangle SUL$ are graphed.

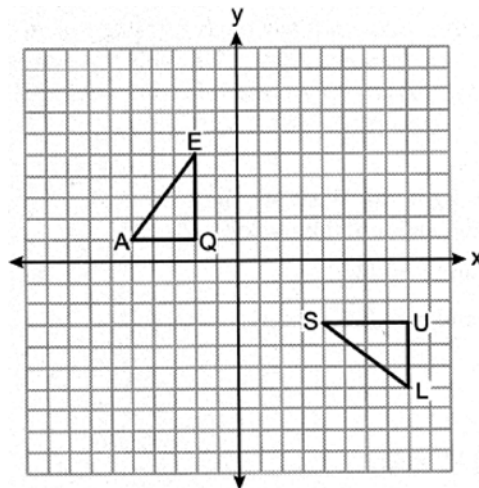

Which sequence of transformations shows that $\triangle EQA \cong \triangle SUL$?

- 1) Rotate $\triangle EQA$ 90° counterclockwise about the origin and then translate 9 units right and 1 unit down.
 - 2) Rotate $\triangle EQA$ 90° counterclockwise about the origin and then reflect over the line $x = 4$.
 - 3) Reflect $\triangle EQA$ over the x -axis and then rotate clockwise about the origin.
 - 4) Translate $\triangle EQA$ 10 units right and then reflect over the line $x = -1$.
- 4 If two sides of a triangle have lengths of 2 and 8, the length of the third side could be
- 1) 10
 - 2) 7
 - 3) 6
 - 4) 4
- 5 A regular octagon is rotated about its center. Which angle measure will carry the octagon onto itself?
- 1) 36°
 - 2) 90°
 - 3) 144°
 - 4) 160°

- 6 An equation of a circle is $x^2 + y^2 - 6x + 2y = 14$.
 What are the coordinates of the center and the length of the radius of this circle?
- 1) $(-3, 1)$ and $r = 5$
 - 2) $(3, -1)$ and $r = 5$
 - 3) $(-3, 1)$ and $r = \sqrt{24}$
 - 4) $(3, -1)$ and $r = \sqrt{24}$

- 7 In $\triangle HSF$ below, $m\angle S = 90^\circ$, $HF = 30$, and $FS = 23$.

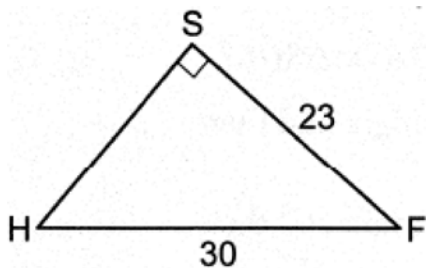

What is $m\angle F$, to the nearest degree?

- 1) 53°
 - 2) 50°
 - 3) 40°
 - 4) 37°
- 8 In $\triangle CAB$ below, midsegments \overline{DE} , \overline{EF} , and \overline{FD} are drawn.

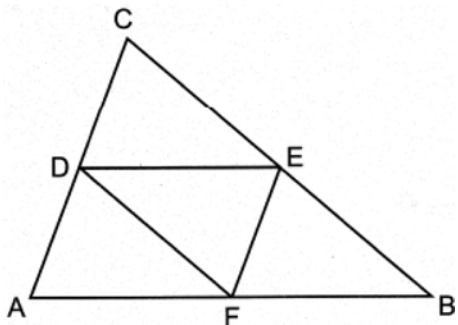

If $CA = 14$, $CB = 20$, and $FB = 9$, what is the perimeter of quadrilateral $DEFA$?

- 1) 26
- 2) 32
- 3) 44
- 4) 52

- 9 A candle can be modeled by a pyramid with a square base, as shown below. The height of the candle is 10 cm, and each side of the base measures 6 cm.

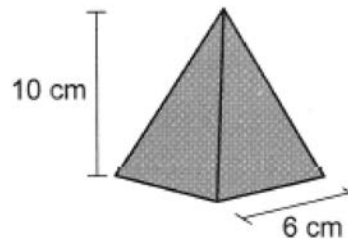

If the candle wax burns at a rate of 3.5 cubic centimeters per hour, what is the approximate number of hours this candle could burn?

- 1) 103
- 2) 51
- 3) 34
- 4) 11

- 10 In the diagram below, tangent \overline{SR} and secant \overline{STU} are drawn to circle O from external point S .

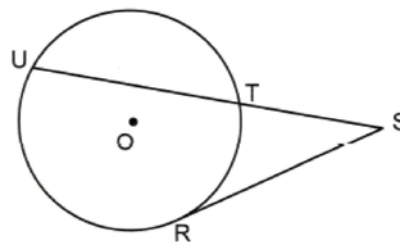

If $\widehat{TU} \cong \widehat{RU}$ and $m\widehat{TR} = 68^\circ$, what is $m\angle S$?

- 1) 22°
- 2) 34°
- 3) 39°
- 4) 78°

- 11 Triangle RST has $m\angle S = 33^\circ$, $RS = 7$, and $ST = 12$. What is the area of $\triangle RST$, to the nearest tenth?

- 1) 22.9
- 2) 27.3
- 3) 35.2
- 4) 45.7

- 12 Triangle ABC , with vertices whose coordinates are $A(-3,-2)$, $B(-1,2)$, and $C(4,1)$, is graphed on the set of axes below.

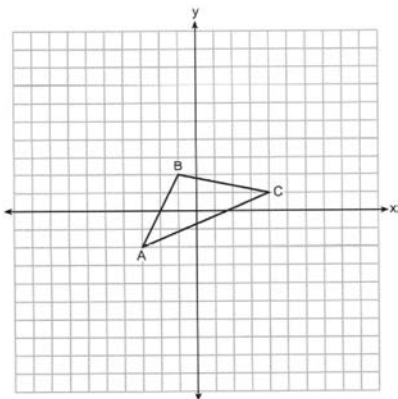

Triangle $A'B'C'$, whose vertices have coordinates $A'(-6,-2)$, $B'(-2,2)$, and $C'(8,1)$, is the image of $\triangle ABC$. The transformation that maps $\triangle ABC$ onto $\triangle A'B'C'$ is a

- 1) dilation
 - 2) translation
 - 3) vertical stretch
 - 4) horizontal stretch
- 13 Which equation represents a line parallel to the line represented $y = 4x + 6$ and passing through the point $(-3, 2)$?
- 1) $y - 2 = 4(x + 3)$
 - 2) $y + 3 = 4(x - 2)$
 - 3) $y - 2 = -\frac{1}{4}(x + 3)$
 - 4) $y + 3 = -\frac{1}{4}(x - 2)$
- 14 Which two-dimensional figure is always formed when a plane intersects a right cylinder perpendicular to its base?
- 1) circle
 - 2) triangle
 - 3) rhombus
 - 4) rectangle

- 15 In $\triangle KMP$ below, \overline{CE} is drawn parallel to \overline{MP} .

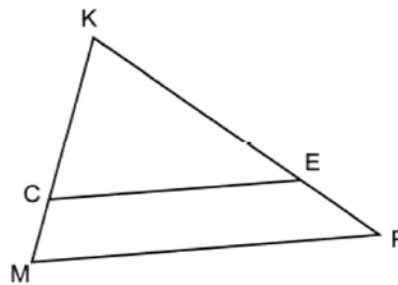

If $KC = 8$, $CM = 3$, and $CE = 12$, what is the length of \overline{MP} ?

- 1) 24
 - 2) 16.5
 - 3) 15
 - 4) 4.5
- 16 A parallelogram must be a rectangle if its diagonals
- 1) are perpendicular
 - 2) bisect each other
 - 3) bisect its angles
 - 4) are congruent
- 17 Point O divides \overline{COA} such that $CO:OA = 1:4$. If C has coordinates $(-2, -9)$ and A has coordinates $(3, 6)$, the coordinates of O are
- 1) $(2, 3)$
 - 2) $(1, 0)$
 - 3) $(0, -3)$
 - 4) $(-1, -6)$
- 18 A spherical balloon is fully inflated with helium to a diameter of 1.7 feet. If helium costs \$0.80 per cubic foot, what is the cost to completely fill the balloon with helium?
- 1) \$2.06
 - 2) \$2.42
 - 3) \$3.22
 - 4) \$16.46

- 19 In right triangle \overline{ABD} below, altitude \overline{BC} is drawn to hypotenuse \overline{AD} , $AC = 2.5$, and $CD = 4.3$.

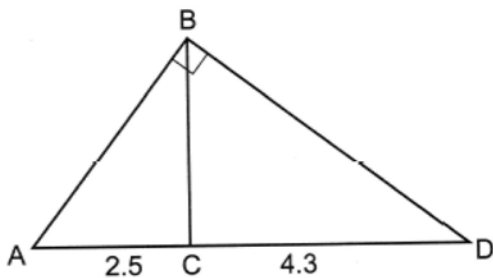

What is the length of \overline{BA} , to the nearest tenth?

- 1) 3.3
 - 2) 3.4
 - 3) 4.1
 - 4) 5.4
- 20 Trapezoid $ZOYD$ has parallel sides \overline{ZO} and \overline{DY} . If $m\angle Z = 141^\circ$ and $m\angle Y = 73^\circ$, what is $m\angle D$?
- 1) 39°
 - 2) 73°
 - 3) 107°
 - 4) 141°
- 21 Triangle ABC is translated 5 units to the left and 2 units up to map onto $\triangle PQR$. Which statement is *not* always true?
- 1) $\triangle PQR \cong \triangle ABC$
 - 2) $\angle A \cong \angle Q$
 - 3) $BQ = \sqrt{29}$
 - 4) $RQ = CB$

- 22 In the diagram below, congruent triangles PEN and PAL are drawn.

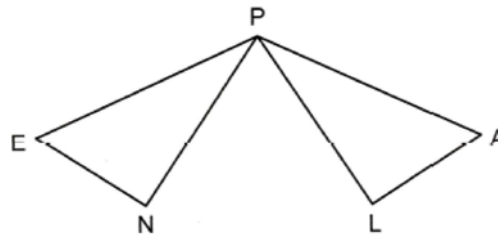

Which rigid motion maps $\triangle PEN$ onto $\triangle PAL$?

- 1) a point reflection of $\triangle PEN$ through P
 - 2) a reflection of $\triangle PEN$ over the angle bisector of $\angle EPA$
 - 3) a rotation of $\triangle PEN$ about point P , mapping \overline{PE} onto \overline{PA}
 - 4) a translation of $\triangle PEN$ along \overline{EA} , mapping point E onto A
- 23 A cone has a height of 8 inches and volume of 75.4 cubic inches. What is the diameter of the cone, to the nearest inch?
- 1) 9
 - 2) 2
 - 3) 3
 - 4) 6
- 24 The line represented by the equation $5x - 2y = 10$ is transformed by a dilation centered at $(2,0)$ with a scale factor of 2. The image of the line
- 1) is the original line
 - 2) passes through the point $(4,0)$
 - 3) passes through the point $(0,-10)$
 - 4) is perpendicular to the original line
- 25 In the year 2020, the village of Depew, New York had an area of 5.1 square miles and a population of 15,069. In the same year, the village of Lancaster, New York had an area of 2.7 square miles and a population of 10,087. Which village had the larger population density in 2020? Justify your answer.

- 26 In $\triangle ABC$ below, \overline{AC} is extended through C to D , $m\angle A = (3x - 22)^\circ$, $m\angle B = (4x - 18)^\circ$, and $m\angle BCD = (6x - 23)^\circ$.

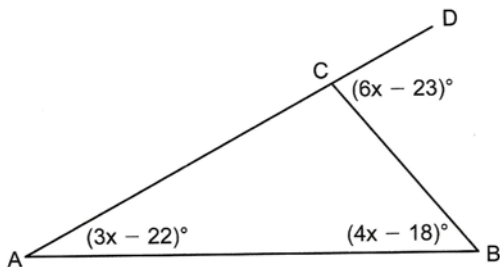

Determine and state $m\angle ACB$.

- 27 Parallelogram $ABCD$ is shown below. Using a compass and straightedge, construct the altitude from point A to side DC . [Leave all construction marks.]

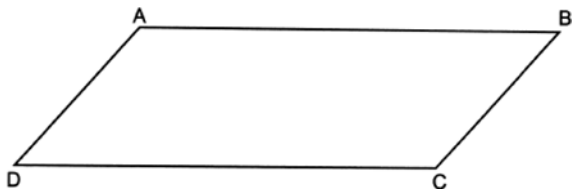

- 28 Quadrilateral $QUAD$ is graphed on the set of axes below.

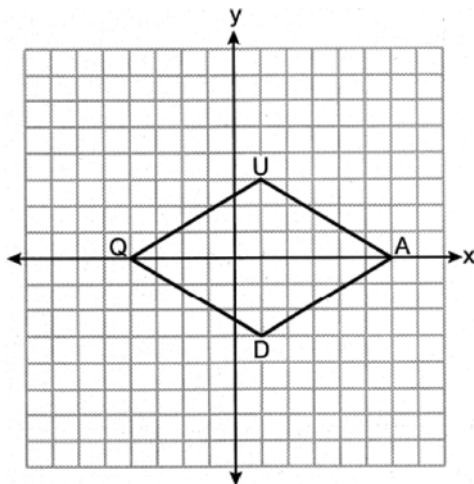

Determine and state the area of quadrilateral $QUAD$.

- 29 In a right triangle, the acute angles have the relationship $\sin(3x - 7)^\circ = \cos(x + 1)^\circ$. Determine and state the value of x .

- 30 In circle A below, $m\angle BAM = 36^\circ$.

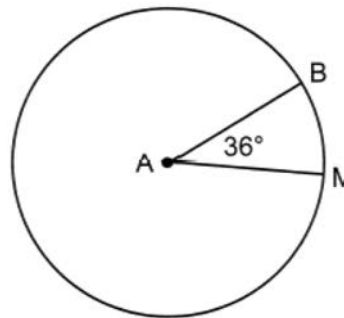

If $AB = 20$, determine and state the length of \widehat{MB} . [Leave your answer in terms of π .]

- 31 In triangles ANT and ELM below, $AN = 6$, $NT = 5.6$, $TA = 4$, $EL = 9$, $LM = 8.4$, and $ME = 6$.

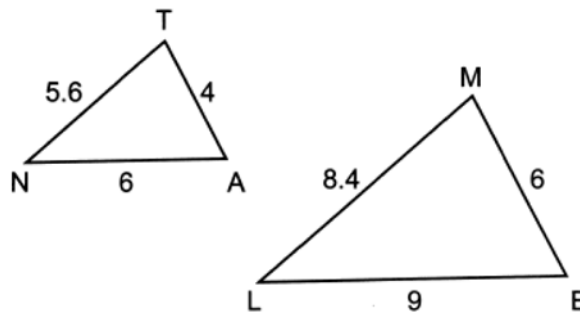

Explain why $\triangle ANT \sim \triangle ELM$.

- 32 A store sells colored craft sand in the three different containers below.
 Container 1: A square prism with a base length of 4 inches and a height of 7.5 inches.
 Container 2: A cylinder with a diameter of 5 inches and a height of 6 inches.
 Container 3: A cone with a diameter of 7.5 inches and a height of 8.5 inches.
 If the containers are filled to the top, which container will hold the most sand? Justify your answer.

- 33 Quadrilateral *MIKE* has vertices with coordinates $M(-1,-3)$, $I(-3,3)$, $K(5,4)$, and $E(7,-2)$. Prove *MIKE* is a parallelogram, and prove *MIKE* is *not* a rhombus. [The use of the set of axes below is optional.]

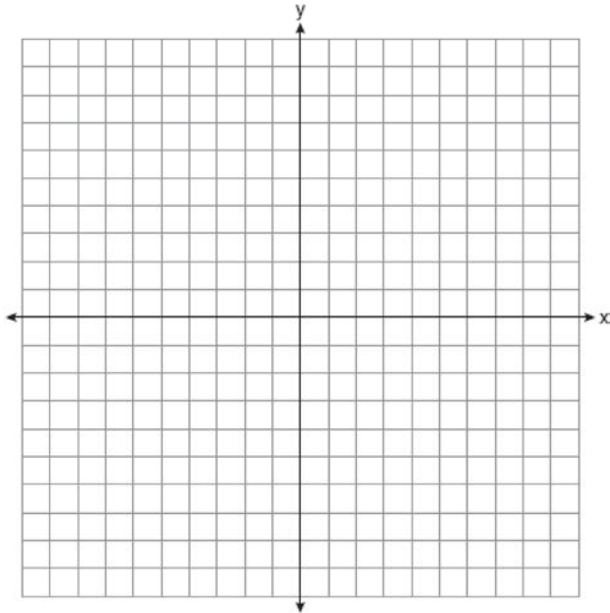

- 34 A park ranger needs to secure two different trees with wire. A wire is to be attached from a stake in the ground to each tree. The wire is attached at two different heights and two different angles of elevation, as indicated in the model below.

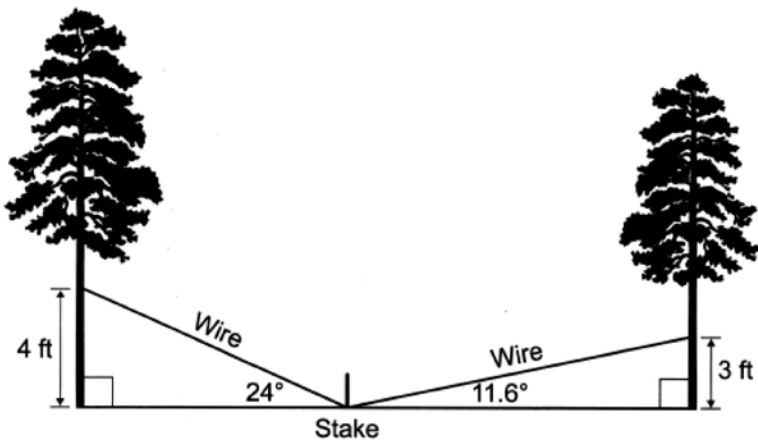

The park ranger has 20 feet of wire. Does the park ranger have enough wire to secure both trees? Justify your answer.

35 Given: Quadrilateral $CARI$ with $\overline{CA} \cong \overline{RI}$ and $\overline{CI} \cong \overline{RA}$, and \overline{AEI} and \overline{LEH} are drawn

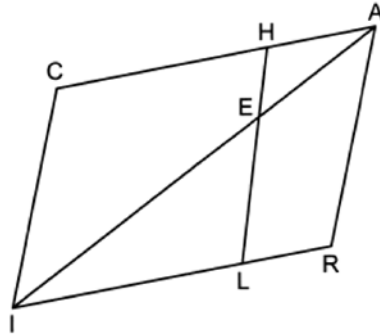

Prove: $HA \bullet EL = LI \bullet EH$

0825geo

- 1 An equilateral triangle is continuously rotated around one of its altitudes. The three-dimensional object formed is a

- 1) cone
- 2) sphere
- 3) cylinder
- 4) pyramid

- 2 On the set of axes below, quadrilateral $BDGF$ is rotated 90 degrees clockwise about the origin and then reflected over the y -axis. The image of quadrilateral $BDGF$ is quadrilateral $MQSP$.

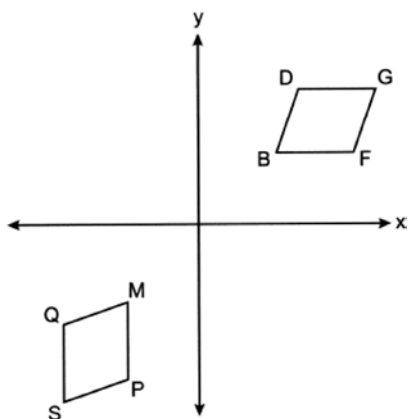

Side \overline{BD} will always map onto

- 1) \overline{MP}
- 2) \overline{PS}
- 3) \overline{MQ}
- 4) \overline{SQ}

- 3 In right triangle JOE , hypotenuse $JO = 31.8$ and $m\angle J = 38^\circ$. To the nearest tenth, the length of \overline{EJ} is

- 1) 19.6
- 2) 25.1
- 3) 40.4
- 4) 51.7

- 4 The hemisphere below has a radius of 8 cm.

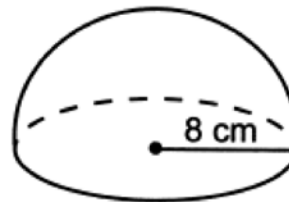

To the nearest cubic centimeter, the volume of the hemisphere is

- 1) 201
- 2) 268
- 3) 1072
- 4) 2145

- 5 In parallelogram $ABCD$, diagonals \overline{AC} and \overline{BD} intersect at E . Which information is sufficient to prove $ABCD$ is a rhombus?

- 1) $\overline{AE} \cong \overline{EC}$
- 2) $\overline{AC} \cong \overline{BD}$
- 3) $\overline{AB} \perp \overline{BC}$
- 4) $\overline{AC} \perp \overline{BD}$

- 6 Trapezoid $JOSH$, shown below, has non-parallel sides \overline{JH} and \overline{OS} , $m\angle J = 65^\circ$, $m\angle O = 30^\circ$, $m\angle OSA = 80^\circ$, and $m\angle SHU = 60^\circ$.

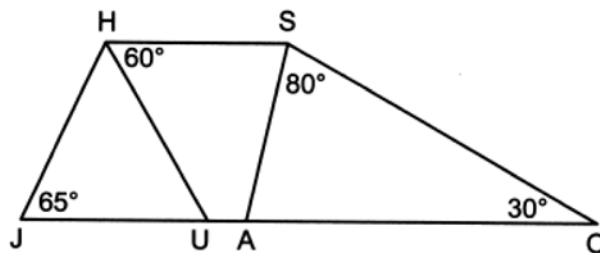

What is $m\angle HSA$?

- 1) 55°
- 2) 60°
- 3) 65°
- 4) 70°

- 7 In $\triangle ABC$ below, points D and E are on \overline{AB} and \overline{CB} , respectively, such that $\overline{DE} \parallel \overline{AC}$.

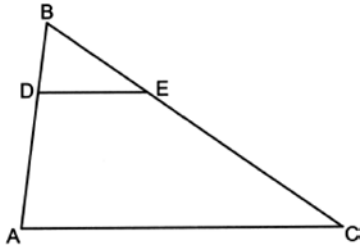

If $\overline{AD} = 8$, $\overline{DB} = 4$, and $\overline{DE} = 6$, what is the length of \overline{AC} ?

- 1) 24
 - 2) 18
 - 3) 12
 - 4) 10
- 8 On the set of axes below, circle C has a center with coordinates $(2, -1)$.

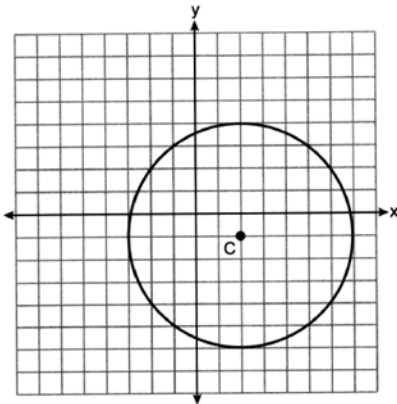

Which equation represents circle C ?

- 1) $(x - 2)^2 + (y + 1)^2 = 25$
- 2) $(x - 2)^2 + (y + 1)^2 = 16$
- 3) $(x + 2)^2 + (y - 1)^2 = 25$
- 4) $(x + 2)^2 + (y - 1)^2 = 16$

- 9 On the set of axes below, $\triangle D'E'F'$ is the image of $\triangle DEF$.

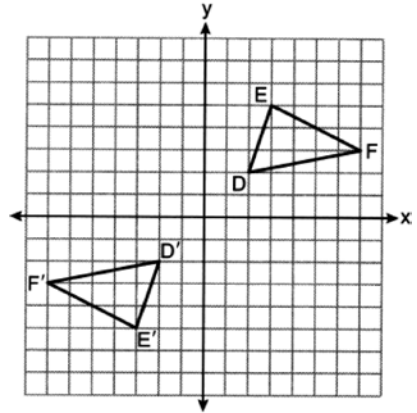

A transformation that maps $\triangle DEF$ onto $\triangle D'E'F'$ is a

- 1) reflection over the line $y = x$
 - 2) reflection over the line $y = -x$
 - 3) point reflection through the origin
 - 4) translation 4 units left and 4 units down
- 10 In circle O below, secants \overline{PCA} and \overline{PDB} are drawn from external point P .

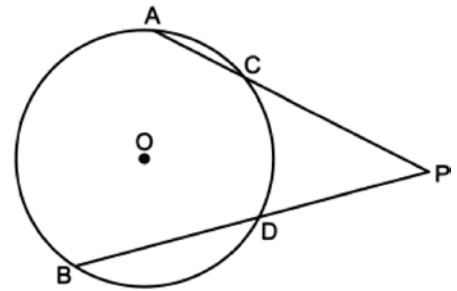

If $\overline{PA} = 17$, $\overline{PD} = 10$, and $\overline{BD} = 12$, what is the length of \overline{PC} , to the nearest tenth?

- 1) 7.1
- 2) 7.7
- 3) 12.9
- 4) 14.2

- 11 In the diagram below, $\overline{CD} \parallel \overline{AB}$, and \overline{CB} bisects $\angle ABD$.

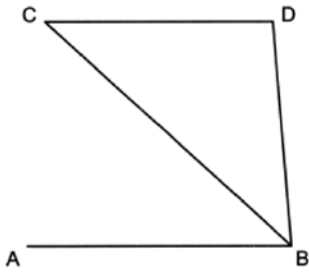

Which statement must be true?

- 1) $\overline{CD} \cong \overline{AB}$
 - 2) $\overline{AB} \cong \overline{BD}$
 - 3) $\triangle CDB$ is a right triangle
 - 4) $\triangle CDB$ is an isosceles triangle
- 12 Line h is represented by the equation $y = \frac{2}{3}x - 4$.

Which equation represents the line that is perpendicular to line h and passes through the point $(6, 1)$?

- 1) $y - 1 = \frac{2}{3}(x - 6)$
- 2) $y + 1 = \frac{2}{3}(x + 6)$
- 3) $y - 1 = -\frac{3}{2}(x - 6)$
- 4) $y + 1 = -\frac{3}{2}(x + 6)$

- 13 A wooden toy block can be modeled by a pyramid with a square base, as shown below. The height of the block is 17.4 cm and the square base has a side length of 8.2 cm.

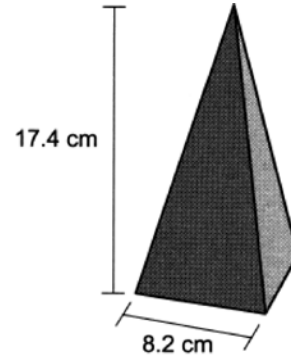

The block is made of solid oak, which has a density of 0.77 g/cm^3 . What is the mass of the block, to the nearest gram?

- 1) 300
 - 2) 506
 - 3) 637
 - 4) 901
- 14 In $\triangle ABC$ below, midsegment \overline{DE} is drawn.

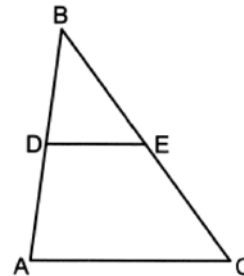

If $\overline{DE} = x + 3$ and $\overline{AC} = 3x - 5$, what is the length of \overline{DE} ?

- 1) 28
- 2) 14
- 3) 7
- 4) 4

- 15 Triangle DUG is an isosceles right triangle with the right angle at G . If $DU = 10\sqrt{2}$, what is the length of GU ?
- 1) 5
 - 2) $5\sqrt{2}$
 - 3) 10
 - 4) $10\sqrt{2}$

- 16 In $\triangle RST$ below, $RS = 9$ cm, $RT = 8$ cm, and $m\angle TRS = 55^\circ$.

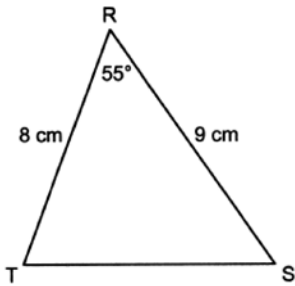

What is the area of $\triangle RST$, to the nearest square centimeter?

- 1) 59
- 2) 36
- 3) 29
- 4) 21

- 17 Triangle ABC is dilated by a scale factor of 2 to map onto its image, $\triangle RST$, on the set of axes below.

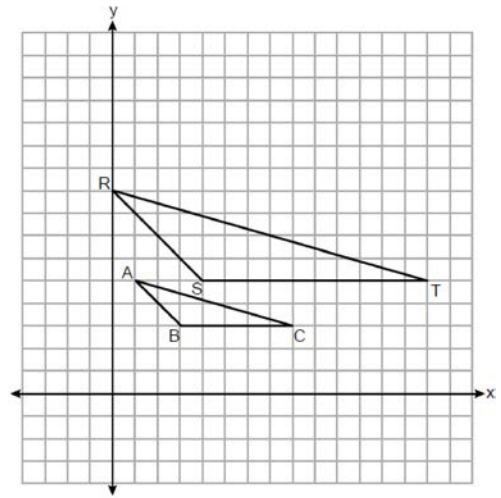

What are the coordinates of the center of this dilation?

- 1) $(1, -1)$
 - 2) $(2, 1)$
 - 3) $(3, 3)$
 - 4) $(0, 0)$
- 18 What is the perimeter of $\triangle ABC$, where the vertices have coordinates $A(-2, 3)$, $B(-2, -1)$, and $C(6, -1)$?
- 1) 16
 - 2) 92
 - 3) $16\sqrt{5}$
 - 4) $12 + 4\sqrt{5}$

- 19 In the diagram below, \overline{GT} and \overline{PF} intersect at E , and $\angle P \cong \angle F$.

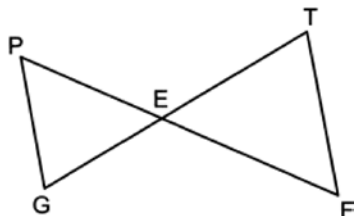

Which equation is always true?

- 1) $\frac{PE}{FE} = \frac{FT}{PG}$
 - 2) $\frac{GE}{TE} = \frac{FT}{PG}$
 - 3) $\frac{PE}{GE} = \frac{TE}{FE}$
 - 4) $\frac{PE}{FE} = \frac{PG}{FT}$
- 20 A section of sidewalk in the shape of a rectangular prism is being replaced. The sidewalk is 10 feet long, 4 feet wide, and 4 inches deep. A brand of concrete mix yields 0.6 cubic foot of concrete per bag. What is the minimum number of bags of concrete mix that must be purchased to completely replace this sidewalk?
- 1) 22
 - 2) 23
 - 3) 26
 - 4) 27
- 21 The line $4x - 6y = 24$ is transformed by a dilation of scale factor 3 centered at the origin. Which equation represents the image of the line after this dilation?
- 1) $y = \frac{2}{3}x - 12$
 - 2) $y = \frac{2}{3}x - 4$
 - 3) $y = 2x - 12$
 - 4) $y = 2x - 4$

- 22 A rhombus is graphed on the set of axes below.

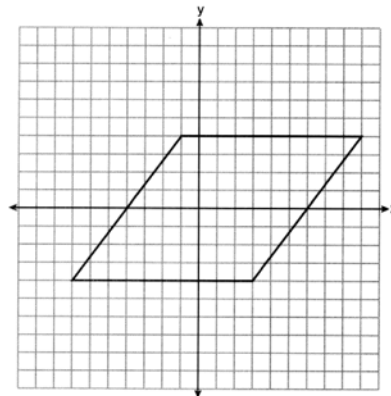

Which transformation does *not* carry the rhombus onto itself?

- 1) a rotation of 180° about the origin
 - 2) a rotation of 180° about point $(1, 0)$
 - 3) a reflection over the line $y = \frac{1}{2}x - \frac{1}{2}$
 - 4) a reflection over the line $y = -2x + 2$
- 23 In right triangle HAY below, altitude \overline{AL} is drawn to hypotenuse \overline{HY} .

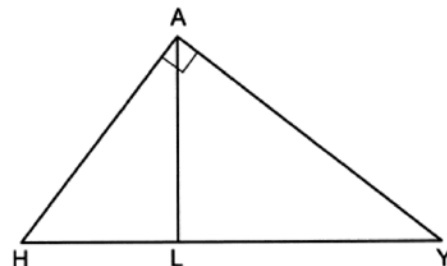

If $HY = 25$ and $YA = 20$, the length of \overline{AL} is

- 1) 9
- 2) 12
- 3) 15
- 4) 16

- 24 Square $ABCD$ has an area of 36. If the square is dilated by a scale factor of $\frac{1}{2}$ centered at A , what is the area of its image?
- 1) 9
 - 2) 18
 - 3) 72
 - 4) 144

- 25 Triangle $D'A'N'$ is the image of $\triangle DAN$ after a translation. Explain why $\triangle D'A'N'$ must be congruent to $\triangle DAN$.

- 26 The table below lists five metals and their densities.

| Metal | Density (g/cm ³) |
|--------|------------------------------|
| Zinc | 7.14 |
| Tin | 7.31 |
| Iron | 7.86 |
| Copper | 8.96 |
| Silver | 10.5 |

A solid metal cube has an edge length of 5 cm and a mass of 982.5 grams. Using the table above, determine and state the type of metal from which this cube is made.

- 27 The endpoints of \overline{CS} are $C(-3, 1)$ and $S(7, 6)$. Determine and state the coordinates of point A such that the ratio of $CA:AS$ is 3:2. [The use of the set of axes below is optional.]

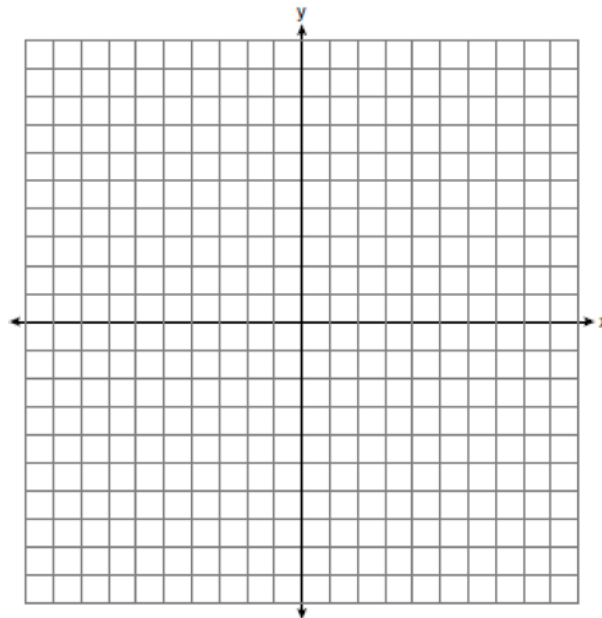

- 28 The ramp shown in the diagram below has an angle of elevation of 4.8° . The ramp is built to a landing 0.6 m above the ground.

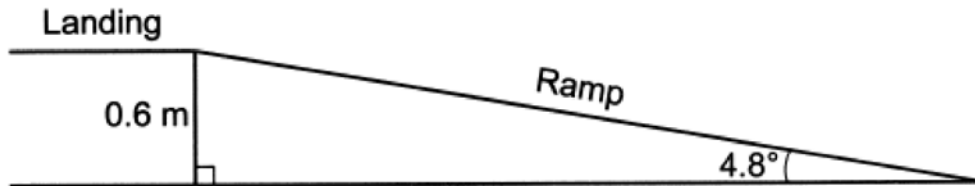

Determine and state the length of the ramp, to the *nearest tenth of a meter*.

- 29 Angle KML is the vertex angle of isosceles triangle KLM below. Side LM is extended through vertex M to point N .

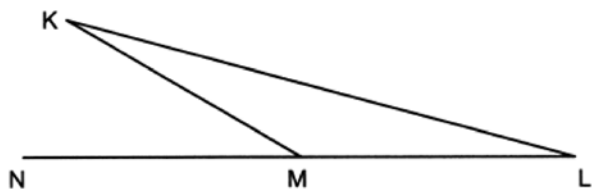

If $m\angle K = 15^\circ$, determine and state $m\angle KMN$.

- 30 In the diagram below of circle L , the area of the shaded sector KLM is 7.5π and $LK = 5$.

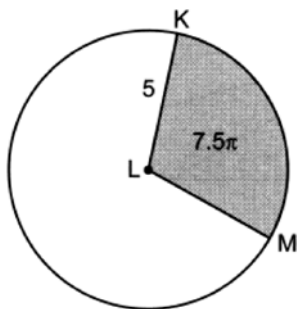

Determine and state the degree measure of angle KLM , the central angle of the shaded sector.

- 31 Using a compass and straightedge, construct the image of point A after a reflection over \overline{BC} . [Leave all construction marks.]

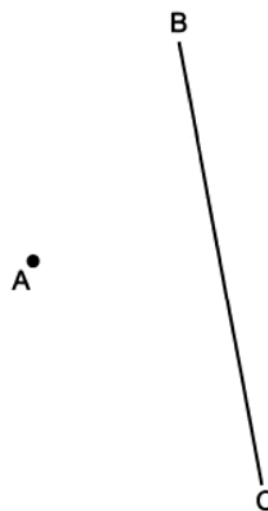

- 32 Joan wants to fill an empty 75-liter fish tank with water. She uses a cylindrical bucket with a diameter of 20 cm. Determine and state the maximum number of buckets of water, filled to an exact height of 26 cm, Joan can put into the fish tank before it overflows. [$1000 \text{ cm}^3 = 1 \text{ liter}$]

33

As modeled in the diagram below, two cables are attached from a point on a tree 12 feet above the ground. The longer cable is anchored on the ground 3 feet farther from the tree than the shorter cable is anchored. The angle of elevation between the shorter cable and the ground is 50° .

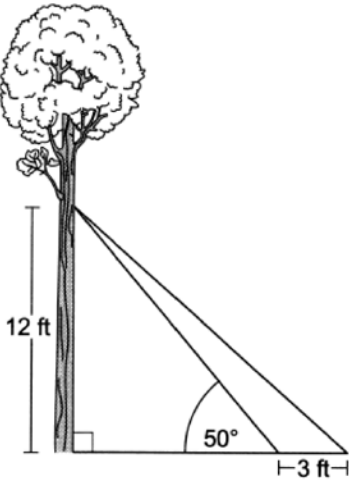

Determine and state, to the *nearest foot*, the distance from the base of the tree to the point where the longer cable is attached to the ground. Determine and state, to the *nearest degree*, the angle of elevation between the longer cable and the ground.

34 Quadrilateral $READ$ has vertices with coordinates $R(-1,3)$, $E(2,7)$, $A(10,1)$, and $D(7,-3)$. Prove $READ$ is a rectangle. [The use of the set of axes below is optional.]

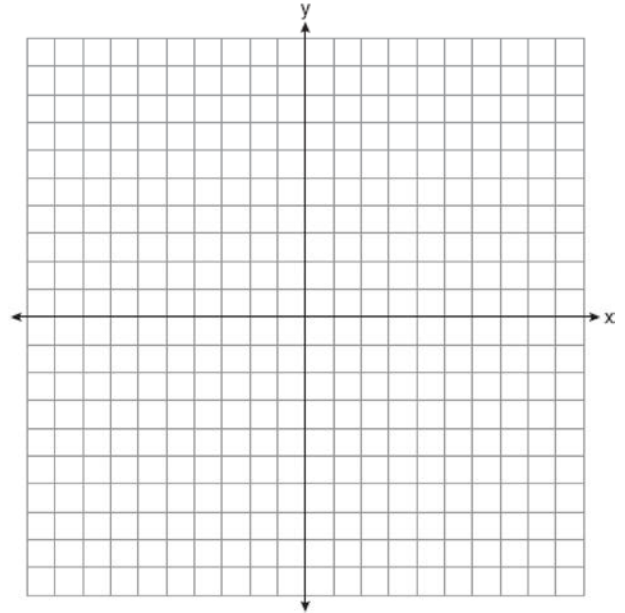

35 In quadrilateral $ABCD$ below, side \overline{CD} is extended through D to point E such that \overline{AFD} and \overline{BFE} bisect each other, and $\overline{DE} \cong \overline{DC}$.

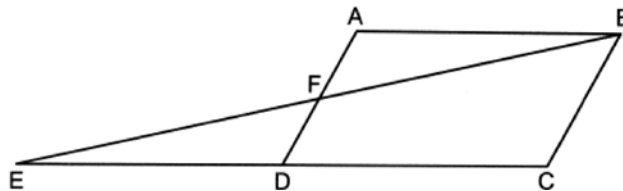

Prove $ABCD$ is a parallelogram.

0126geo

- 1 On the set of axes below, $\triangle RST$ and its image, $\triangle R'S'T'$, are graphed.

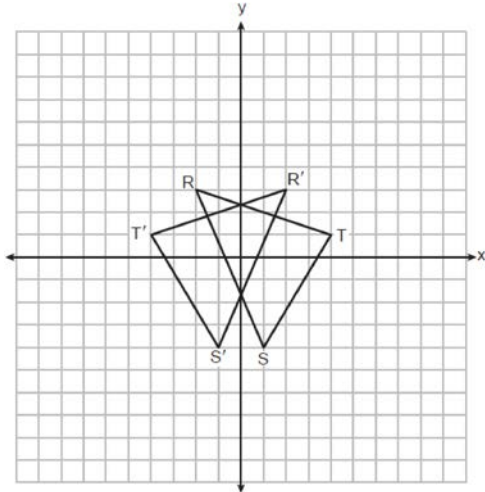

Which rigid motion is sufficient to prove $\triangle RST \cong \triangle R'S'T'$?

- 1) a rotation of 90° clockwise about the origin
 - 2) a translation 4 units to the right
 - 3) a reflection over the x -axis
 - 4) a reflection over the y -axis
- 2 Which regular polygon would carry onto itself after a rotation of 60° about its center?
- 1) pentagon
 - 2) hexagon
 - 3) octagon
 - 4) decagon

- 3 The right triangle below is continuously rotated about the 4 cm side.

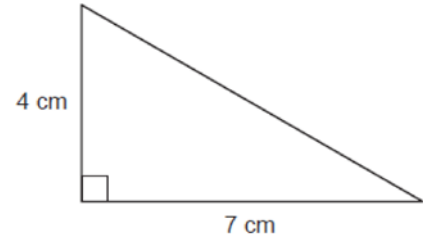

The solid formed is

- 1) a cone with a height of 4 cm and a radius of 7 cm
 - 2) a cone with a height of 4 cm and a radius of 14 cm
 - 3) a pyramid with a height of 4 cm and a base length of 7 cm
 - 4) a pyramid with a height of 4 cm and a base length of 14 cm
- 4 In isosceles triangle AHP below, $\overline{AH} \cong \overline{PH}$, and \overline{AH} is extended through H to C .

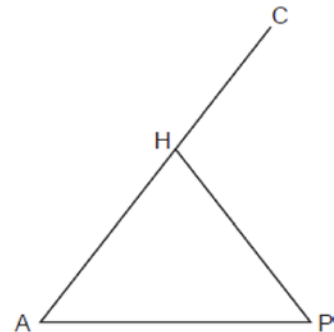

If $m\angle A = (2x + 12)^\circ$ and $m\angle P = (3x - 8)^\circ$, what is the measure of $\angle CHP$?

- 1) 52°
- 2) 76°
- 3) 104°
- 4) 128°

- 5 In the diagram below, $\triangle XYZ$ is the image of $\triangle ABC$ after a dilation of scale factor $\frac{1}{2}$.

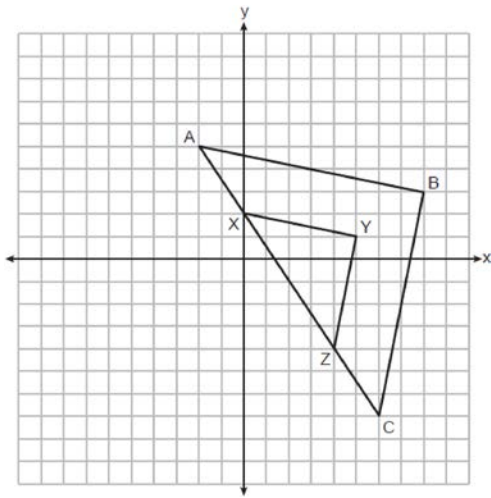

Which point must be the center of dilation?

- 1) $(2, -1)$
 - 2) $(8, 3)$
 - 3) $(5, 1)$
 - 4) $(0, 0)$
- 6 In a right triangle, the acute angles have the relationship $\cos(5x + 7)^\circ = \sin(3x + 3)^\circ$. Which equation is always true?
- 1) $5x + 7 = 3x + 3$
 - 2) $5x + 7 + 3x + 3 = 90$
 - 3) $5x + 7 + 3x + 3 = 180$
 - 4) $5x + 7 + 3x + 3 + x = 180$

- 7 In the diagram below, circle O has a radius of 8 cm and a central angle that measures 140° .

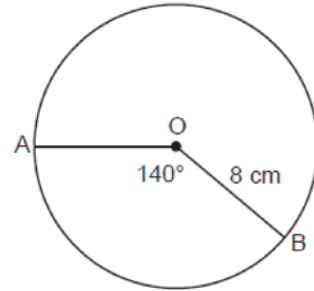

What is the length of \widehat{AB} , to the nearest centimeter?

- 1) 10
 - 2) 20
 - 3) 25
 - 4) 78
- 8 Lucy wants to use a wagon to move a pile of sand in as few trips as possible. The pile of sand can be modeled by a cone, as shown below. The height and radius of the sandpile are both 3.5 feet.

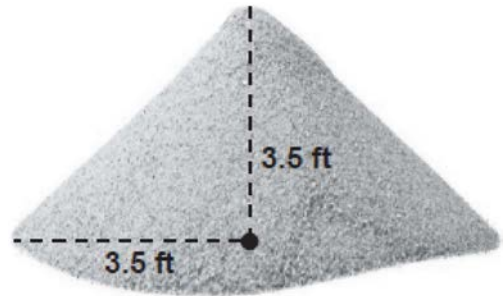

If the wagon holds 5 cubic feet of sand, what is the fewest number of trips Lucy needs to make to move the entire pile of sand?

- 1) 27
- 2) 14
- 3) 3
- 4) 9

- 9 In the diagram below, \overline{BD} and \overline{AE} intersect at C , and \overline{AB} and \overline{DE} are drawn.

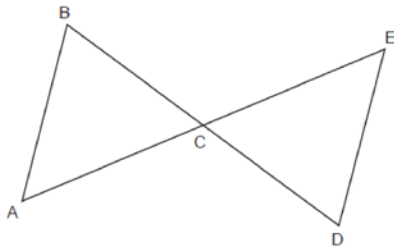

If $\overline{AB} \parallel \overline{DE}$, which statement is *not* always true?

- 1) $\angle ABC \cong \angle EDC$
 - 2) $\angle ACB \cong \angle ECD$
 - 3) $\triangle ABC \sim \triangle EDC$
 - 4) $\triangle ABC \cong \triangle EDC$
- 10 The face of a shed is modeled below. The rectangular section of the face, $BFGK$, is 10 feet wide. The triangular section of the face, FEG , is an isosceles triangle with vertex angle FEG and a height of 6 feet.

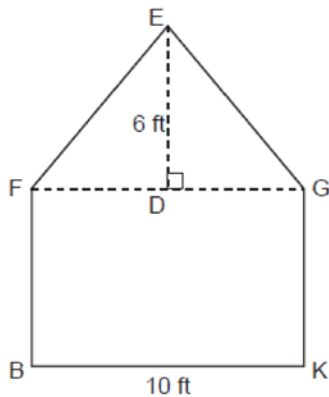

What is $m\angle EGD$, to the nearest degree?

- 1) 34°
- 2) 40°
- 3) 50°
- 4) 56°

- 11 Triangles ABC , $A'B'C'$, and $A''B''C''$ are graphed on the set of axes below.

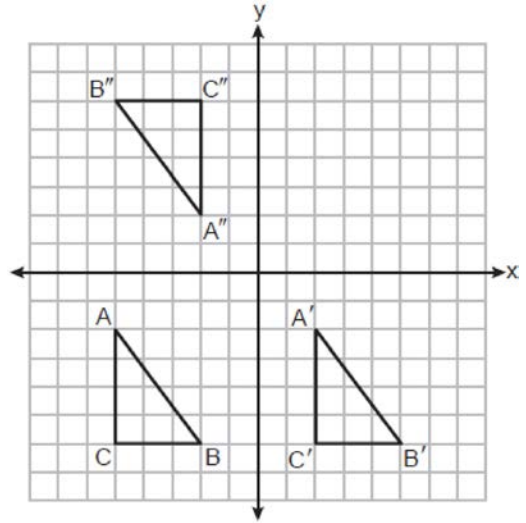

Which sequence of transformations maps $\triangle ABC$ onto $\triangle A'B'C'$, and then maps $\triangle A'B'C'$ onto $\triangle A''B''C''$.

- 1) a translation followed by a rotation
 - 2) a rotation followed by a translation
 - 3) a line reflection followed by a rotation
 - 4) a translation followed by a line reflection
- 12 A line contains the points $(-1, -4)$ and $(3, -1)$. An equation of a line perpendicular to this line is
- 1) $y + 4 = \frac{3}{4}(x + 1)$
 - 2) $y - 4 = \frac{4}{3}(x - 1)$
 - 3) $y - 1 = -\frac{3}{4}(x + 3)$
 - 4) $y + 1 = -\frac{4}{3}(x - 3)$

- 13 In the diagram below of right triangles DAY and NIT , $AD = 6$, $DY = 6$, $IT = 16$, and $\triangle DAY \sim \triangle NIT$.

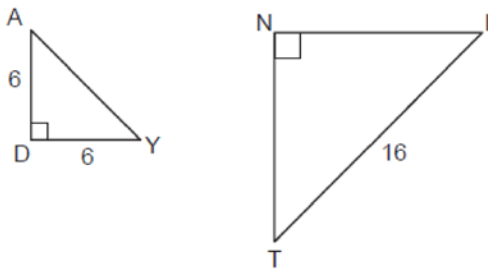

The length of \overline{TN} is

- 1) 8
 - 2) $8\sqrt{2}$
 - 3) $8\sqrt{3}$
 - 4) $16\sqrt{2}$
- 14 The volume of a sphere is 333 cm^3 . To the *nearest tenth of a centimeter*, the diameter of the sphere is
- 1) 4.3
 - 2) 5.2
 - 3) 8.6
 - 4) 10.4
- 15 Line BTS is parallel to line $MAVR$, as shown in the diagram below, and $AE \perp TV$.

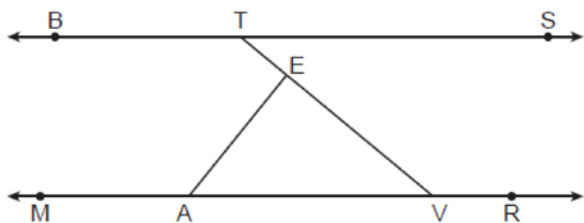

If $m\angle STE = 38^\circ$, what is the measure of $\angle VAE$?

- 1) 38°
- 2) 52°
- 3) 128°
- 4) 142°

- 16 Segment RAZ has endpoints with coordinates $R(6,6)$ and $Z(-12,-3)$. If A divides \overline{RZ} such that $RA:AZ = 5:4$, then the coordinates of A are
- 1) $(-6,0)$
 - 2) $(-2,2)$
 - 3) $(0,3)$
 - 4) $(-4,1)$

- 17 In $\triangle ABC$ below, points D and E are on \overline{AB} and \overline{CB} respectively, such that $\overline{DE} \parallel \overline{AC}$.

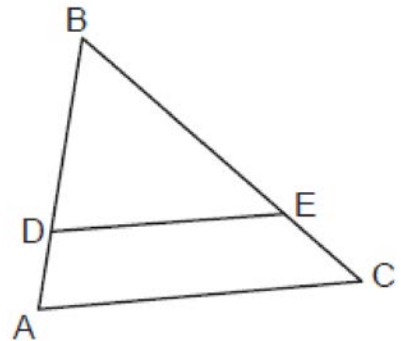

If $BD = 9$, $DA = 3$, and $EC = 4$, what is the length of \overline{BC} ?

- 1) 10
 - 2) 12
 - 3) 14
 - 4) 16
- 18 Triangle ABC is mapped onto $A'B'C'$ after a sequence of rigid motions. Which statement is always true?
- 1) Segment AB is parallel to segment $A'B'$.
 - 2) Segment AB is congruent to segment $A'B'$.
 - 3) The measure of angle A is the same as the measure of angle B' .
 - 4) The orientation of $\triangle ABC$ is the same as the orientation of $\triangle A'B'C'$.

19 What are the coordinates of the center and the length of the radius of the circle whose equation is $x^2 - 16x + y^2 + 20y = -155$?

- 1) center $(8, -10)$ and radius 9
- 2) center $(-8, 10)$ and radius 9
- 3) center $(8, -10)$ and radius 3
- 4) center $(-8, 10)$ and radius 3

20 State populations and land areas from the 2020 US Census are shown in the table below.

| 2020 State Population and Land Area | | |
|-------------------------------------|------------|------------------------------|
| State | Population | Land Area (mi ²) |
| Connecticut | 3,605,944 | 4,842 |
| New Jersey | 9,288,994 | 7,354 |
| New York | 20,201,249 | 47,126 |
| Pennsylvania | 13,002,700 | 44,743 |

Which list shows the state population densities, in order from smallest to largest?

- 1) Pennsylvania, New York, Connecticut,
- 2) Connecticut, New Jersey, Pennsylvania,
- 3) New York, Pennsylvania, New Jersey, Connecticut
- 4) New Jersey, Connecticut, New York, Pennsylvania

21 Line t is represented by the equation $y = 2x - 1$. If the line is dilated by a scale factor of 3 centered at the origin, which equation represents the image of line t after the dilation?

- 1) $y = 2x - 3$
- 2) $y = 6x - 3$
- 3) $y = 2x - 1$
- 4) $y = 6x - 1$

22 Quadrilateral $ABCD$ is a parallelogram. Which additional statement is sufficient to prove $ABCD$ is a rhombus?

- 1) $\overline{AB} \cong \overline{CD}$
- 2) $\overline{AD} \parallel \overline{BC}$
- 3) $\overline{AD} \cong \overline{DC}$
- 4) $\angle ADC \cong \angle ABC$

23 In right triangle ABC below, $m\angle ABC = 90^\circ$, and $\overline{BD} \perp \overline{AC}$.

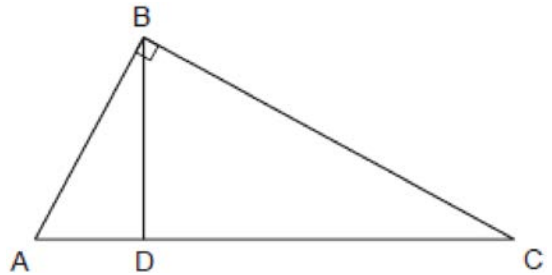

If $AD = 3$ and $CD = 12$, the length of \overline{AB} is

- 1) 6
- 2) 9
- 3) $3\sqrt{5}$
- 4) $5\sqrt{3}$

- 24 In $\triangle GBT$ shown below, \overline{GXM} , \overline{BXR} , and \overline{TXE} are drawn such that point X is the centroid.

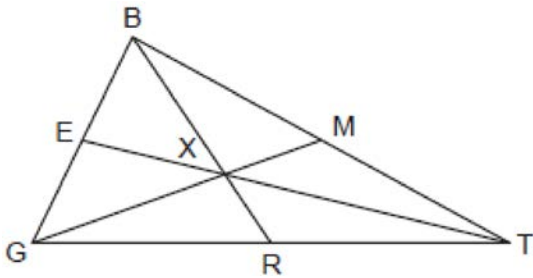

Which statement is always true?

- 1) $\frac{MX}{GX} = \frac{1}{3}$
 - 2) $\frac{TX}{EX} = \frac{2}{1}$
 - 3) $\overline{BX} \cong \overline{RX}$
 - 4) $\overline{TM} \cong \overline{TR}$
- 25 A triangle has vertices with coordinates $(2, 1)$, $(0, 3)$, and $(-2, -1)$. Determine and state the coordinates of the vertices of the image of the triangle after a reflection over the x -axis followed by a translation of 3 units to the right and 2 units down. [The use of the set of axes below is optional.]

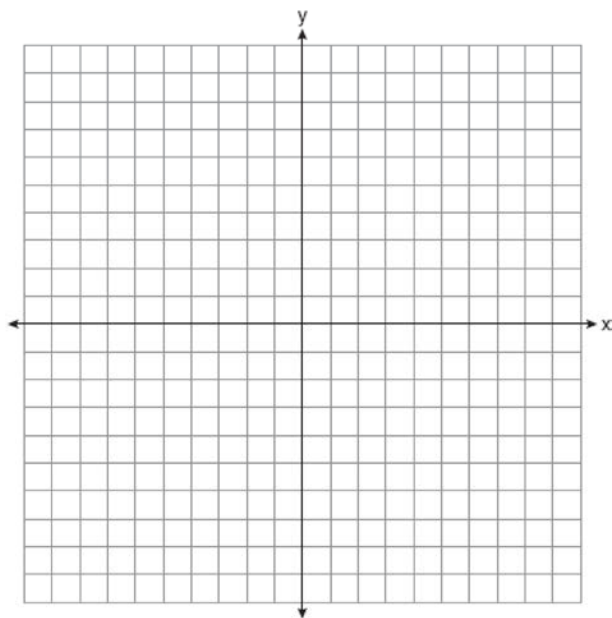

- 26 A cylindrical bucket is being used to transport topsoil. The bucket has an inside diameter of 10 inches and a height of 15 inches. If the topsoil weighs 0.0231 pound per cubic inch, determine and state the weight of the topsoil in the bucket when the bucket is full, to the nearest pound.

- 27 In right triangle SRT , $m\angle R = 90^\circ$, $m\angle S = 27^\circ$, and $ST = 31.8$. Determine and state the length of \overline{SR} , to the nearest tenth.

- 28 In $\triangle LET$ below, $LE = 7.5$, $ET = 9.3$, and $m\angle LET = 115^\circ$.

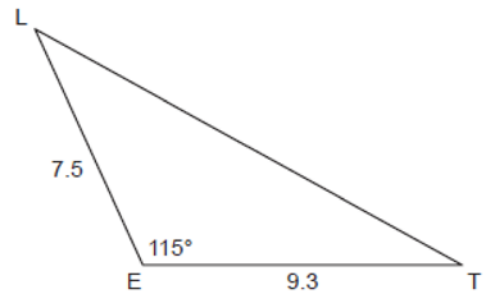

Determine and state the area of $\triangle LET$, to the nearest tenth.

- 29 A pool owner has a circular deck that surrounds her circular pool, as modeled in the diagram below. The pool has a diameter of 24 feet. The distance from the edge of the pool to the outer edge of the deck is 8 feet.

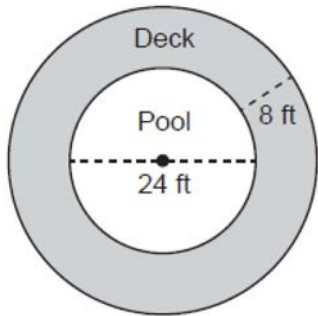

Determine and state the number of square feet of the deck, to the nearest square foot.

- 30 Use a compass and straightedge to construct an equilateral triangle with \overline{AB} , shown below, as one of the sides. [Leave all construction marks.]



- 31 In the diagram below, right triangle ABC is inscribed in the circle with right angle ABC .

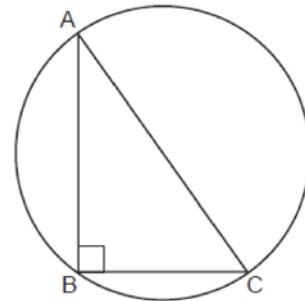

Explain why \overline{AC} must be a diameter of the circle.

- 32 In isosceles triangle ABC below, \overline{AD} is an altitude drawn to base \overline{BC} .

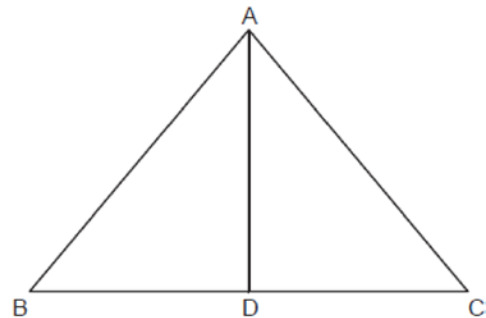

If $m\angle BAC = 80^\circ$ and $AD = 8$, determine and state the perimeter of $\triangle ABC$, to the nearest tenth.

- 33 In quadrilateral $SMIL$ below, diagonals \overline{IS} and \overline{ML} intersect at point E , $\overline{MS} \parallel \overline{IL}$, and $\overline{MS} \cong \overline{IL}$.

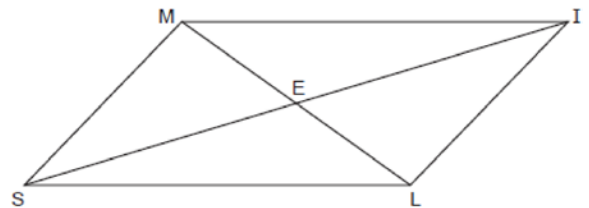

Prove: $\triangle MIE \cong \triangle LSE$

- 34 A solid glass trophy is composed of a rectangular prism and a rectangular pyramid, as modeled below. The rectangular prism has a length of 12 centimeters, a width of 6 centimeters, and a height of 3 centimeters.

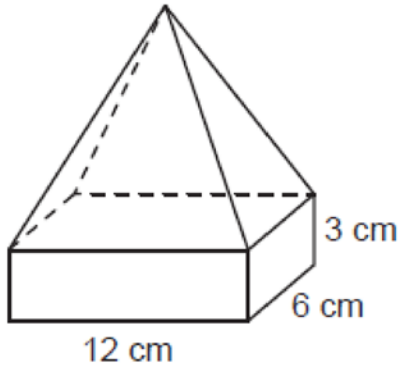

The height of the pyramid is 10 centimeters. If the density of glass is 2.5 grams per cubic centimeter, determine and state the mass of the trophy, in grams.

- 35 Quadrilateral $ABCD$ is graphed on the set of axes below, with vertices at coordinates $A(-3, 1)$, $B(-3, -7)$, $C(6, 5)$, and $D(0, 5)$. Segment EF is graphed with endpoints at coordinates $E(-3, -3)$ and $F(3, 5)$.

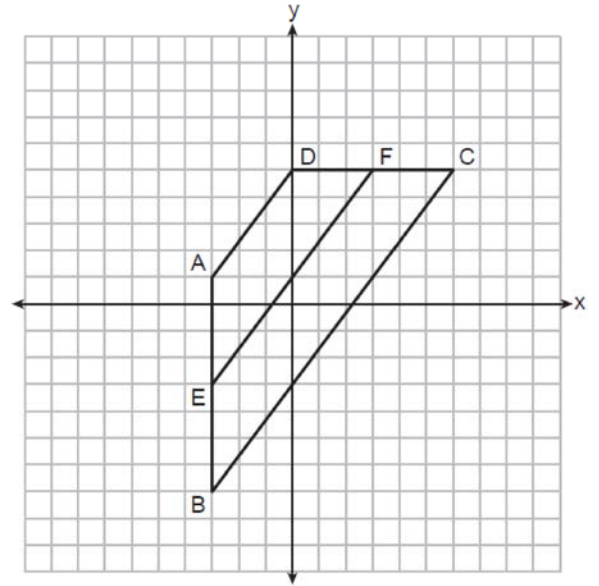

Prove $ABCD$ is a trapezoid. Use coordinate geometry to prove \overline{EF} is parallel to \overline{AD} and \overline{BC} . Is $EF = \frac{1}{2}(AD + BC)$? Use coordinate geometry to justify your answer.

2024 Geometry Sample Items

Answer Section

1 ANS: 2 PTS: 2 REF: spr2401geo NAT: G.CO.A.2
TOP: Identifying Transformations

2 ANS: 3

$$\frac{6\sqrt{3}}{x} = \frac{\sqrt{3}}{2}$$

$$x = 12$$

PTS: 2 REF: spr2402geo NAT: G.SRT.C.8 TOP: Special Right Triangles
3 ANS: 2

$$K = \frac{1}{2}(8)(5)\sin 57 \approx 16.8$$

PTS: 2 REF: spr2403geo NAT: G.SRT.D.9 TOP: Using Trigonometry to Find Area
KEY: basic

4 ANS: 4 PTS: 2 REF: spr2404geo NAT: G.GPE.A.1
TOP: Equations of Circles KEY: write equation, given graph

5 ANS:

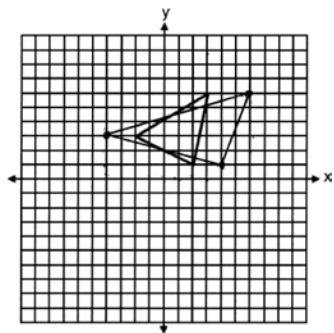

PTS: 2 REF: spr2405geo NAT: G.CO.A.2
TOP: Analytical Representations of Transformations KEY: graphics

6 ANS:



PTS: 2 REF: spr2406geo NAT: G.CO.D.12 TOP: Constructions
 KEY: line bisector

7 ANS:

$$\frac{4}{x+3} = \frac{x-1}{15} \quad 7+3 = 10$$

$$x^2 - x + 3x - 3 = 60$$

$$x^2 + 2x - 63 = 0$$

$$(x+9)(x-7) = 0$$

$$x = 7$$

PTS: 4 REF: spr2407geo NAT: G.SRT.B.5 TOP: Similarity
 KEY: basic

8 ANS:

$$4\sqrt{3^2 + 3^2} + 2(2) = 4\sqrt{18} + 4 = 12\sqrt{2} + 4$$

PTS: 2 REF: spr2408geo NAT: G.GPE.B.7 TOP: Polygons in the Coordinate Plane

0625geo

Answer Section

- 1 ANS: 3 PTS: 2 REF: 062501geo NAT: G.SRT.A.2
TOP: Dilations
- 2 ANS: 3
 $\tan 70.19 = \frac{h}{200}$
 $h \approx 555$
- PTS: 2 REF: 062502geo NAT: G.SRT.C.8 TOP: Using Trigonometry to Find a Side
- 3 ANS: 1 PTS: 2 REF: 062503geo NAT: G.CO.A.5
TOP: Compositions of Transformations
- 4 ANS: 2
 $2 + 7 > 8$
- PTS: 2 REF: 062504geo NAT: G.CO.C.10 TOP: Triangle Inequality Theorem
- 5 ANS: 2
 $\frac{360^\circ}{8} = 45^\circ$ 90° is a multiple of 45°
- PTS: 2 REF: 062505geo NAT: G.CO.A.3 TOP: Mapping a Polygon onto Itself
- 6 ANS: 4
 $x^2 - 6x + 9 + y^2 + 2y + 1 = 14 + 9 + 1$
 $(x - 3)^2 + (y + 1)^2 = 24$
- PTS: 2 REF: 062506geo NAT: G.GPE.A.1 TOP: Equations of Circles
KEY: completing the square
- 7 ANS: 3
 $\cos F = \frac{23}{30}$
 $F \approx 40^\circ$
- PTS: 2 REF: 062507geo NAT: G.SRT.C.8 TOP: Using Trigonometry to Find an Angle
- 8 ANS: 2
 $\frac{14}{2} + 9 + \frac{14}{2} + 9 = 32$
- PTS: 2 REF: 062508geo NAT: G.CO.C.10 TOP: Midsegments
- 9 ANS: 3
 $\frac{\frac{1}{3}(6^2)(10)}{3.5} \approx 34.3$
- PTS: 2 REF: 062509geo NAT: G.GMD.A.3 TOP: Volume
KEY: pyramids

10 ANS: 3

$$\frac{\frac{360-68}{2} - 68}{2} = 39$$

PTS: 2 REF: 062510geo NAT: G.C.A.2 TOP: Chords, Secants and Tangents
 KEY: secant and tangent drawn from common point, angle

11 ANS: 1

$$\frac{1}{2} (7)(12) \sin(33) \approx 22.9$$

PTS: 2 REF: 062511geo NAT: G.SRT.D.9 TOP: Using Trigonometry to Find Area
 KEY: basic

12 ANS: 4

TOP: Identifying Transformations

PTS: 2

REF: 062512geo

NAT: G.CO.A.2

13 ANS: 1

$$m = 4$$

PTS: 2 REF: 062513geo NAT: G.GPE.B.5 TOP: Parallel and Perpendicular Lines
 KEY: write equation of parallel line

14 ANS: 4

TOP: Cross-Sections of Three-Dimensional Objects

PTS: 2

REF: 062514geo

NAT: G.GMD.B.4

15 ANS: 2

$$\frac{8}{12} = \frac{11}{x}$$

$$8x = 132$$

$$x = 16.5$$

PTS: 2 REF: 062515geo NAT: G.SRT.B.4 TOP: Side Splitter Theorem

16 ANS: 4

TOP: Special Quadrilaterals

PTS: 2

REF: 062516geo

NAT: G.CO.C.11

17 ANS: 4

$$-2 + \frac{1}{5} (3 - -2) = -2 + \frac{1}{5} (5) = -2 + 1 = -1 \quad -9 + \frac{1}{5} (6 - -9) = -9 + \frac{1}{5} (15) = -9 + 3 = -6$$

PTS: 2 REF: 062517geo NAT: G.GPE.B.6 TOP: Directed Line Segments

18 ANS: 1

$$\frac{4}{3} \pi \left(\frac{1.7}{2} \right)^3 \times .8 \approx 2.06$$

PTS: 2 REF: 062518geo NAT: G.GMD.A.3 TOP: Volume
 KEY: spheres

19 ANS: 3

$$x^2 = 2.5 \times (2.5 + 4.3)$$

$$x \approx 4.1$$

PTS: 2 REF: 062519geo NAT: G.SRT.B.4 TOP: Similarity

20 ANS: 1

$$180 - 141 = 39$$

PTS: 2 REF: 062520geo NAT: G.CO.C.11 TOP: Trapezoids

21 ANS: 2

PTS: 2 TOP: Properties of Transformations

REF: 062521geo NAT: G.CO.B.6

22 ANS: 2

PTS: 2 TOP: Identifying Transformations

REF: 062522geo NAT: G.CO.A.2

23 ANS: 4

$$75.4 = \frac{1}{3} \pi r^2 (8)$$

$$r \approx 3$$

PTS: 2 REF: 062523geo NAT: G.GMD.A.3 TOP: Volume

KEY: cones

24 ANS: 1

$$5(2) - 2(0) = 10$$

PTS: 2 REF: 062524geo NAT: G.SRT.A.1 TOP: Line Dilations

25 ANS:

$$\text{Lancaster } \frac{10087}{2.7} > \frac{15069}{5.1}$$

PTS: 2 REF: 062525geo NAT: G.MG.A.2 TOP: Density

26 ANS:

$$3x - 22 + 4x - 18 = 6x - 23 \quad 180 - (6(17) - 23) = 180 - (102 - 23) = 180 - 79 = 101$$

$$7x - 40 = 6x - 23$$

$$x = 17$$

PTS: 2 REF: 062526geo NAT: G.CO.C.10 TOP: Exterior Angle Theorem

27 ANS:

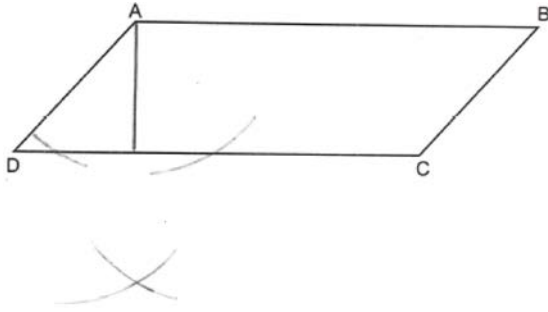

PTS: 2 REF: 062527geo NAT: G.CO.D.12 TOP: Constructions

KEY: parallel and perpendicular lines

28 ANS:

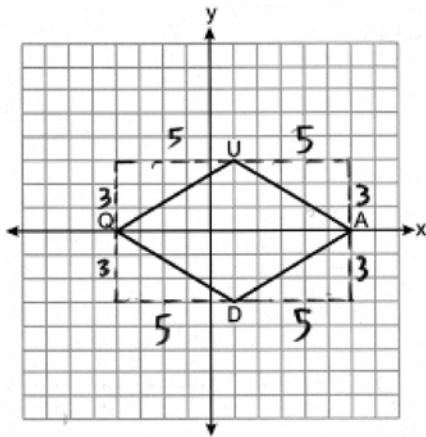

$$(10 \times 6) - 4 \left(\frac{1}{2} (5)(3) \right) = 60 - 30 = 30$$

PTS: 2 REF: 062528geo NAT: G.GPE.B.7 TOP: Polygons in the Coordinate Plane

29 ANS:

$$3x - 7 + x + 1 = 90$$

$$4x - 6 = 90$$

$$4x = 96$$

$$x = 24$$

PTS: 2 REF: 062529geo NAT: G.SRT.C.7 TOP: Cofunctions

30 ANS:

$$40\pi \left(\frac{36}{360} \right) = 4\pi$$

PTS: 2 REF: 062530geo NAT: G.C.B.5 TOP: Arc Length

31 ANS:

$$\frac{5.6}{6} = \frac{8.4}{9} \rightarrow 50.4 = 50.4 \quad \frac{4}{6} = \frac{6}{9} \rightarrow 36 = 36 \quad \frac{4}{5.6} = \frac{6}{8.4} \rightarrow 33.6 = 33.6$$

The corresponding sides are proportional.

PTS: 2 REF: 062531geo NAT: G.SRT.B.5 TOP: Similarity

KEY: basic

32 ANS:

The cone: 1) $4 \times 4 \times 7.5 = 120$; 2) $\pi(2.5)^2(6) \approx 118$; 3) $\frac{1}{3} \pi(3.75)^2(8.5) \approx 125$

PTS: 4 REF: 062532geo NAT: G.GMD.A.3 TOP: Volume

KEY: cones

33 ANS:

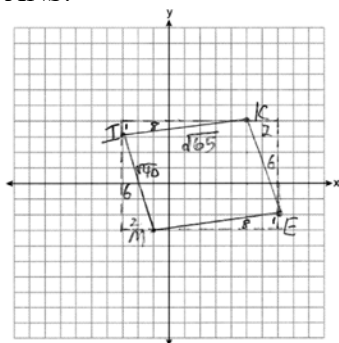

$$m_{\overline{MI}} = \frac{-3 - (-1)}{-1 - (-1)} = \frac{-6}{2} = -3; \quad m_{\overline{KE}} = \frac{4 - (-2)}{5 - 7} = \frac{6}{-2} = -3; \quad m_{\overline{IK}} = \frac{4 - (-3)}{5 - (-1)} = \frac{7}{6}$$

$$m_{\overline{ME}} = \frac{-2 - (-3)}{7 - (-1)} = \frac{1}{8}$$

Because opposite side of Quadrilateral *MIKE* have the same slope, the sides are parallel.

The opposite sides of a parallelogram are parallel, so *MIKE* is a parallelogram. $MI = \sqrt{6^2 + 2^2} = \sqrt{40}$;

$IK = \sqrt{8^2 + 1^2} = \sqrt{65}$. Because two sides of Quadrilateral *MIKE* have different lengths, they are not congruent.

All the sides of a rhombus are congruent, so *MIKE* is not a rhombus.

PTS: 4 REF: 062533geo NAT: G.GPE.B.4 TOP: Quadrilaterals in the Coordinate Plane

34 ANS:

$$\sin 24 = \frac{4}{x} \quad \sin 11.6 = \frac{3}{y} \quad \text{No, because } 9.8 + 14.9 > 20.$$

$$x \approx 9.8 \quad y \approx 14.9$$

PTS: 4 REF: 062534geo NAT: G.SRT.C.8 TOP: Using Trigonometry to Find a Side

35 ANS:

1) Quadrilateral *CARI* with $\overline{CA} \cong \overline{RI}$ and $\overline{CI} \cong \overline{RA}$, and \overline{AEI} and \overline{LEH} are drawn (Given); 2) Quadrilateral *CARI* is a parallelogram (Opposite sides of a parallelogram are congruent); 3) $\overline{CA} \parallel \overline{RI}$ and $\overline{CI} \parallel \overline{RA}$ (Opposite sides of a parallelogram are parallel); 4) $\angle AHE \cong \angle ILE$ and $\angle HAE \cong \angle LIE$ (Parallel lines cut by a transversal create congruent alternate interior angles); 5) $\triangle HAE \sim \triangle LIE$ (AA); 6) $\frac{HA}{EH} = \frac{LI}{EL}$ (Corresponding sides of similar triangles are proportional); 7) $HA \cdot EL = LI \cdot EH$ (The product of the means equals the product of the extremes).

PTS: 6 REF: 062535geo NAT: G.SRT.B.5 TOP: Quadrilateral Proofs

0825geo

Answer Section

1 ANS: 1 PTS: 2 REF: 082501geo NAT: G.GMD.B.4
TOP: Rotations of Two-Dimensional Objects

2 ANS: 3 PTS: 2 REF: 082502geo NAT: G.CO.B.6
TOP: Properties of Transformations

3 ANS: 2

$$\cos 38 = \frac{x}{31.8}$$

$$x \approx 25.1$$

PTS: 2 REF: 082503geo NAT: G.SRT.C.8 TOP: Using Trigonometry to Find a Side

4 ANS: 3

$$V = \frac{1}{2} \times \frac{4}{3} \pi \cdot (8)^3 \approx 1072$$

PTS: 2 REF: 082504geo NAT: G.GMD.A.3 TOP: Volume

KEY: spheres

5 ANS: 4 PTS: 2 REF: 082505geo NAT: G.CO.C.11

TOP: Special Quadrilaterals

6 ANS: 4

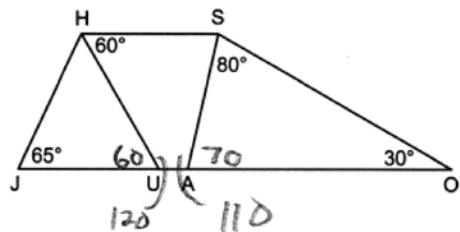

PTS: 2 REF: 082506geo NAT: G.CO.C.11 TOP: Interior and Exterior Angles of Polygons

7 ANS: 2

$$\frac{4}{6} = \frac{12}{x}$$

$$4x = 72$$

$$x = 18$$

PTS: 2 REF: 082507geo NAT: G.SRT.B.4 TOP: Side Splitter Theorem

8 ANS: 1 PTS: 2 REF: 082508geo NAT: G.GPE.A.1

TOP: Equations of Circles

KEY: write equation, given graph

9 ANS: 3 PTS: 2 REF: 082509geo NAT: G.CO.A.2

TOP: Identifying Transformations

KEY: graphics

10 ANS: 3

$$17x = 22 \cdot 10$$

$$x \approx 12.9$$

PTS: 2 REF: 082510geo NAT: G.C.A.2 TOP: Chords, Secants and Tangents

KEY: secants drawn from common point, length

11 ANS: 4 PTS: 2 REF: 082511geo NAT: G.CO.C.10

TOP: Interior and Exterior Angles of Triangles

12 ANS: 3

The slope of line h is $\frac{2}{3}$. The perpendicular slope is $-\frac{3}{2}$.

PTS: 2 REF: 082512geo NAT: G.GPE.B.5 TOP: Parallel and Perpendicular Lines

KEY: write equation of perpendicular line

13 ANS: 1

$$\frac{1}{3}(8.2)^2(17.4)(0.77) \approx 300$$

PTS: 2 REF: 082513geo NAT: G.MG.A.2 TOP: Density

14 ANS: 2

$$3x - 5 = 2(x + 3)$$

$$3x - 5 = 2x + 6$$

$$x = 11$$

PTS: 2 REF: 082514geo NAT: G.CO.C.10 TOP: Midsegments

15 ANS: 3

$$x^2 + x^2 = (10\sqrt{2})^2$$

$$2x^2 = 200$$

$$x^2 = 100$$

$$x = 10$$

PTS: 2 REF: 082515geo NAT: G.SRT.C.8 TOP: Special Right Triangles

16 ANS: 3

$$K = \frac{1}{2}(8)(9)\sin 55 \approx 29$$

PTS: 2 REF: 082516geo NAT: G.SRT.D.9 TOP: Using Trigonometry to Find Area

KEY: basic

17 ANS: 2

$$x_0 = \frac{kx_1 - x_2}{k - 1} = \frac{2(3) - 4}{2 - 1} = 2 \quad y_0 = \frac{ky_1 - y_2}{k - 1} = \frac{2(3) - 5}{2 - 1} = 1$$

PTS: 2 REF: 082517geo NAT: G.SRT.A.2 TOP: Dilations

18 ANS: 4

$$4 + 8 + \sqrt{4^2 + 8^2} = 12 + \sqrt{80} = 12 + 4\sqrt{5}$$

PTS: 2 REF: 082518geo NAT: G.GPE.B.7 TOP: Polygons in the Coordinate Plane

19 ANS: 4 PTS: 2 REF: 082519geo NAT: G.SRT.B.5

TOP: Similarity KEY: basic

20 ANS: 2

$$\frac{10 \cdot 4 \cdot \frac{1}{3}}{0.6} \approx 22.2$$

PTS: 2 REF: 082520geo NAT: G.GMD.A.3 TOP: Volume

KEY: prisms

21 ANS: 1

$$4x - 6y = 24$$

$$-6y = -4x + 24$$

$$y = \frac{2}{3}x - 4$$

PTS: 2 REF: 082521geo NAT: G.SRT.A.1 TOP: Line Dilations

22 ANS: 1 PTS: 2 REF: 082522geo NAT: G.CO.A.3

TOP: Mapping a Polygon onto Itself

23 ANS: 2

$$\frac{x}{20} = \frac{15}{25}$$

$$25x = 300$$

$$x = 12$$

PTS: 2 REF: 082523geo NAT: G.SRT.B.4 TOP: Similarity

24 ANS: 1

$$\left(\frac{\sqrt{36}}{2} \right)^2 = 9$$

PTS: 2 REF: 082524geo NAT: G.SRT.B.5 TOP: Similarity

KEY: perimeter and area

25 ANS:

Translations preserve distance.

PTS: 2 REF: 082525geo NAT: G.CO.B.6 TOP: Properties of Transformations

26 ANS:

$$\frac{982.5}{5^3} = 7.86 \text{ Iron}$$

PTS: 2 REF: 082526geo NAT: G.MG.A.2 TOP: Density

27 ANS:

$$-3 + \frac{3}{5}(7 - -3) = -3 + \frac{3}{5}(10) = -3 + 6 = 3 \quad 1 + \frac{3}{5}(6 - 1) = 1 + \frac{3}{5}(5) = 1 + 3 = 4 \quad (3, 4)$$

PTS: 2

REF: 082527geo

NAT: G.GPE.B.6

TOP: Directed Line Segments

28 ANS:

$$\sin 4.8 = \frac{.6}{x}$$

$$x \approx 7.2$$

PTS: 2

REF: 082528geo

NAT: G.SRT.C.8

TOP: Using Trigonometry to Find a Side

29 ANS:

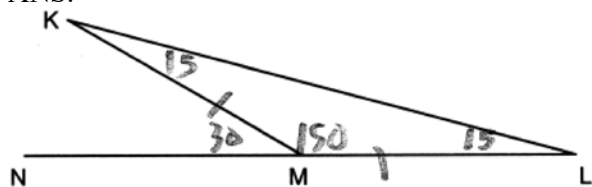

PTS: 2

REF: 082529geo

NAT: G.CO.C.10

TOP: Exterior Angle Theorem

30 ANS:

$$\frac{7.5\pi}{25\pi} \cdot 360 = 108$$

PTS: 2

REF: 082530geo

NAT: G.C.B.5

TOP: Sectors

31 ANS:



PTS: 2

REF: 082531geo

NAT: G.CO.D.12

TOP: Constructions

KEY: line bisector

32 ANS:

$$\frac{75000}{\pi(10)^2(26)} \approx 9$$

PTS: 4

REF: 082532geo

NAT: G.GMD.A.3

TOP: Volume

KEY: cylinders

33 ANS:

$$\tan 50 = \frac{12}{x} \quad 10 + 3 = 13 \quad \tan \theta = \frac{12}{13}$$

$$x \approx 10 \quad \theta \approx 43$$

PTS: 4

REF: 082533geo

NAT: G.SRT.C.8

TOP: Using Trigonometry to Find an Angle

34 ANS:

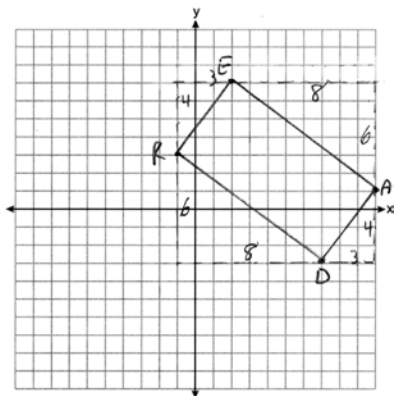

$$m_{\overline{RE}} = \frac{4}{3} \quad m_{\overline{EA}} = -\frac{6}{8} = -\frac{3}{4} \quad m_{\overline{AD}} = \frac{4}{3} \quad m_{\overline{DR}} = -\frac{6}{8} = -\frac{3}{4}$$

Adjacent sides have

slopes that are opposite reciprocals, so are perpendicular. Perpendicular lines form right angles. A quadrilateral with four right angles is a rectangle.

PTS: 4

REF: 082534geo

NAT: G.GPE.B.4

TOP: Quadrilaterals in the Coordinate Plane

35 ANS:

1) Quadrilateral $ABCD$, side \overline{CD} is extended through D to point E such that \overline{AFD} and \overline{BFE} bisect each other, and $\overline{DE} \cong \overline{DC}$ (given); 2) $\overline{FE} \cong \overline{FB}$ and $\overline{FD} \cong \overline{FA}$ (bisected lines form two congruent segments); 3) $\angle EFD \cong \angle BFA$ (vertical angles are congruent); 4) $\triangle EFD \cong \triangle BFA$ (SAS); 5) $\overline{AB} \cong \overline{DE}$, $\angle E \cong \angle ABF$ (CPCTC); 6) $\overline{AB} \cong \overline{DC}$ (Substitution); 7) $\overline{AB} \parallel \overline{DC}$ (if the alternate interior angles formed by a transversal crossing two lines are congruent, the lines are parallel); 8) $ABCD$ is a parallelogram (if a pair of opposite sides of a quadrilateral are parallel and congruent, it is a parallelogram).

PTS: 6

REF: 082535geo

NAT: G.SRT.B.5

TOP: Quadrilateral Proofs

0126geo

Answer Section

1 ANS: 4 PTS: 2 REF: 012601geo NAT: G.CO.A.2
TOP: Identifying Transformations

2 ANS: 2
 $\frac{360}{6} = 60$

PTS: 2 REF: 012602geo NAT: G.CO.A.3 TOP: Mapping a Polygon onto Itself

3 ANS: 1 PTS: 2 REF: 012603geo NAT: G.GMD.B.4
TOP: Rotations of Two-Dimensional Objects

4 ANS: 3
 $2x + 12 = 3x - 8 \quad m\angle A = m\angle P = 2(20) + 12 = 3(20) - 8 = 52$
 $20 = x$

PTS: 2 REF: 012604geo NAT: G.CO.C.10 TOP: Exterior Angle Theorem

5 ANS: 1

$$x_0 = \frac{kx_1 - x_2}{k - 1} = \frac{\frac{1}{2}(-2) - 0}{\frac{1}{2} - 1} = \frac{-1}{-\frac{1}{2}} = 2 \quad y_0 = \frac{ky_1 - y_2}{k - 1} = \frac{\frac{1}{2}(5) - 2}{\frac{1}{2} - 1} = \frac{\frac{1}{2}}{-\frac{1}{2}} = -1$$

PTS: 2 REF: 012605geo NAT: G.SRT.A.2 TOP: Dilations

6 ANS: 2
Sine and cosine are cofunctions.

PTS: 2 REF: 012606geo NAT: G.SRT.C.7 TOP: Cofunctions

7 ANS: 2
 $\frac{140}{360} \cdot 16\pi \approx 20$

PTS: 2 REF: 012607geo NAT: G.C.B.5 TOP: Arc Length

8 ANS: 4
 $\frac{\frac{1}{3}\pi(3.5)^2(3.5)}{5} \approx 9$

PTS: 2 REF: 012608geo NAT: G.GMD.A.3 TOP: Volume
KEY: cones

9 ANS: 4

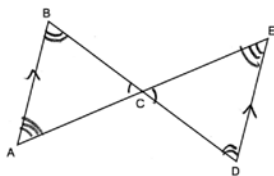

PTS: 2 REF: 012609geo NAT: G.SRT.B.5 TOP: Triangle Proofs
 KEY: statements

10 ANS: 3

$$\tan x = \frac{6}{5}$$

$$x \approx 50^\circ$$

PTS: 2 REF: 012610geo NAT: G.SRT.C.8 TOP: Using Trigonometry to Find an Angle

11 ANS: 1 PTS: 2 REF: 012611geo NAT: G.CO.A.5

TOP: Compositions of Transformations

12 ANS: 4

$$m = \frac{-4 - (-1)}{-1 - 3} = \frac{-3}{-4} = \frac{3}{4}$$

$$m_{\perp} = -\frac{4}{3}$$

PTS: 2 REF: 012612geo NAT: G.GPE.B.5 TOP: Parallel and Perpendicular Lines

KEY: write equation of perpendicular line

13 ANS: 2

$$\frac{16}{x} = \frac{\sqrt{6^2 + 6^2}}{6}$$

$$\sqrt{72}x = 96$$

$$6\sqrt{2}x = 96$$

$$x = \frac{96}{6\sqrt{2}} = \frac{16}{\sqrt{2}} \cdot \frac{\sqrt{2}}{\sqrt{2}} = 8\sqrt{2}$$

PTS: 2 REF: 012613geo NAT: G.SRT.B.5 TOP: Similarity

KEY: basic

14 ANS: 3

$$333 = \frac{4}{3}\pi r^3$$

$$4.3 \approx r$$

$$8.6 \approx r$$

PTS: 2 REF: 012614geo NAT: G.GMD.A.3 TOP: Volume

KEY: spheres

15 ANS: 2

$$180 - (90 + 38) = 180 - 128 = 52$$

PTS: 2 REF: 012615geo NAT: G.CO.C.9 TOP: Lines and Angles

16 ANS: 4

$$6 + \frac{5}{9}(-12 - 6) = 6 + \frac{5}{9}(-18) = 6 - 10 = -4 \quad 6 + \frac{5}{9}(-3 - 6) = 6 + \frac{5}{9}(-9) = 6 - 5 = 1$$

PTS: 2 REF: 012616geo NAT: G.GPE.B.6 TOP: Directed Line Segments

17 ANS: 4

$$\frac{x}{9} = \frac{x+4}{12}$$

$$12x = 9x + 36$$

$$3x = 36$$

$$x = 12$$

PTS: 2 REF: 012617geo NAT: G.SRT.B.4 TOP: Side Splitter Theorem

18 ANS: 2 PTS: 2 REF: 012618geo NAT: G.CO.B.6

TOP: Properties of Transformations

19 ANS: 3

$$x^2 - 16x + 64 + y^2 + 20y + 100 = -155 + 64 + 100$$

$$(x - 8)^2 + (y + 10)^2 = 9$$

PTS: 2 REF: 012619geo NAT: G.GPE.A.1 TOP: Equations of Circles

KEY: completing the square

20 ANS: 1

$$\text{Pennsylvania: } \frac{13002700}{44743} \approx 291 \quad \text{New York: } \frac{20201249}{47126} \approx 429, \quad \text{Connecticut: } \frac{3605944}{4842} \approx 745, \quad \text{New Jersey:}$$

$$\frac{9288994}{7354} \approx 1263$$

PTS: 2 REF: 012620geo NAT: G.MG.A.2 TOP: Density

21 ANS: 1 PTS: 2 REF: 012621geo NAT: G.SRT.A.1

TOP: Line Dilations

22 ANS: 3 PTS: 2 REF: 012622geo NAT: G.CO.C.11

TOP: Special Quadrilaterals

23 ANS: 3

$$x^2 = 3(3 + 12)$$

$$x = \sqrt{45} = 3\sqrt{5}$$

PTS: 2 REF: 012623geo NAT: G.SRT.B.4 TOP: Similarity

24 ANS: 2

A centroid cuts each median 2:1.

PTS: 2 REF: 012624geo NAT: G.SRT.B.4

TOP: Centroid, Orthocenter, Incenter and Circumcenter

25 ANS:

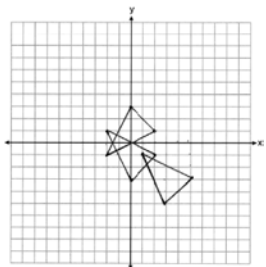
 $(2, 1), (0, 3), (-2, -1) \rightarrow (2, -1), (0, -3), (-2, 1) \rightarrow (5, -3), (3, -5), (1, -1)$

PTS: 2 REF: 012625geo NAT: G.CO.A.5 TOP: Compositions of Transformations

26 ANS:

$$\pi \left(\frac{10}{2} \right)^2 (15)(0.0231) \approx 27$$

PTS: 2 REF: 012626geo NAT: G.MG.A.2 TOP: Density

27 ANS:

$$\cos 27 = \frac{x}{31.8}$$

$$x \approx 28.3$$

PTS: 2 REF: 012627geo NAT: G.SRT.C.8 TOP: Using Trigonometry to Find a Side

28 ANS:

$$\frac{1}{2} \cdot 7.5 \cdot 9.3 \sin 115 \approx 31.6$$

PTS: 2 REF: 012628geo NAT: G.SRT.D.9 TOP: Using Trigonometry to Find Area

29 ANS:

$$20^2 \pi - 12^2 \pi \approx 804$$

PTS: 2 REF: 012629geo NAT: G.MG.A.3 TOP: Compositions of Polygons and Circles

KEY: area

30 ANS:

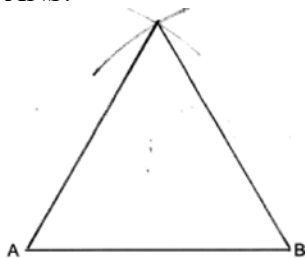

PTS: 2 REF: 012630geo NAT: G.CO.D.12 TOP: Constructions
KEY: polygons

31 ANS:

Since $\angle B$ is a right angle, \widehat{AC} is subtended by $\angle B$ and measures 180° . A diameter has a measure of 180° .

PTS: 2 REF: 012631geo NAT: G.C.A.2 TOP: Chords, Secants and Tangents
KEY: inscribed

32 ANS:

$$BD = DC \quad AB = BC = \sqrt{8^2 + 6.713^2} \approx 10.4434 \quad 2(6.713) + 2(10.4434) \approx 34.3$$

$$\tan 40 = \frac{x}{8}$$

$$x \approx 6.713$$

PTS: 2 REF: 012632geo NAT: G.SRT.C.8 TOP: Using Trigonometry to Find a Side

33 ANS:

Quadrilateral $SMIL$, diagonals \overline{IS} and \overline{ML} intersect at point E , $\overline{MS} \parallel \overline{IL}$, and $\overline{MS} \cong \overline{IL}$ (given); $SMIL$ is a parallelogram (A quadrilateral with parallel and congruent opposite sides is a parallelogram); $\overline{MI} \parallel \overline{LS}$ and $\overline{MI} \cong \overline{LS}$ (Opposite sides of a parallelogram are parallel and congruent); $\angle IMS \cong \angle SLE$ (Alternative interior angles formed by a transversal and parallel lines are congruent); $\angle MEI \cong \angle LES$ (Vertical angles are congruent); $\triangle MIE \cong \triangle LSE$ (AAS)

PTS: 4 REF: 012633geo NAT: G.SRT.B.5 TOP: Quadrilateral Proofs

34 ANS:

$$\left((12)(6)(3) + \frac{1}{3} (12)(6)(10) \right) \times 2.5 = 1140$$

PTS: 4 REF: 012634geo NAT: G.MG.A.2 TOP: Density

35 ANS:

$m_{\overline{AD}} = \frac{5-1}{0--3} = \frac{4}{3}$ $m_{\overline{BC}} = \frac{5--7}{6--3} = \frac{12}{9} = \frac{4}{3}$ Since quadrilateral $ABCD$ has a pair of parallel opposite sides, it is a trapezoid. $m_{\overline{EF}} = \frac{5--3}{3--3} = \frac{8}{6} = \frac{4}{3}$ Since \overline{EF} , \overline{AD} and \overline{BC} have the same slope, they are parallel.

$$EF = \sqrt{(-3-3)^2 + (-3-5)^2} = \sqrt{36+64} = 10, AD = \sqrt{(-3-0)^2 + (1-5)^2} = \sqrt{9+16} = 5,$$

$$BC = \sqrt{(6--3)^2 + (5--7)^2} = \sqrt{81+144} = 15, 10 = \frac{1}{2}(5+15)$$

PTS: 6

REF: 012635geo

NAT: G.GPE.B.4

TOP: Quadrilaterals in the Coordinate Plane